

Happy collecting,

Jack H. Ford

A History of the

ELECTRICAL PORCELAIN

Industry in the United States

By Jack H. Tod

Published privately by
Jack H. Tod
3427 N. 47th Place
Phoenix, AZ 85018



Copyright © 1977 by Jack H. Tod

All rights reserved. This book or any part thereof
may not be reproduced in any form without the
written permission of the author.

Library of Congress Catalog Card No. 77-087772

Printed in U.S.A.

ACKNOWLEDGEMENTS

A substantial portion of this book was made possible through the aid and cooperation of a number of the porcelain insulator manufacturers who gave the author detailed tours of all the manufacturing operations, furnished considerable old insulator catalogs and other data from their files and allowed detailed inspection and study of the plant dumpage. It isn't possible to mention the countless individuals giving assistance, but deep appreciation is expressed to the following companies for their particular contributions:

A. B. Chance Co., Parkersburg, W. Va.
Knox Porcelain Corp., Knoxville, Tenn.
McGraw-Edison Co., Macomb, Ill.
New Haven Porcelain Co., New Haven, W. Va.
Pass & Seymour, Inc., Syracuse, N.Y.
Porcelain Products Co., Carey, Ohio
Square-D Company, Peru, Ind.
Star Porcelain Co., Trenton, N.J.
Union Electrical Porcelain Co., Trenton, N.J.
Wisconsin Porcelain Co., Sun Prairie, Wis.

A number of agencies and libraries were very helpful in furnishing valuable data from their stacks and vertical files, but especially those listed below. I wish to thank the staff personnel of their research departments for their assistance, and a very special thank you to personnel in the two Arizona libraries for their patience while I spent hundreds of days and evenings wading through their patent books.

American Ceramic Society, Columbus, Ohio
Arizona State Archives, State Capitol Bldg., Phoenix, Ariz.
Carnegie Public Library, East Liverpool, Ohio
Hayden Library, Arizona State University, Tempe, Ariz.
Trenton Free Library, Trenton, N.J.

Insulator collectors throughout the country have contributed to this research by donation of specimens, reporting insulators and their markings, furnishing old catalogs and information from trade journals, studying dumpage at old porcelain plants I was unable to visit, etc. It would be impossible to list all these collectors and detail their individual contributions without fear of missing some names, but each one deserves a vote of thanks from me and all others interested in this subject. The published information on porcelain insulators is greatly enhanced by all these individual contributions.

PREFACE

This book was born out of curiosity -- a curiosity that started out modestly, but which grew to the point of being nearly an obsession. When I first started to collect insulators as a hobby, I found there was absolutely no published information on porcelain insulators which was of much help to the collector. I decided to research the subject and publish a collector-oriented book on my findings.

Almost immediately after commencing my research task, I discovered that porcelain insulators and the industry which produced them had an immense history, and it was necessary to set at least some guidelines for confining the research to obtainable levels. Generally the research was limited to information of interest to insulator collectors and to anyone who might in the future be interested in the history of the industry.

Even at that, the task seemed endless. There were so many porcelain insulator manufacturers involved. Hundreds of pertinent patents. Countless markings on the insulators. After making three extended research trips to visit all the defunct and active porcelain plants in the east, and after gathering data from the patents, insulator catalogs, old trade journals and all other historical accounts I could find, my information files were bulging. The more information I accumulated, the more obvious it was where key bits of information were missing, and the search became even more intensive. I have spent days in library stacks, travelled many miles, written many letters and scanned every piece of paper available just to learn one important date, or to locate one important patent. The search will never end. We now know what this gigantic picture looked like, but we will never find the last few pieces.

This book was also born out of fear -- a fear that the vast amount of data I have accumulated might be accidentally lost to future historians. I might die, or the house containing the files might burn down! Some of the information in my files is irreplaceable -- old plant sites being bulldozed away for freeways, people whom I interviewed having passed away, old files being discarded by newer managers in porcelain plants. It thus became of paramount importance to stop being curious long enough to draw a line on the research and publish the key information already at hand -- even if only a handful of books were printed and deposited in key libraries where future historians could find them.

Since the original motivation for the research was to gather information of interest to insulator collectors in general, I accumulated data on all forms of insulators, both porcelain and glass, and on some related items of interest to collectors. Even though this book is mainly devoted to dry press electrical porcelain, it is being used as a convenient means of publishing other data of interest to insulator collectors. This is especially true regarding the listing of insulator patents, since I have possibly the only reasonably complete file on insulator patents from 1880 to date. The tabulated patents carry no details except for their placement in various classifications, but the listing itself will allow others to locate all the patents of possible interest without duplicating all my patent search work. Similarly, this book contains some information (the registered trademarks, company names and locations, etc.) of companies who made related insulators of fibre, composition and lava.

While I continue to pursue my newfound hobby of "being curious", I dedicate this book to my fellow insulator hobbyists who still have time to pursue their hobby of "collecting insulators".

CONTENTS

<u>Chapter</u>	<u>Page</u>
1. The Electrical Age	
An electrifying event -----	5
Everyone into the act -----	7
Changing times -----	9
2. Evolution of Porcelain Insulators	
Surface wiring insulators -----	11
"Standard Porcelain" -----	15
Standard solid knobs chart -----	17
Porcelain insulator catalog pages -----	28
Insulator descriptions & terminology -----	53
3. Manufacturing Methods	
The nature of electrical porcelain -----	63
Preparation of the clays -----	63
Kiln Firing -----	64
The "wet process" -----	65
The "dry process" -----	65
Die Markings -----	66
4. Electrical Porcelain Manufacturers -----	69
5. Porcelain Insulator Markings -----	103
6. Insulator Patents	
The search -----	119
Better mouse traps -----	121
About patent procedures -----	123
Tod patent classifications -----	125
Patents with illustrations -----	126
Other insulator patents -----	157
Trademarks -----	168
Appendix A -- Patent Tuesdays -----	170
Appendix B -- Patent first-numbers of years -----	171
Appendix C -- Patent class 174 (simplified) -----	172
Reference Credits -----	175
Bibliography -----	176
Index -----	178

Chapter 1

THE ELECTRICAL AGE

AN ELECTRIFYING EVENT

Prior to the electrical age, power sources were limited to the water wheel and steam engines -- excluding, of course, the use of draft animals which originated eons ago.

Water wheels have been used for ages as a power source, but there is the obvious limitation that they can furnish power only where a source of water seeks a lower level. Until the advent of electrical power transmission, waterpower was necessarily very immobile.

The evolutionary process of steam power can be traced to the second century B.C., but it was not until 1698 that the first steam engine took a practical form and found employment in industry. This was the engine invented by Savery and which was used as a water raising device (pump).

Newcomen's first practical piston-type steam engine (1705) was being used in industry successfully by the 1720's and survived in the same general form for another 75 years or so. It became obsolete after perfection of the Watt engines, since the latter were much more efficient.

The steam power revolution can largely be attributed to James Watt's inventions. He discovered a way to make steam engines efficient by using a condensor to capture all the energy lost to the atmosphere by the other types of steam engines. He perfected his engine and obtained a patent on it in 1769, and a second patent in 1781. Two further patents of importance were obtained in 1782.

Power by steam engine progressed rapidly -- steam boats by 1802-1807 and trains by 1829. Steam engines became widely used in manufacturing plants in the 1830's, and it is proper to denote the 19th century as the "Steam Age". It revolutionized industry. Steam power had the advantage over waterwheels in that it was mobile. You could have steam power anywhere you wanted it by locating a steam engine there, even if you might have to transport boiler water and fuel to the site. Steam engines could also be used on moving platforms (trains, ships, automobiles). What more could one ask for? This was the ultimate.

The "Electrical Age" made a very quiet entry through a side door. It really began in 1881 when Thomas Edison invented the incandescent lamp. The event wasn't really celebrated at the time, other than people marveling at Edison's persistence to finally achieve this "stunt". When it was finally achieved, nearly everyone just said, "So what?". What could come of all this foolishness. Afterall, we already had good gas lamps.

Edison saw things differently. In 1882 he installed a 1200-horsepower generator in a New York warehouse and began furnishing power (at 1300 volts d.c.) to "subscribers" for operation of electric lights. They used existing telegraph lines with glass insulators in this power distribution network. The average citizen considered these new-fangled lights just a fad, and a dangerous one at that. When the city of Syracuse, New York was considering the installation of 148 electric street lights in 1882, an alderman introduced a motion "that all poles be enclosed by a ten-foot high wood paling fence in order that pedestrians would be protected from the dangerous electricity that would run down the poles on wet nights".

But the electric light was only the key that unlocked the door to the Electrical Age. It was the first excuse to transmit electrical power through a city on pole lines. In the following year, a New York grocer became the first person to use transmitted electric power for a purpose other than lighting when he hooked an electric motor to Edison's line and connected it to his coffee grinder. The first electric railway came into use in 1885 when Richmond, Virginia converted 12 horse-drawn trolley cars to electric motor drive. The "fad" obviously wasn't dying out; it was spreading.

Demand for electric power rose explosively in the 1880's, and there was rapid evolution in all phases of power generation, distribution and types of loads. The first Alternating-current system was put into operation at Great Barrington, Massachusetts in 1886. This type of system with its step-up and step-down transformers allowed power transmission at very high voltages to reduce the loss in power lines, and also distribution to consumers at lower voltages. Serious electrical shocks were proving to be a big problem with the 1300-volt distribution system.

Power lines were being constructed in the eastern cities as fast as poles could be set. Some cities and localities had dozens of separate power generating companies, each supplying different distribution networks. This hodgepodge of small systems was naturally very inefficient, and it is not surprising that by the early 1890's most power distribution had fallen into the hands of our pioneer electric utility companies who bought out little companies in rapid order.

By the mid-1890's things came full circle. The generators which had been powered by steam engines were in many instances moving backwards one notch to utilize water power (Niagara Power Co. being the first). This all became possible when power could be transmitted at high voltages. So here was the big difference. The waterwheel could furnish power only on falling rivers, and steam engines could furnish power only at locations where they were physically installed. The electric power systems could furnish power wherever a couple of little wires could be strung. Anyone could now have power even if he didn't live by a waterfall.

The early central-station companies were purely lighting companies, and they tended to have short distribution lines serving concentrated or central downtown districts of the bigger cities. Industrial power loads (motor drives for machinery, street railways, fans, elevators, etc.) had become established by the early 1890's and surpassed the lighting load by 1900. Increased use of power for uses other than lighting gave further impetus to wider distribution systems and this, in turn, caused lighting to become very wide spread. By 1920 approximately 9,000,000 residences in the United States had been electrically lighted, any 98% of the newly constructed residences in cities where power was available were electrically equipped. Still, the other 15,000,000 of the 24,000,000 residences were not yet wired for electricity.

Power distribution and house wiring continued at a frantic pace for a number of years. Everyone wanted electric lights in their home, but they also wanted use of electrical appliances which were being created at a rapid rate. Over a period of years, virtually all of the cities and towns had electric power throughout. By the end of the 1950's virtually all of the rural sections had electric power through the private and federally sponsored Electric Cooperatives.

Yes, the "fad" of the 1880's was here to stay. Doing things electrically has become so much a part of modern life that it is impossible to think of what it would be like without electric power. Well, not quite, if you look at what happened when they had the big power outage in the New England area in 1967, or what happened in New York City on a hot July 14,

1977 when the power went off for 24 hours.

How important is electricity to us? Just ignoring the use in transportation, industry and other applications where absolutely everything screeches to a halt when the power goes off, let's look at the average household. Assuming I could always read in the dark by lighting up a few candles, and that I could always put on a thick coat when the electric furnace conks out, what else would we be left without when the power goes off? I've gone about the house and listed the various gadgets run by electric motors, and it comes to 37 items! Oh, you don't believe that? Well, here they are:

1 Refrigeration compressor	1 Shop lathe
1 " heat exchanger	1 Tool grinder
1 Refrig-furnace blower	1 Can opener
1 Food refrigerator	1 Lawn mower
1 Deep freeze	1 Grass edger
1 Orange juicer	2 Hand drills
1 Food mixer	1 Circular saw
1 Food blender	1 Saber saw
1 Vacuum sweeper	2 Portable fans
1 Floor polisher	1 Adding machine
2 Hair dryers	1 Razor
1 Sewing machine	1 Night-light timer
1 Record player	2 Timer clocks
1 Clothes dryer	3 Clocks
1 Timer in dryer	2 Clock radios

If you think it's inconvenient around the house when the power goes off, think what it's like in a big office building, in a big manufacturing plant, in a steel mill, in the traffic signal systems, on an electric railway. For one world power to knock another flat on its back, all it has to do is have a few spies toss hand grenades into several key power transmission lines or hydroelectric-station transformers. All the fancy missiles and hydrogen bombs are unnecessary!

EVERYONE INTO THE ACT

When first there was a demand for wiring insulators in the 1880's, porcelain insulators were made by companies already making ceramic products. Not only was the market reasonably limited for several years, but wooden insulators were an acceptable item and were gaining wide useage.

By 1891, insurance companies would not tolerate the wooden wiring insulators because of the fire hazard, and simultaneously the demand for wiring insulators became very great. It was at this time that a number of companies manufacturing ceramic products commenced to also manufacture electrical porcelain insulators. Several other companies were founded to manufacture electrical porcelain exclusively, one or more of the founders usually having departed from some chinaware factory for that purpose. Other industries (wire, poleline hardware, fixtures, appliances) also had their big upstarts in this same period. The industry growth was limited only by the evolution of power generation and transmission during the 1890's. The manufacturers of wiring insulators were kept very busy, but they were able to meet the demand.

Shortly after 1900 though, there was a step change in the electrical industry. Practically overnight the status went from merely robust times to real boom. In a few years, it became a super-boom. Not only had the "fad" interpretation of the electric light changed to a "must" outlook in the first 20 years since Edison's invention, but the few remaining problems of high-voltage power transmission were rapidly being solved. Just as with any boom when existing manufacturers are running full capacity to try to meet the demand, outsiders saw the opportunity to enter a very lucrative business. The business of insulator manufacturing was certainly no exception. Everyone wanted into the act.

Nearly all the companies who were making porcelain or semiporcelain products (from door knobs to chinaware and bathroom fixtures) considered entering the electrical porcelain business to one degree or another, and many did. An even more noticeable event was that of individuals pulling out of various ceramics operations and starting up porcelain insulator plants down the street a block or so. This was probably a case of people wanting to make hay while the sun was shining. Some of the quite large porcelain insulator plants were started in this manner, and there were a large number of hole-in-the-wall operations that suddenly emerged.

It was very easy to get started in the business, and especially for companies already making ceramic products. They had the clay handling machinery, the die presses, the kilns. Even for the newly formed insulator companies, this equipment was easy to build or cheap to purchase. The larger companies made a varied line of electrical porcelain, but the small, fly-by-nighters wanted to get into the most visible and lucrative part of the business -- nail knobs and cleats for house wiring. Most of the very small operators made only nail knobs.

Any knobs an operator could make were instantly gobbled up. Quality meant nothing at the height of the activity. Manufacturers and jobbers guaranteed their products; if the knob broke and your house burned down, just bring back the broken pieces, and we'll give you another knob! Some nail knob plants were unbelievably small and crude, and their products were likewise crude. At least several plants in East Liverpool, Ohio and Trenton, N.J. had only one small kiln and occupied about the same amount of space as does my carport and driveway. They certainly must have been two-man operations at the most -- there not being room for a third man.

It was practically standard procedure for the companies, even the very small ones, to dream up some alleged improvement in nail knobs and apply for a patent on it -- and which was usually granted. In fact, any conceivably novel design for a nail knob had already been patented, so it was almost a necessity to get your own patent on a nail knob to commence any production. Many, if not most, of the patents granted for so-called improved designs should not have been granted (see Chapter 6 text). Most companies marketed their knobs under catchy tradenames which inferred the knob was much easier to install, or held the wires more securely than any other knob on the market. Few of these "PRESTO"-type tradenames were every registered with the U.S. Patent Office.

There was an even easier way to get into the insulator act without building an insulator plant and working with all that slippery clay and toiling away at the hot kilns. You just formed your own "porcelain company" and had the little fellows make your wares for you. Your catalogs were as fancy as the regular insulator manufacturers and listed your own "factory locations" at the addresses of your suppliers. You sold under one or more of your own tradenames (J H Parker used eight tradenames for solid and split knobs alone!).

When I first started the research, it appeared from the tradenames, patents, catalogs and old directory listings that there were a great many manufacturers operating plants to make wiring insulators and other standard porcelain. It soon became obvious that some of these were jobbers of the insulators or operating as pseudo-factories. The only way to learn which companies actually had manufacturing facilities was to physically visit all the addresses involved -- and that was done. From all evidence it would appear that Trenton Porcelain Company was one of the largest porcelain insulator manufacturers. However, if you visit their address of 803 E. State St. in Trenton, you learn that all they had was a small office room with a desk, telephone and pad of order blanks. All of their electrical porcelain was made by Ohio Porcelain Co., Findlay and others. (By the way, if you visit that Trenton address, I recommend you do so in the middle of a sunny day and that you stay in your car with the windows rolled up and the doors locked.)

The electrical porcelain boom that got underway around the turn of the century lasted up until the start of the great depression. However, many of the smaller companies faded from the scene along the way. Larger companies with more complete facilities, good marketing organizations and reputations for better products survived and prospered. The very little operators just kept melting away. Marginal companies were occasionally bought out by the stronger companies, as was the case when several were merged in 1913 to form General Porcelain Company which, in turn, merged with four other companies in 1927 to form Porcelain Products, Inc. All of the small companies which were busy making house wiring insulators as their sole product in the boom period were out of business by 1932.

CHANGING TIMES

The depression that commenced in 1932 was particularly severe to all insulator manufacturers, and especially to any small company or any that manufactured primarily house wiring insulators of any form. Residential construction essentially ceased, and electrical wiring of older homes was at a standstill because utility companies were not expanding the electric distribution systems in residential or urban areas.

Simultaneously, building codes were being revised by many government agencies at all levels. Except in some rural areas, the open wiring with knobs and tubes was no longer permitted. Under the most strict codes, all commercial and residential wiring had to be in metal conduit systems. The nail knob boom was over. They were now like buggy whips. A number of the larger electrical porcelain manufacturers survived because they had a diversified product line. It should be noted that many companies had already been making other products -- anything from very specialized electrical insulators to towel racks.

Electrical porcelain in the form of "standard porcelain" insulators is still manufactured to this day, but it is a very small percentage of the total amount of dry process porcelain insulators manufactured. Many forms of dry process insulators are manufactured today, and the quantity of electrical porcelain made now far exceeds the quantity made in record years during the nail knob boom. The companies that have survived and prospered are those who changed their product lines and technology to fit the times. Most of the companies that formerly manufactured both dry and wet process porcelain insulators now manufacture only or mostly wet process insulators.

The sole surviving company operating as a manufacturer of standard porcelain insulators by dry process is New Haven Porcelain Co. (W. Va.). They had a good chance to call it quits in 1970 when their entire plant burned to the ground, but they rebuilt and carried on; the industry has at least one survivor yet. There are several other manufacturers making lines of dry process insulators, but they are either making specialized forms of insulators or also manufacturing wet process insulators.

Chapter 2

EVOLUTION OF PORCELAIN INSULATORS

SURFACE WIRING INSULATORS

When Edison ran the first electric power down a New York street over a regular telegraph line in 1882, no telling what types of insulators were used to take the power into "subscribers" buildings and route it around to the series lamps (the power was 1300 v.d.c.). Undoubtedly the scheme was a very mickey-mouse affair, and the hazards of serious electrical shock and fire were ever present.

Wood is a reasonably good insulator and especially under normally dry conditions inside buildings, and it had long been used as the inside insulation for telegraph and telegraph wires and terminal equipment -- the telegraph keys, sounders, etc. Interior telegraph lines were strung with insulated staples and small wooden cleats. Anything would suffice. It was only natural then that the first electric light wires strung into buildings were secured to the rafters and walls by wooden cleats, and the switches, fuse cutouts and sockets were also of wood. Pictured below are examples of the wooden insulators of the 1880's (specimens courtesy of Fred Richardson, Ouray, Colorado).

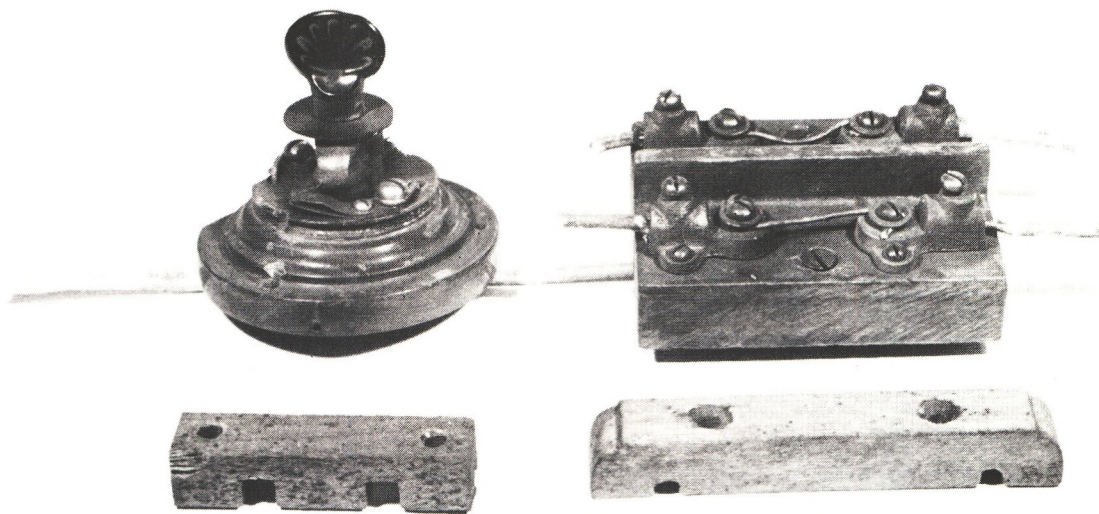

The wiring with wooden insulators was extensively fused, and note in the photograph that both sides of the line were fused in the cutout; it was possible that some early systems operated ungrounded. Most of the early switches, sockets and ceiling rosettes also had a series fuse wire inside the base, and this carried over into porcelain wiring insulators for a number of years after they entered the scene. All of this fusing on early wiring consisted of ordinary fuse wire mounted under screw terminals. Plug-type and cartridge-type fuses came about much later.

When a short circuit occurred in the wiring, one or more of the fuse wires supposedly blew out, and everything was fine. However, occasionally the circuit was inadequately fused, or a short occurred in a portion of the wiring where a fuse had been temporarily replaced with an ordinary

wire. The results were obvious. White-hot wires immediately ignited the wooden insulators or the rafters to which they were attached and resulted in an instant conflagration. Needless to say, insurance companies started to take a beating on houses wired with wooden insulators.

At least two companies had been making porcelain wiring insulators in the 1880's, and houses using these insulators were much less prone to burning to the ground when short circuits occurred. (Although the wooden insulators were perfectly good for the electrical insulating function, they afforded no heat insulation.) When shorts occurred with porcelain insulators, the white-hot wires just sagged and sizzled through the porcelain insulators, but naturally porcelain won't burn. If all the wires were kept away from close contact with the wooden structure, fewer fires would occur. People demanded the safer porcelain insulators even though they were more expensive, and this was the real start of companies formed for the express purpose of making porcelain wiring insulators. This was in the 1890-1892 period.

The following quote from an October 1892 trade magazine is in reference to a newly patented two-wire porcelain cleat made by Pass & Seymour (founded in 1890): "The cleat ... is intended to take the place of those of wood, now in general use." In November 1892, in reference to a newly patented adjustable 2-wire porcelain cleat by E. G. Bernard Co., there is this remark: "The accompanying illustration shows a new form of china cleat especially designed to meet the requirements of insurance experts, who have recently prohibited the use of wood for this purpose."

There were several patents in the 1883-1889 period for wiring knobs and cleats, but design evolution really got into full swing in about 1892. All the early emphasis was on cleats, and the 1891-1895 patents on them are numerous (see Chapter 6). The evolution is partially illustrated by the cleats shown at the right.

Figure 1 shows an early cleat without wire-positioning grooves. Although the long transverse grooves in the base piece do help hold the wires in place, they can slip out on their own accord or with a slight tension applied to the wire. The mating cap on this cleat has a plain, ungrooved surface.

Figure 2 illustrates a cleat with two significant improvements. Most importantly, it has wire-positioning grooves to keep the conductor from slipping free of the cleat. Secondly, both halves of the cleat are alike (reversible). This greatly simplified the production and stocking of cleat parts, not to mention simplified installation.

Figure 3 shows a further improvement in retaining the wire firmly in the end grooves with small dimples added inside the groove. There was a similar prior patent (11-14-93) for annular corrugations in the groove that served the same purpose. Note also that the transverse ribbing was shortened to occupy only the end area where it came into play. This cleat is also "reversible".

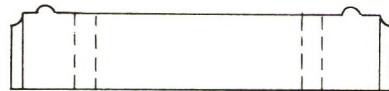
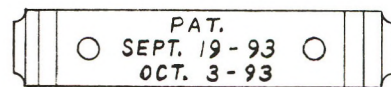

1.

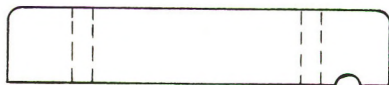

2.

One cleat feature patented early in the game (10-3-93) and illustrated in Figure 1 above was the addition of spacer ridges to hold the cleat away from the mounting surface. Without these spacers, some cleats are broken when nailing them to slightly irregular rafters and walls. This early Buffinton & Dow patent prevented other companies from using this feature, but a later patent for circular bosses around the hole for the same purpose was widely licensed to others. Even it expired before the wiring boom ended.

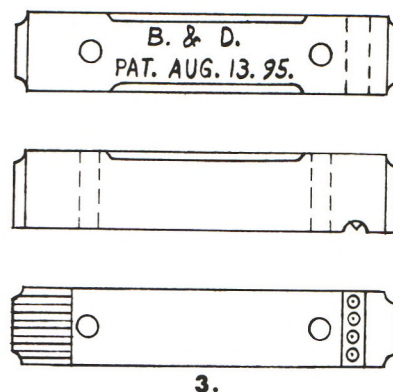

Essentially all the cleat evolution (and consequently the patenting) was over with by 1895. There was a trickle of later patents, but these were for specialized cleats and for reversible wiring cleats that weren't really very practical. The simple reversible cleat patented 11-14-93 by Duggan (Imperial Porcelain Works, Trenton, N.J.) is essentially identical to all cleats made by all companies throughout the era of surface wiring (the patent having expired in 1910).

The era of cleats for surface wiring was very short. Although there was always a continued use of cleats for ceiling wiring, an easier method of attic wiring evolved -- nail knobs. Split knobs are more versatile than the 2-wire cleats, allowing the wire pairs to be run with any degree of spacing, causing less problems at bends and corners of the route, etc. But the one overriding advantage of knob wiring is that it is infinitely more simple to install. If you think cleat wiring is easy, just try it. It's no easy task to string two wires tightly over your head at one time while trying to hold two halves of a cleat and a nail in one hand while swinging a hammer with the other one. It really helps if you have about three or four extra hands attached to your body. Stringing single wires through the side notches of nail knobs and swatting them down is simple.

Ironically, a split knob was patented April 8, 1884 which was essentially identical in principle to the split knobs which 30 years later were the hottest selling item on the market. It was just too early for its time. The insulators used in the 1880's were made of wood, and if you will look at the photos of wooden cleats previously shown, you can see that it is easy to fabricate these in cleat form, but it would have been difficult or costly to make these in one-wire knob form. Two-wire cleats were the only way to go.

Two-wire porcelain cleats quickly entered the scene in 1892 when the insurance companies all of a sudden had it up to their ears with fires caused by wooden cleats. The several porcelain companies weren't about to bring out some radically new design; they just copied what was then being used. The two-wire porcelain cleats had their real heyday in the 1890's and on up until about 1910. At least two other perfectly good split-knob designs were patented in 1889 and 1890, but did not make any inroad into the insulator market because of the cleats.

The difficulty of installing wiring with the two-wire cleats became more frustrating as time went on, and the number of electricians entering the trade to cuss cleats was increasing at a phenomenal rate. Certainly it must have dawned on a lot of people that there had to be an easier way to install insulators. There was a trickle of insulator patents in the

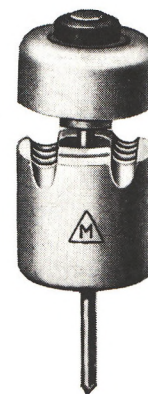

1890's and then a few more in the 1902 to 1905 period, and they all seemed to have the same theme -- one wire per insulator.

Hunt-Snyder came close to a winner with their 1904 patents by brute force reasoning. These were merely rectangular cleats held with a single nail or screw and with a groove at the side for a single wire. Well, at least that's what was needed -- one wire per insulator.

Sinclair patented in 1905 a split knob (oval in shape) which had all the requirements -- one insulator per wire, a single mounting screw, and means for captivating the parts together with the screw. Sinclair also had an adjustable, two-piece knob patented in 1907 (see Patent #855,208). The difference from the other inventors was that Star Porcelain Company (Sinclair, president) widely advertised their products, and they started to spread the word about the advantages of split knob insulators over the two-wire cleats for the unexposed wiring in attics.

The first patent (Gordon, #845,544) for a split knob essentially of the same form as all later "nail knobs" was granted in 1907. Following very quickly was the "nail knob" patent #864,947 by Buffinton & Dow, who were already well known in the trade. They had some very basic patents on cleat construction. The methods were so widely licensed and used that these forms of cleats came to be known throughout the trade as "B & D Cleats". With Buffinton & Dow patenting nail knob designs, these must be the best and most efficient wiring insulators.

Not only were these various split-knob designs of 1907 immediately accepted by the trade as the best way to install surface wiring, but this also came just as the house wiring boom was really working up steam. The little companies that were rapidly springing up to make wiring insulators made only one insulator and in great quantities -- nail knobs.

As related previously, cleats continued to be manufactured, but they became a very small part of the picture after about 1910. Attic wiring was being done with porcelain tubes through the walls and nail knobs on the rafters and ceiling joists. The wiring method became known universally as "knob-and-tube wiring". There was a continuous flow of nail knob patents from the first ones in 1907 up until 1923, and then they quit as if a faucet were turned off. This period coincides exactly with the boom period for little insulator companies, and where it was the vogue to get your own nail knob patent and catchy tradename to enter the business.

During the heydays of two-wire cleats in the 1890's, there were only a handful of manufacturers, and only four of those had essentially the entire market. The cleats generally were marked only with the mundane name (or initials) of the manufacturer and sometimes with only a patent date and no name at all. In later years cleats were made for many electrical companies and jobbers and were marked with a number of names (many of which remain unattributed), but there is a conspicuous absence of the "GEE-WHIZ" and "PRESTO" tradenames which are usually prominent in markets where there is strong competition between manufacturers.

Not so with the nail knobs. A few companies merely marked them with only their initials, but the great majority marked the knobs with catchy tradenames, usually with regard to how well the knob held the wire or how easy the knob was to install. For example, here is a sampling of names touting the wire-gripping ability: ALLIGATOR, BULL DOG, GRIP-IT, HOLD FAST, WEDGE. Examples of tradenames touting easy installation: CINCH, EVEREADY, IDEAL, JIFFY, NAILIN, NAILIT, READY, SCREWIT.

There are a number of special surface wiring cleats and knobs which were patented throughout the earlier years, but there is one class that deserves mentioning -- self-tying knobs. (The patents on all these items are shown in Chapter 6.)

A number of these were probably designed and patented by people who just wanted to be different, and some were rather impractical. The main reason for these items was to allow the cleats or knobs to first be installed and then the wires run in later. Some were made as proprietary items and listed in regular manufacturer or jobber catalogs. Others were probably the requirements of a special application or were made to order for the person who created the design.

Since all of these knobs with a couple of exceptions were early and specialized items, it is not surprising that specimens are very scarce to rare. I know of no specimens extant of some self-tying knobs and cleats. Similarly, specimens are unknown for all of the special cleats shown in the patent section (Chapter 6) if the cleat is obviously impractical from any standpoint. It seems no company was interested in making items which obviously wouldn't sell.

Aside from the cleats and knobs, there was one other insulator used in large quantities for house wiring. This was the "tube", and they were used to insulate wires through building walls and floors. The large mass of tubes used in ordinary house wiring were the headed, straight tubes of standard diameters and lengths. For special applications and commercial wiring, tubes were made in a great many diameters (up to several inches) and a great many lengths (up to 2' and longer). Some porcelain manufacturers stocked and cataloged a tremendously large variety of diameter and length combinations, and it was possible to obtain literally any length and diameter combination for special applications on order.

Companies also manufactured "split tubes" (which were half-tubes by splitting the tube lengthwise). These tubes could be easily installed around the conductors after they were already run through the wall holes. Also available as standards and on special order were unheaded tubes and curved tubes (for use at wall corners and for wire drops). Except on special orders, wall tubes were normally furnished unglazed.

There were eight patents (1892 to 1916) on ordinary wall tubes, and most of these involved methods to retain the tube in place in the hole. (See Chapter 6, Tod patent class #35.)

"STANDARD PORCELAIN"

The very rapid growth of the electrical power industry in the 1890's inevitably led to a rapid state of confusion regarding acceptable methods of electrical construction and the forms of electrical apparatus turned out by a very large number of manufacturers. This randomness of material specifications and installation methods not only became a factor in the increased incidences of electrical shocks and fires, but it was creating a staggering variety of manufactured electrical equipment, especially the insulators and wire used for over-surface wiring inside buildings.

Naturally the ones most concerned with these problems were the fire insurance companies, and they were the first to act. The National Board of Fire Underwriters founded the Underwriters' Laboratories, Inc. in 1894 to formulate safety standards for the industry. Up to modern times there have been numerous agencies and national associations involved with these matters, and it is beyond the scope of this book to detail the history of the various standards and codes which have evolved.

The National Electrical Code was first published in 1897 as a result of a national conference of engineering and underwriters' organizations,

and it has been periodically revised and expanded throughout the years. The Code was initially a set of rules relating to electrical installations and which were intended to prevent fire hazards, and one major section of the Code set forth standards for the materials, fittings and details of their use in electrical construction. Of interest to us here are the standards for porcelain insulators used for over-surface wiring.

The initial effect on insulators for house wiring was to standardize the forms of two-wire cleats and tubes then in use for this purpose. The standards subsequently included minimum specifications for nail knobs as they came into wide use a few years later. Of primary importance from the standpoint of fire and electrical shock were spacing of the conductors from the mounting surface and from the nail or screw used to secure the insulator. Eventually the standards even spelled out other dimensions of the insulators not involved with those factors.

Standards were also set for two other large classes of insulators which were used for surface wiring in structures other than residences. These were one-wire cleats and all forms of solid knobs. It might seem that only a small variety of insulators would be involved once standards were created, but this was not the case. Cleats had to be made for very large numbers of different conductor sizes and for varying electrical and mechanical loading factors. Knobs had to be made for an equally large number of different applications. Even at that, the Code did put a stop to the unrestrained growth of a myraid of insulator styles manufacturers were turning out.

It was fortunate that the standards were adopted as early as they were in the industry. This was before the super boom period in electrical wiring got underway. The manufacturers involved early in the game had to make only slight changes in their products, since most of the cleats and knobs made in any quantity were essentially included with only very minor changes in the standard porcelain charts. Companies entering the porcelain insulator business after the adoption of the Code made products which complied with the standards.

Not surprisingly, all the porcelain insulators used for surface wiring soon came to be known as "Standard Porcelain", and many manufacturers restricted their activities to these items. Most of the very small companies coming upon the scene in boom times made only the high-volume house wiring insulators, and the larger companies made more extensive lines of standard porcelain. Catalogs of several of the larger manufacturers had listings for virtually every size and style of standard cleats, knobs and tubes. In the case of cleats and knobs, this involved a tremendous number of dry press dies in their tooling department. In the case of tubes, it created a very large inventory of finished products. Even with porcelain insulators fairly standardized, it must have been a chore for jobbers and distributors to handle the large variety.

As differentiated from "Standard Porcelain", all porcelain insulator products not included in the standards became known as "Specialty Porcelain". Except for the very small nail knob companies in the super boom, nearly all electrical porcelain manufacturers made specialty porcelain to varying degrees, even if their main product was standard porcelain. This specialty porcelain was occasionally a proprietary product, but generally it was made on contract for other electrical manufacturers.

Manufacturers of standard porcelain tended to follow the Code in the more important features such as overall insulator size, hole diameter, groove size, etc. Standard knobs and cleats by various manufacturers did vary with regard to unimportant details such as crown curvature, beveled corners, base counterbore shape, etc. There was also some discrepancy on outline dimensions and numbering methods used by various companies. For

instance, some companies list the # $3\frac{1}{2}$ knob as a #3 W.G. (wide groove).

The Standard Porcelain chart for solid knobs is shown on the following pages. There was one major revision of the knobs in the Code wherein some items were deleted, others added, dimensions of some changed. Sizes shown are generally for the New Code (N.C.), but both sizes are shown for the # $5\frac{1}{2}$ (which is the proverbial nail knob in split form, $5\frac{1}{2}$ -split). The chart is nominally for solid knobs, but split knobs normally used as forestry insulators are also shown; these are the Victor #22, #37-Split and #38-Split.

As you can see, there was a "standard" knob for virtually every use. It would be interesting to know just what pull some manufacturers had to get obviously proprietary knob designs included in the Code -- notably the #17, #18, #35 and the electric fence items #57 and higher. Some of the numbers were commonly used in many types of wiring installations, but others were probably made for rather limited applications.

In lieu of including similar charts and tables for the many forms of split knobs, one-wire cleats, two-wire cleats, and tubes, I have included after the solid-knob chart a selection of pages from various old catalogs which serve to illustrate the insulator lines manufactured and sold.

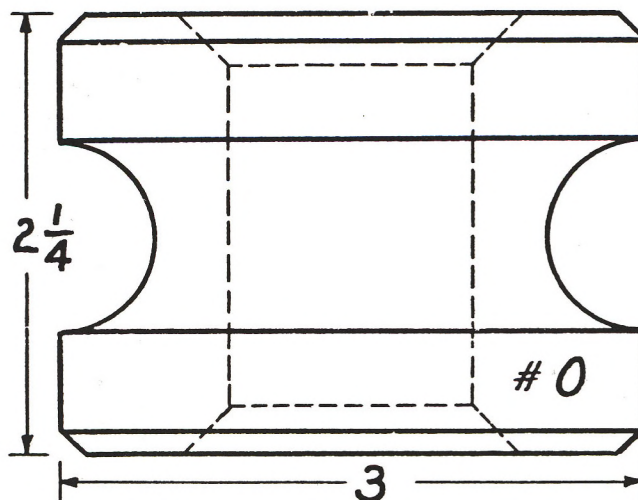
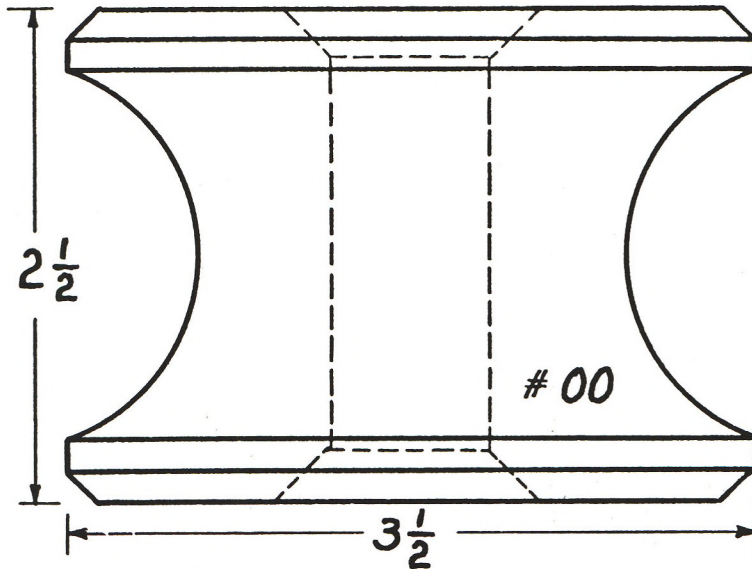

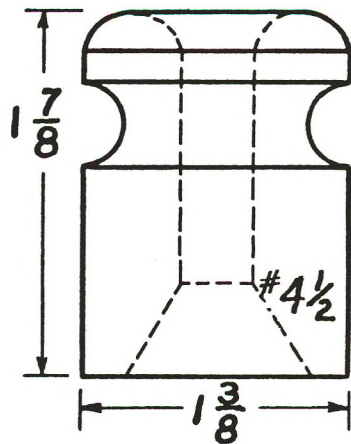
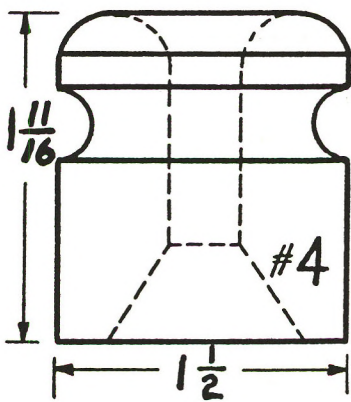
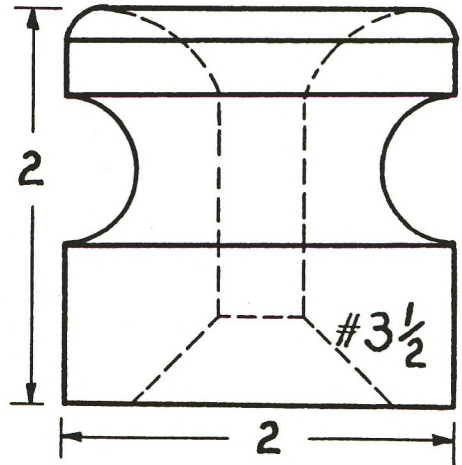
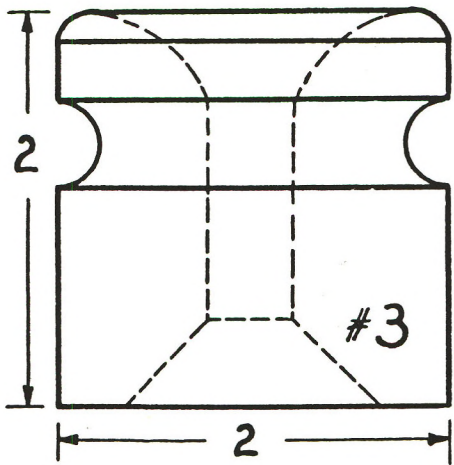
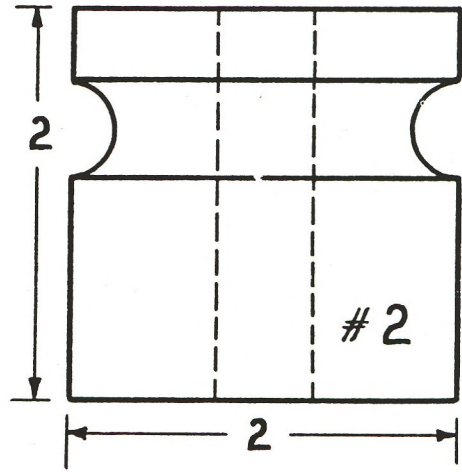
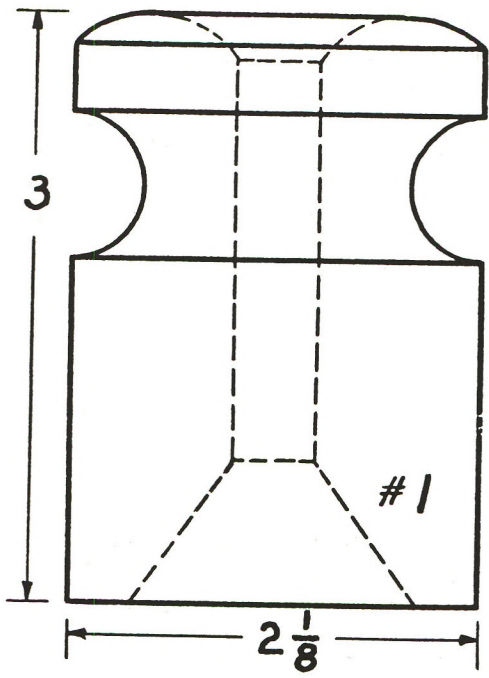

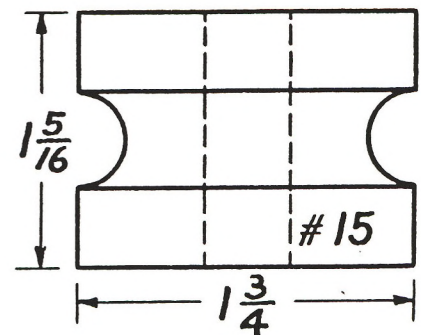
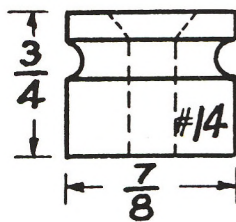
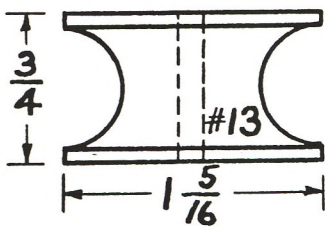
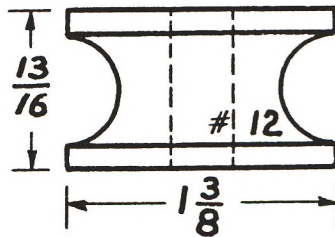
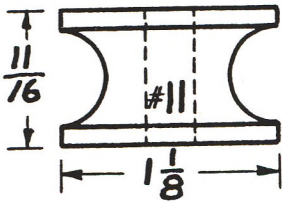
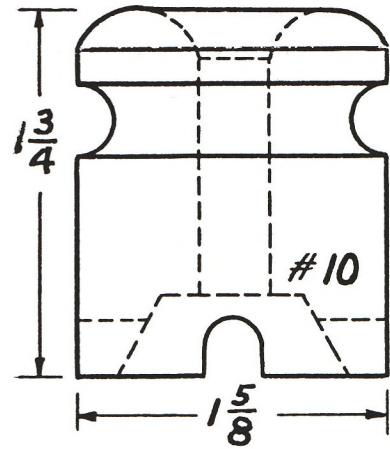
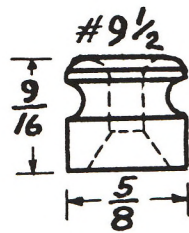
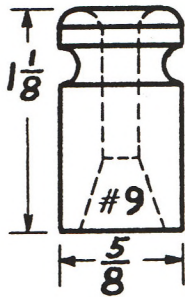
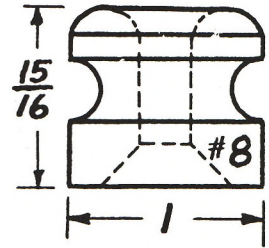
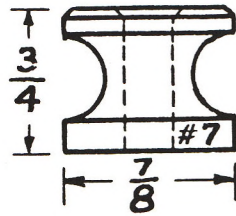
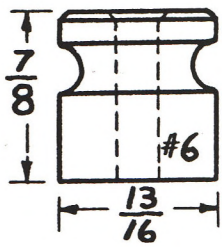
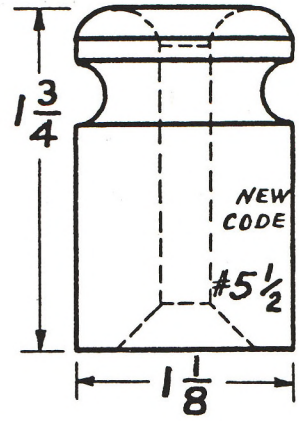
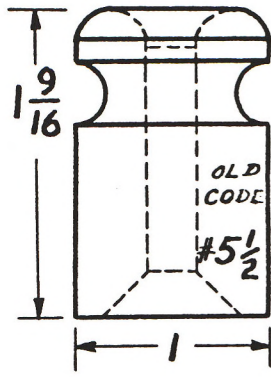
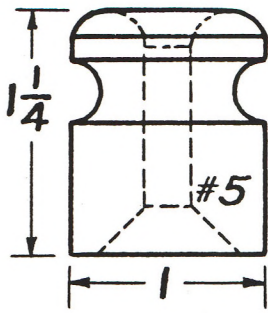

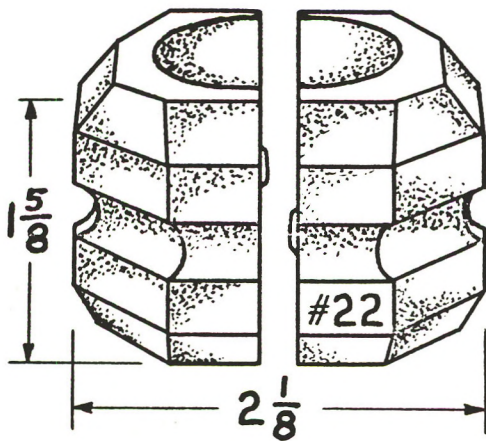
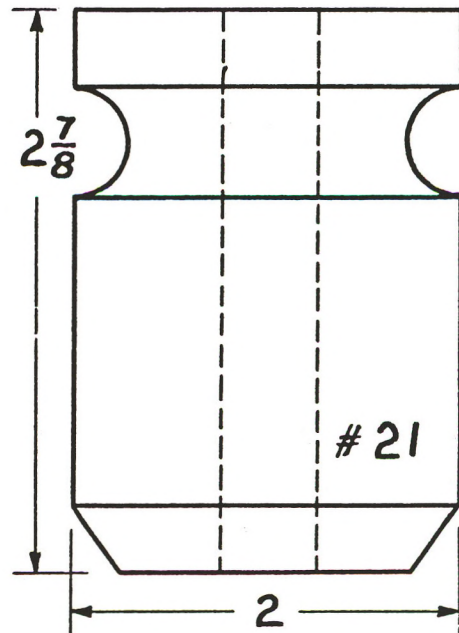
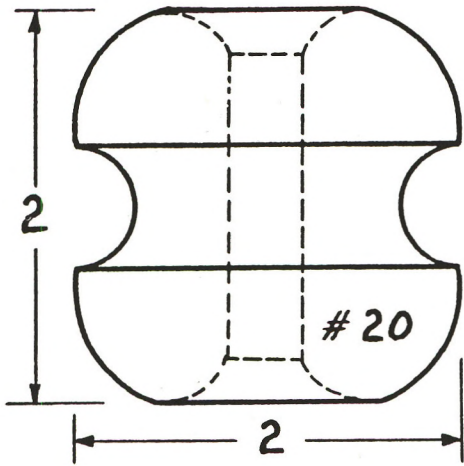
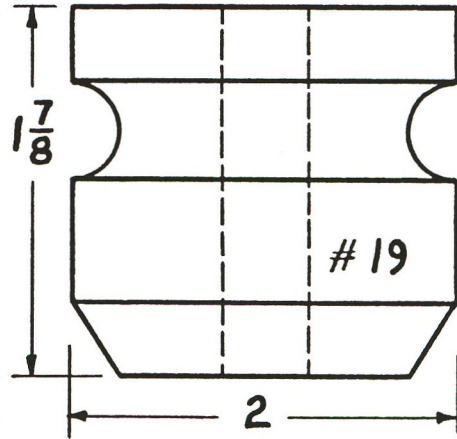
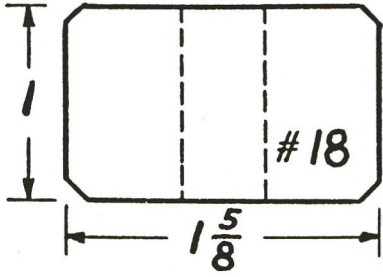
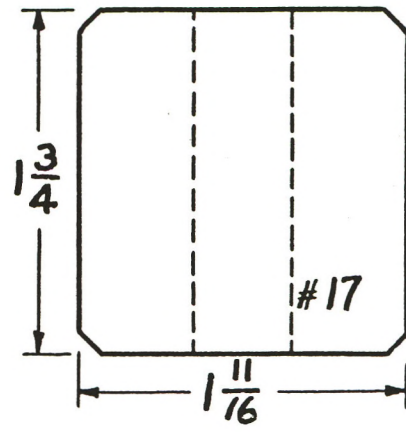
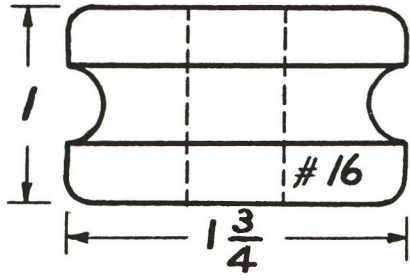

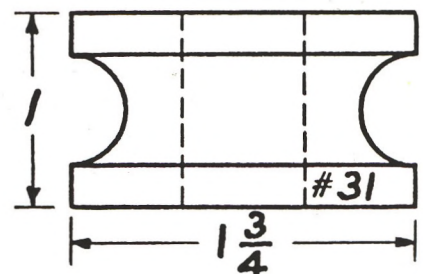
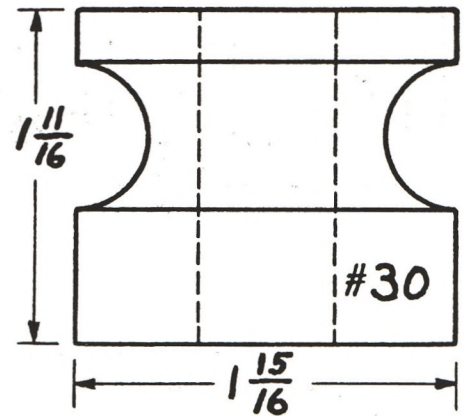
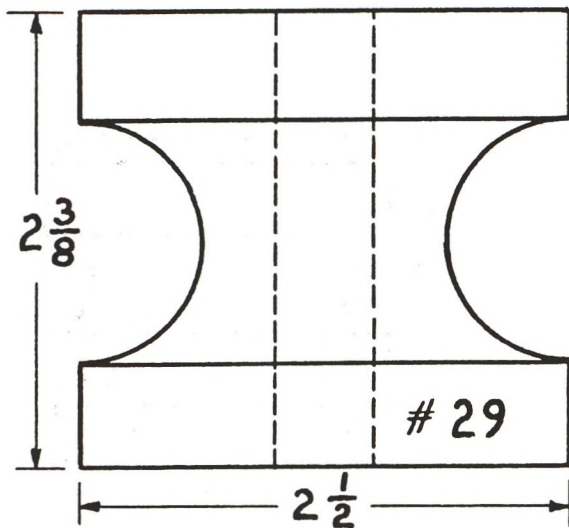
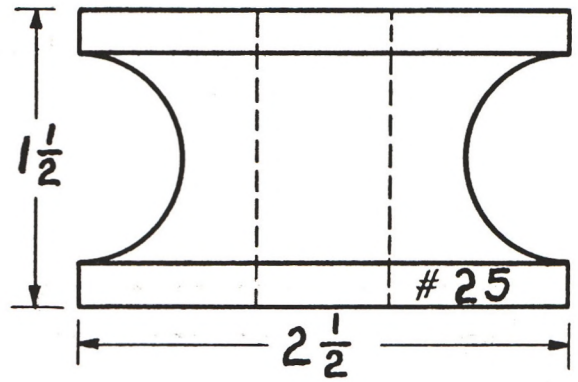
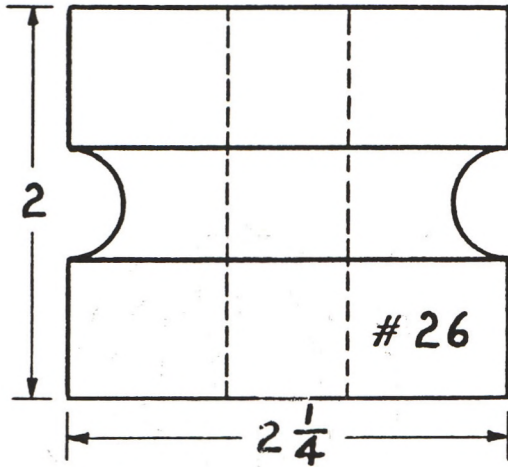
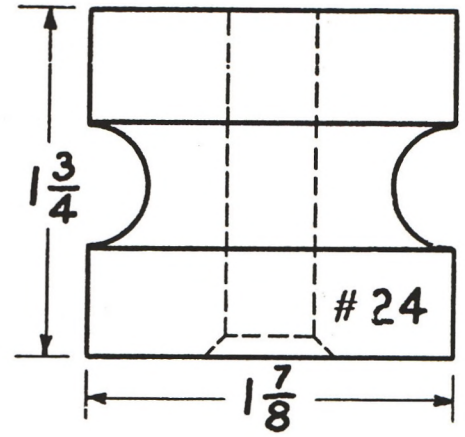
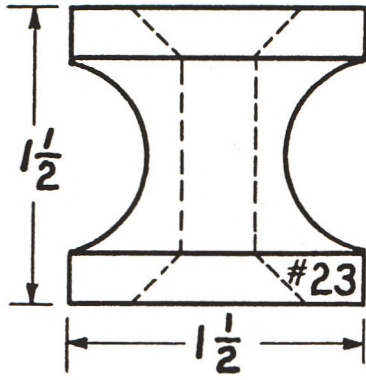

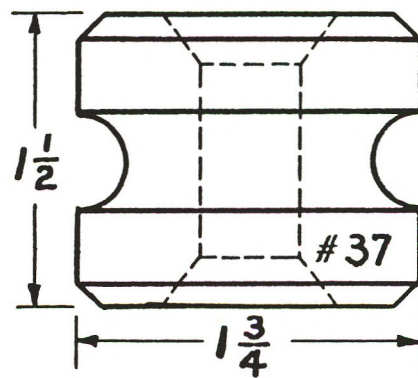
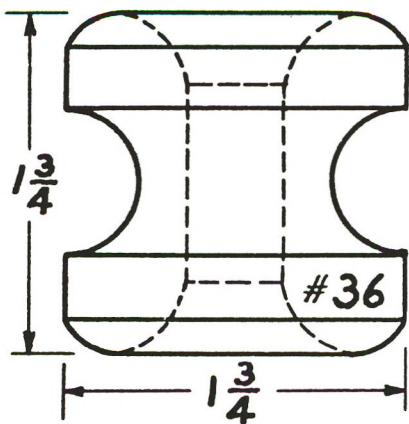
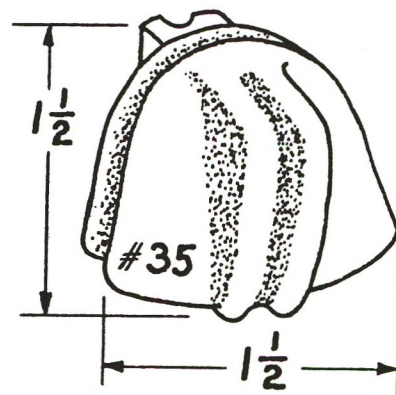
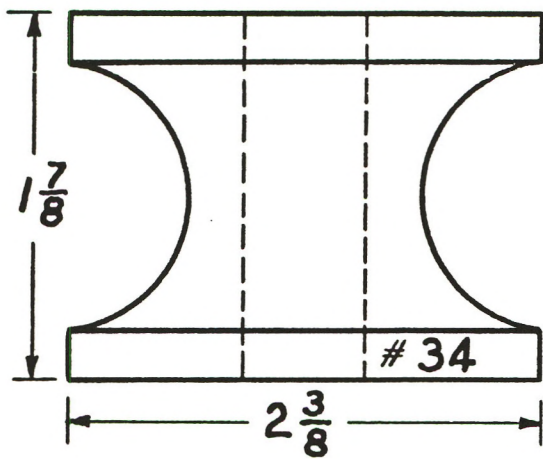
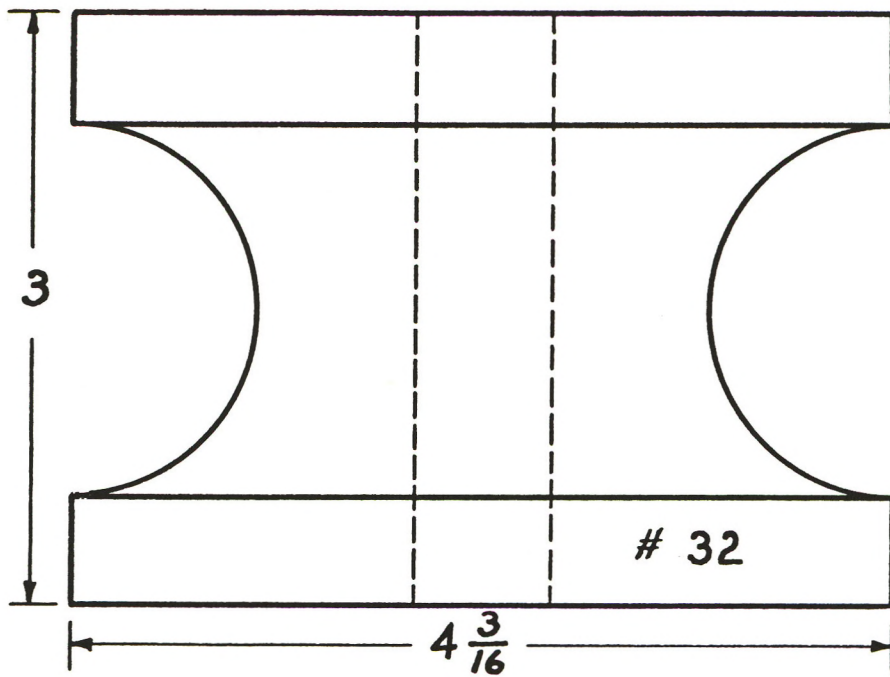

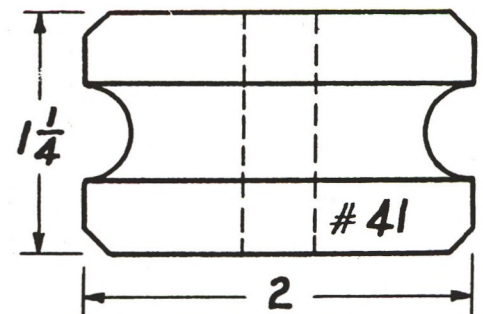
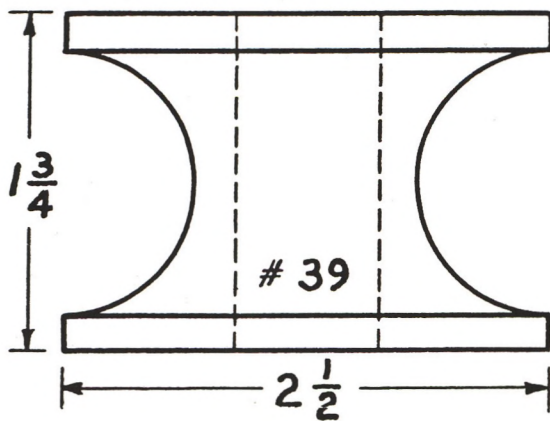
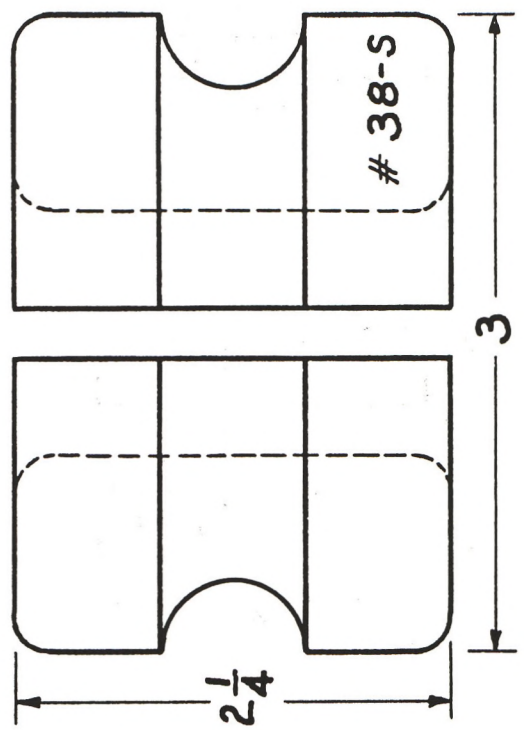
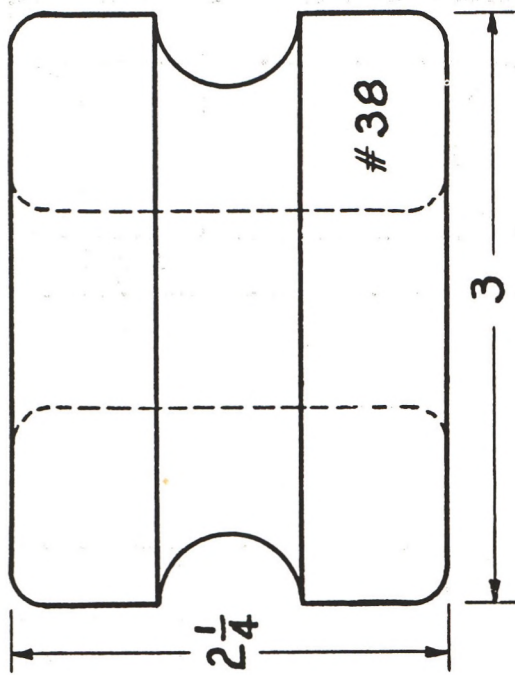
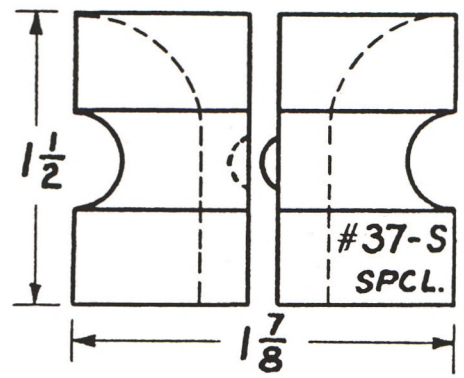
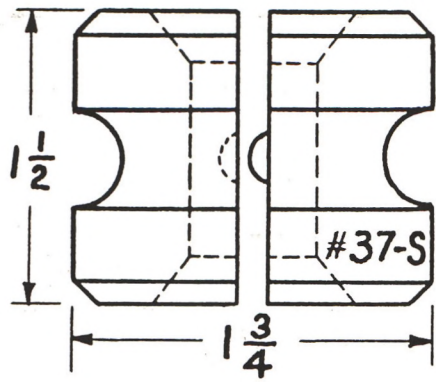

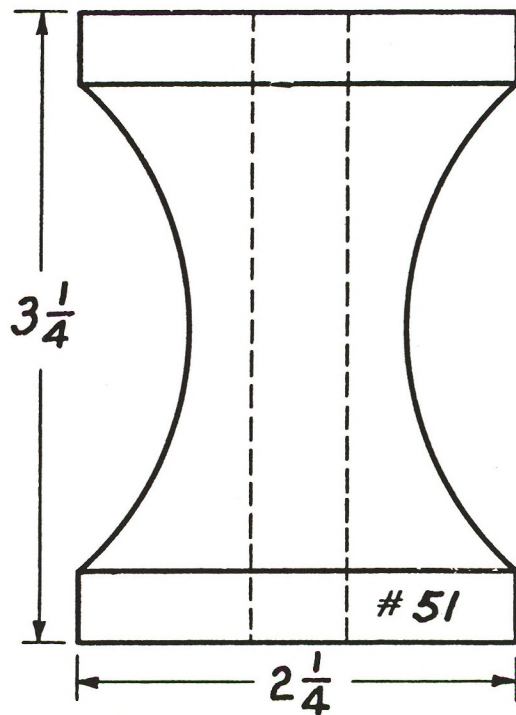
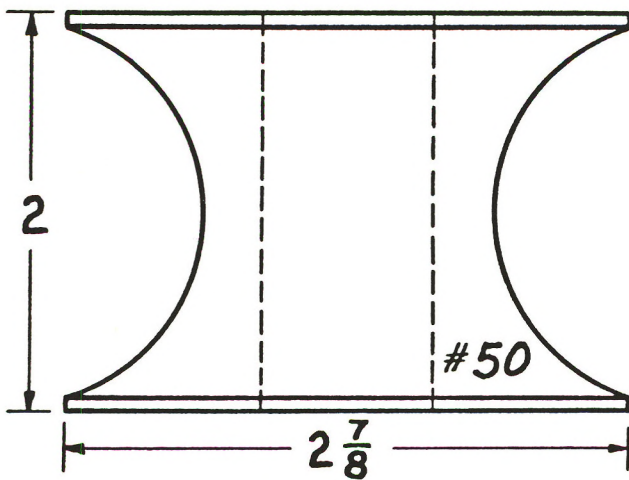
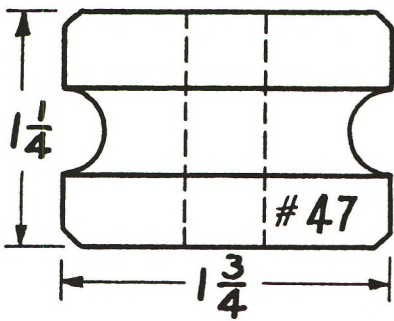
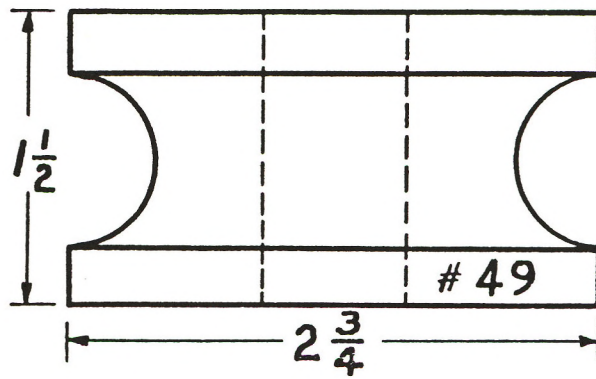
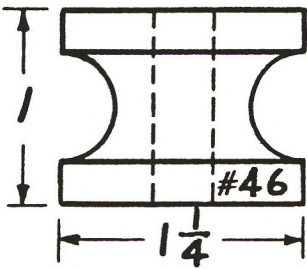
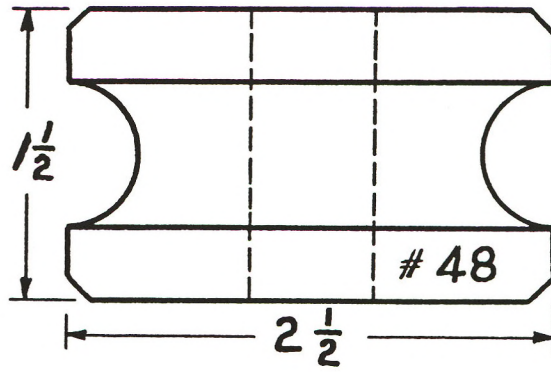
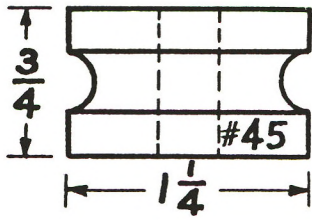

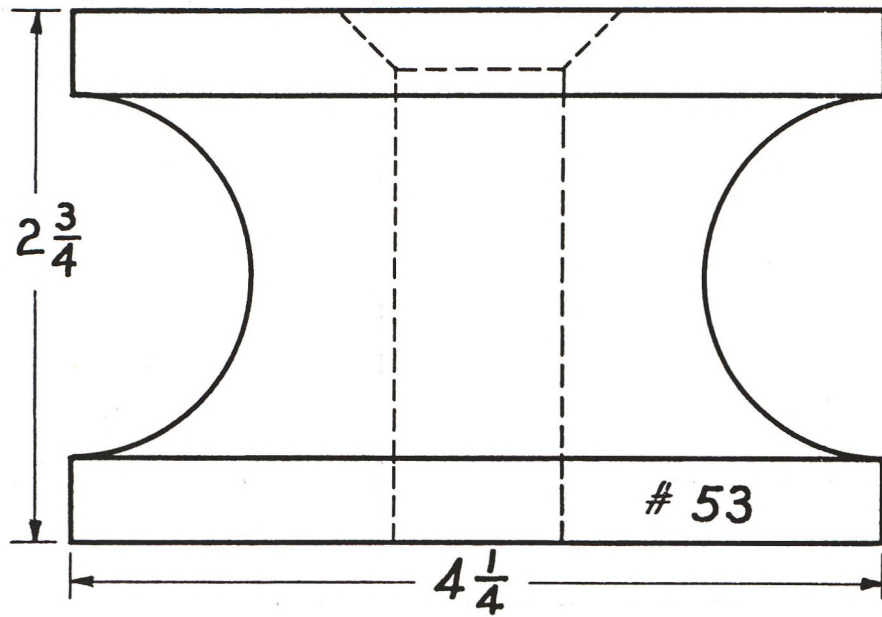
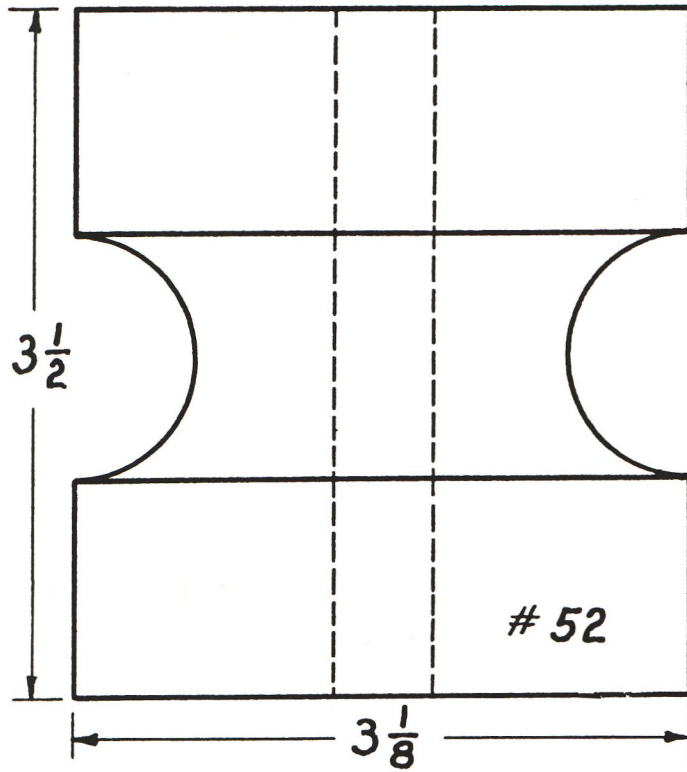

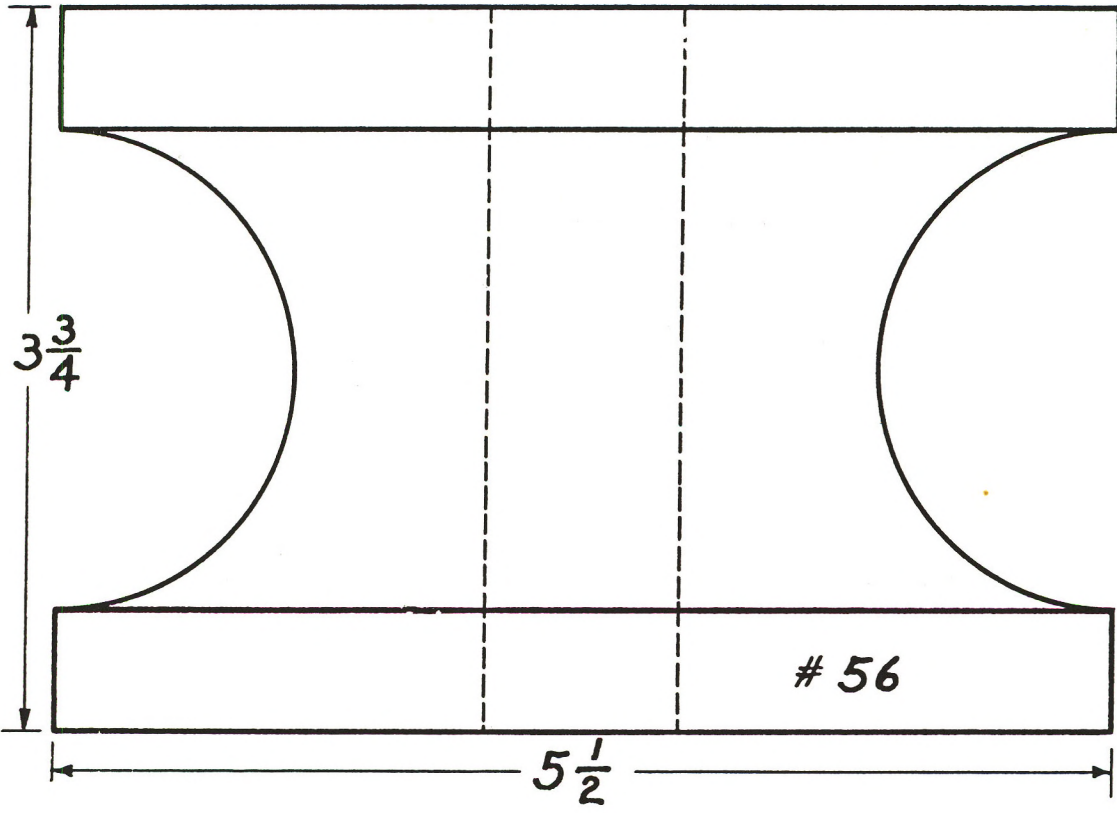
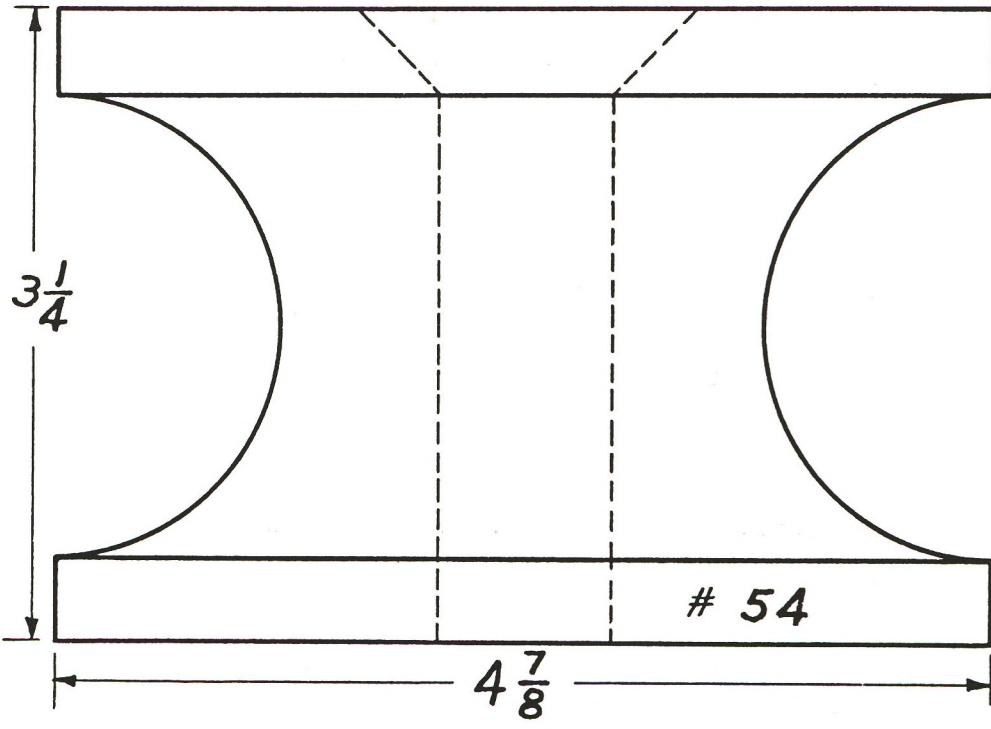

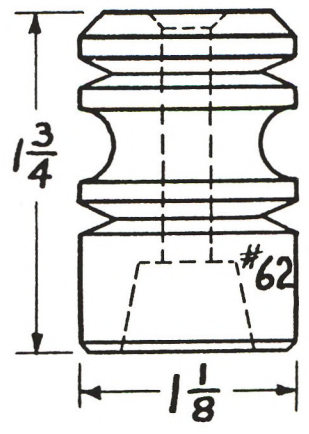
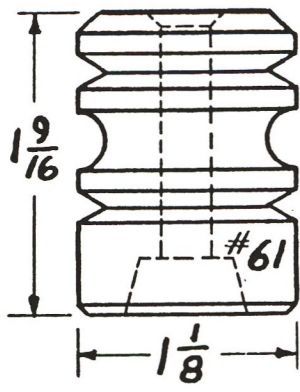
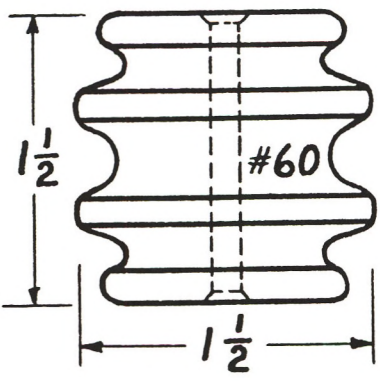
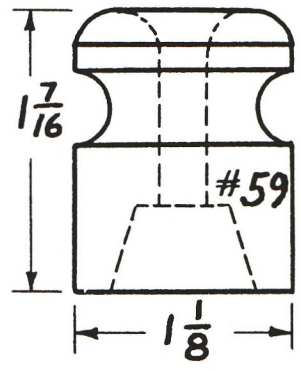
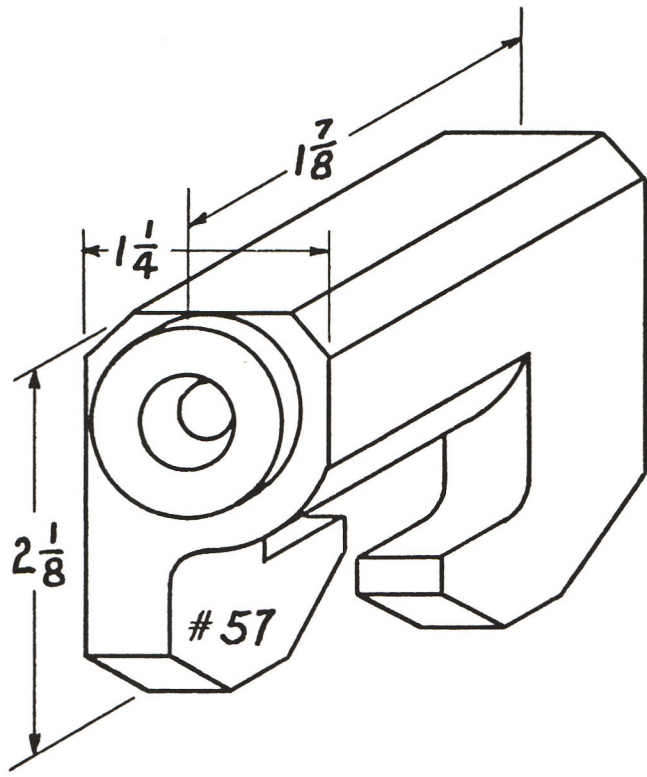
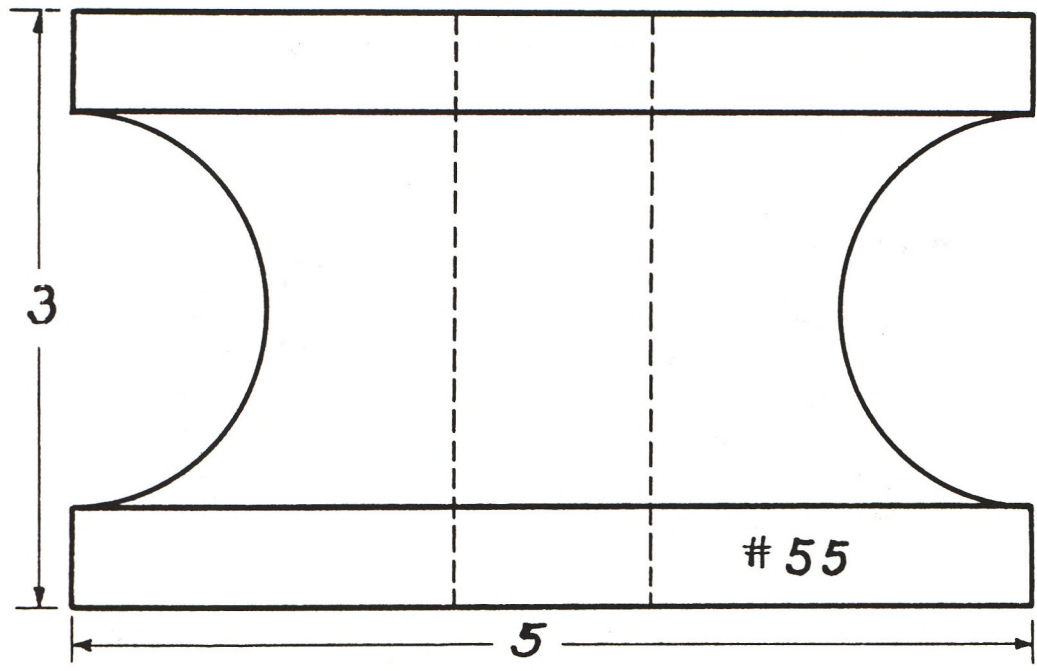

Economic Wiring Insulators.

Patented Oct. 4, 1892.

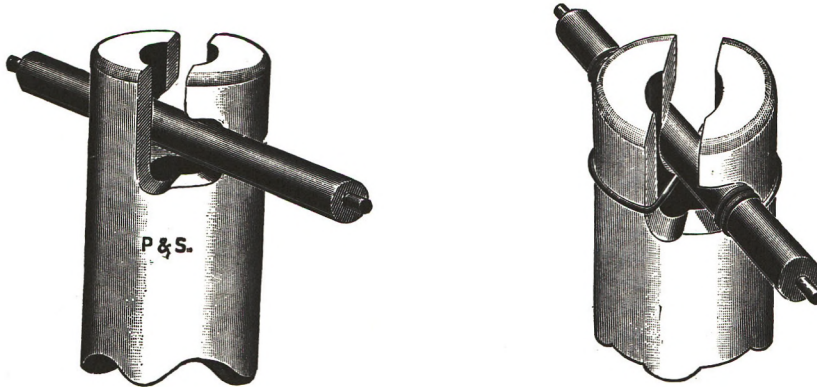

FOR a simple and convenient insulator for rapid wiring this is unsurpassed. They are low in price and of great strength. We also make the larger size with V-shaped groove in bottom, so as to adapt it to corner work.

P. & S. No. 01, for No. 1 wire and smaller, glazed Weight per 1000, 260 lbs.
 P. & S. No. 02, for No. 6 “ “ “ “ “ “ 1000, 80 lbs.

Porcelain Cleats, Two and Three-Wire.

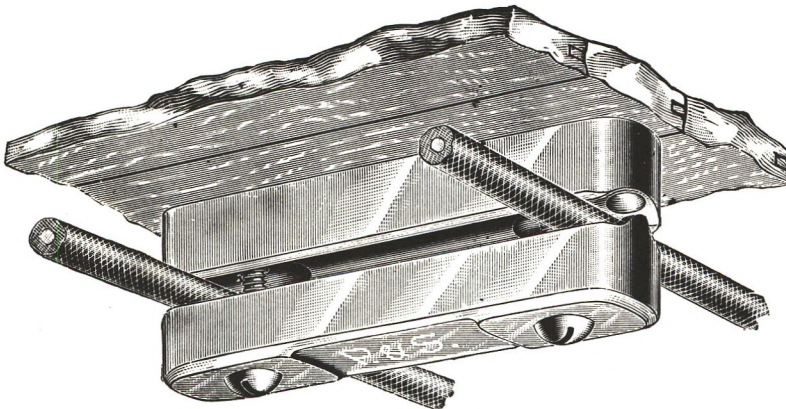

OUR cleats embody the best points in cleat construction. They are the strongest known, and the most convenient to use. The unglazed has as high insulating qualities as the glazed.

The large cleats will clamp tightly as heavy as No. 6 wire; the small cleats are designed for any size up to No. 10. They are packed in pasteboard boxes of 50 pairs.

PATENTED JUNE 14, 1892.

P. & S. No. 03	(Small) Glazed, Two wire.	Weight per 1000	163 lbs.
“ “ 03 1-2	“ Unglazed, “ “ “ “	“ “ “ “	163 “
“ “ 3	(Large) Glazed “ “ “ “	“ “ “ “	210 “
“ “ 3 1-2	“ Unglazed, “ “ “ “	“ “ “ “	210 “
“ “ 043	(Small) Glazed, Three “ “ “ “	“ “ “ “	163 “
“ “ 043 1-2	“ Unglazed, “ “ “ “	“ “ “ “	163 “
“ “ 43	(Large) Glazed, “ “ “ “	“ “ “ “	210 “
“ “ 43 1-2	“ Unglazed “ “ “ “	“ “ “ “	210 “
Standard Packages, 03, 03 1-2, 043, 043 1-2, Box contains 500, Bbl. contains 2300				
“ “ 3, 3 1-2, 43, 43 1-2, “ “ 500, “ “ 1750				

ASSEMBLED KNOBS

**ALLIGATOR
NAIL KNOB
SPLIT**

Glazed or Unglazed

Height1 3/4"
 Diameter1 1/8"
 Wire size12-14
 Standard containers:
 Carton quantity100
 Drum quantity2700
 Weight Per M.....165 lbs.

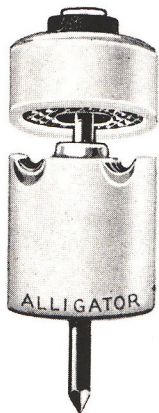

**ALLIGATOR
SCREW KNOB
SPLIT**

Glazed or Unglazed

Height1 3/4"
 Diameter1 1/8"
 Wire size12-14
 Standard containers:
 Carton quantity500
 Drum quantity2600
 Weight Per M165 lbs.



**NO. 5 1/2 SOLID
NAIL KNOB**

Glazed

Height1 3/4"
 Diameter1 1/8"
 Wire size12-14
 Standard containers:
 Carton quantity500
 Drum quantity3160
 Weight Per M150 lbs.



**NO. 5 1/2 SOLID
SCREW KNOB**

Glazed

Height1 3/4"
 Diameter1 1/8"
 Wire size12-14
 Standard containers:
 Carton quantity500
 Drum quantity3000
 Weight Per M150 lbs.



**GENERAL INFORMATION
ABOUT ASSEMBLED KNOBS**

Split knobs are either glazed or unglazed as specified by the customer. Glazed knobs cost more than unglazed. For 99% of concealed wiring, unglazed are perfectly satisfactory. Solid knobs are always glazed, which is standard.

Nails are 12d, with leather washers under head to absorb hammer blows, and with forced-fit steel washers at bottom of nail to keep insulator assembled while handling. Screws are #10 x 3" standard wood screws, cadmium plated, with fiber washers at bottom to keep assembly together.

Knobs shown on this page can be assembled with special nails or screws—prices upon request. Most split and solid knobs shown elsewhere in this catalog can also be supplied assembled with nails or screws. Tell us your requirements.



HYDRAULIC PRESSES

Automatic hydraulic presses assures uniform density and high mechanical-electrical characteristics.

SPLIT KNOBS UNASSEMBLED

NO. 5½ SPLIT KNOB

Glazed or Unglazed
 Height1¾"
 Diameter1½"
 Hole dia.¼"
 Std. containers:
 Carton quantity500
 Drum quantity3700
 Wgt. Per M 135 lbs.

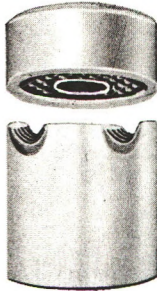

NO. 1916 "BUCK EYE" SPLIT KNOB

Glazed
 Height1¾"
 Diameter1¼"
 Hole dia.¼"
 Wire size12-14
 Std. containers:
 Carton quantity250
 Drum quantity2500
 Wgt. Per M. 180 lbs.

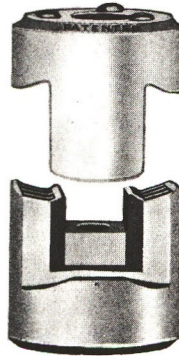

NO. 9417 SPLIT KNOB

Glazed
 Height1¾"
 Diameter1½"
 Hole dia.¼"
 Wire size12-14
 Std. containers:
 Carton quantity500
 Wgt. Per M 135 lbs.



NO. 9419 SPLIT KNOB

Glazed
 Height1⅞"
 Diameter1½"
 Hole diameter⅞"
 Wire size8-10
 Standard containers:
 Carton quantity250
 Weight Per M248 lbs.



NO. 1917 "DETROIT" SPLIT KNOB

Glazed
 Height1⅞"
 Diameter1¼"
 Hole diameter¼"
 Wire size12-14
 Standard containers:
 Carton quantity250
 Drum quantity2500
 Weight Per M180 lbs.

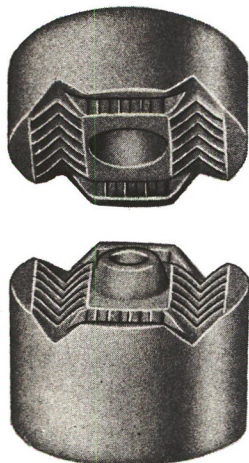

NO. 9420 SPLIT KNOB

Glazed
 Height2⅞"
 Diameter2"
 Hole diameter⅞"
 Wire size4-6
 Standard containers:
 Carton quantity100
 Weight Per M540



"PARAGON SELF-TYING" SPLIT KNOB

Glazed
 Over-all height2⅞"
 Base diameter1⅝"
 Base height1⅞"
 Cap diameter1⅞"
 Hole diameter11/32"
 Standard containers:
 Carton quantity100
 Weight Per M492 lbs.

FORESTRY INSULATORS **SPLIT KNOBS**

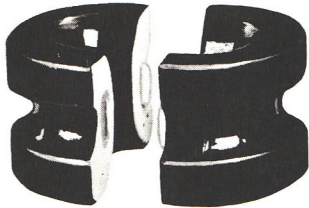

**NO. 6539
ROUND SPLIT
U. S. No. D-5
Glazed**

Height1½"
Diameter2¼"
Hole1½" x 1½"
Wire groove diameter½"
Standard container100
Weight Per M430 lbs.

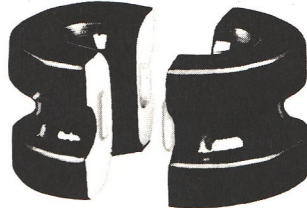

**NO. 6572
ROUND SPLIT
U. S. No. D-2
Glazed**

Height1½"
Diameter2¼"
Hole7/8" x ½"
Wire groove diameter½"
Standard container100
Weight Per M430

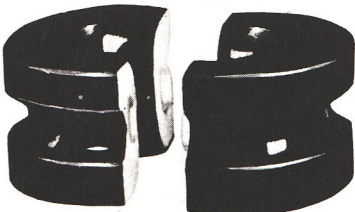

**NO. 6651
OVAL SPLIT
U. S. No. D-1
Glazed**

Height1½"
Length3"
Width2¼"
Hole¾" x 1¼"
Wire groove diameter½"
Standard container100
Weight Per M560



**No. 6844
OVAL SOLID
U.S. No. D-6
Glazed**

Height1½"
Length3"
Width2¼"
Hole¾" x 1¼"
Wire groove diameter½"
Standard container100
Weight Per M560

**NO. 6147 FORESTRY KNOB
(No. 37 Split)
(Glazed)**

Height1½"
Diameter1¾"
Hole diameter½"
Wire groove diameter½"
Standard containers:
Carton quantity200
Drum quantity1650
Weight Per M264 lbs.

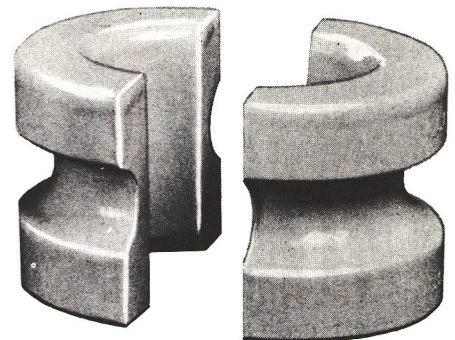
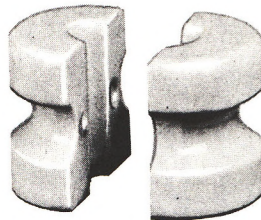

**NO. 38 SPLIT KNOB
Glazed**

Height2¼"
Diameter3"
Hole diameter1½"
Wire groove diameter¾"
Standard containers:
Carton quantity75
Drum quantity350
Weight Per M986 lbs.

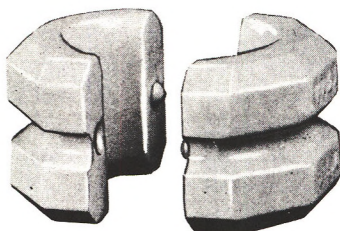

**NO. 22
"VICTOR"
SPLIT KNOB
Glazed**

Height1¾"
Diameter2⅞"
Hole diameter1"
Wire groove diameter5/8"
Standard containers:
Carton quantity100
Drum quantity1100
Weight Per M400 lbs.

PORCELAIN TUBES

STANDARD UNGLAZED TUBES

LIST PRICES PER 1000

In Ordering, Specify **INSIDE DIAMETER**
and **LENGTH UNDER HEAD.**



Listed as standard by Underwriters'
Laboratories' Re-examination Service

Length	5/16" ID, 9/16" OD		3/8" ID, 11/16" OD		1/2" ID, 13/16" OD		5/8" ID, 15/16" OD	
	Weight per M	Price per M	Weight per M	Price per M	Weight per M	Price per M	Weight per M	Price per M
1/2	26	\$ 17.60	30	\$ 22.00	\$	\$
1	32	18.70	37	23.10	56	29.70	78	44.00
1 1/2	40	19.80	48	24.20	74	30.80	97	50.60
2	45	20.90	54	26.40	86	33.00	112	57.20
2 1/2	58	23.10	76	29.70	100	36.30	127	63.80
3	62	25.30	107	33.00	114	40.70	135	71.50
4	80	33.00	117	44.00	138	52.80	149	88.00
5	100	42.90	142	55.00	169	66.00	155	104.00
6	118	55.00	183	66.00	204	79.20	226	121.00
8	155	99.00	225	115.00	255	143.00	294	154.00
10	194	184.00	275	205.00	311	236.00	364	275.00
12	244	268.00	350	294.00	344	330.00	400	374.00
14	333	353.00	400	383.00	393	424.00	444	473.00
16	387	438.00	483	472.00	500	517.00	500	572.00
18	435	522.00	580	561.00	589	610.00	571	671.00
20	485	607.00	644	650.00	662	704.00	700	770.00
24	535	777.00	725	828.00	757	891.00	800	968.00

Length	1-3/4" ID, 2-9/16" OD		2" ID, 2-15/16" OD	2-1/4" ID, 3-5/16" OD	2-1/2" ID, 3-11/16" OD	2-3/4" ID, 4-1/4" OD	3" ID, 4-1/2" OD
	Weight per M	Price per M	Price per M	Price per M	Price per M	Price per M	Price per M
2	760	\$341.00	\$462.00	\$	\$	\$	\$
2 1/2	982	374.00	506.00	649.00	814.00	1020.00	1270.00
3	1080	407.00	550.00	704.00	880.00	1100.00	1370.00
4	1156	490.00	693.00	920.00	1200.00	1600.00	1920.00
5	1500	572.00	836.00	1140.00	1520.00	2090.00	2480.00
6	1714	660.00	990.00	1350.00	1840.00	2590.00	3030.00
8	1917	825.00	1280.00	1780.00	2480.00	3570.00	4130.00
10	2300	990.00	1580.00	2200.00	3120.00	4570.00	5230.00
12	2556	1760.00	1870.00	2640.00	3770.00	5560.00	6320.00
14	3067	2090.00	3080.00	4400.00	6160.00	6550.00	7480.00
16	4182	2420.00	3520.00	4970.00	6870.00	9020.00	11200.00
18	5111	2750.00	3960.00	5540.00	7570.00	9790.00	12300.00
20	5500	3080.00	4400.00	6120.00	8270.00	10600.00	13300.00
24	5750	3740.00	5280.00	7260.00	9680.00	12100.00	15400.00

Length	3/4" ID, 1-3/16" OD		1" ID, 1-7/16" OD		1-1/4" ID, 1-13/16" OD		1-1/2" ID, 2-3/16" OD	
	Weight per M	Price per M	Weight per M	Price per M	Weight per M	Price per M	Weight per M	Price per M
1	93	\$ 66.00	140	\$110.00	\$	\$
1 1/2	127	77.00	193	123.00	430	165.00	660	231.00
2	159	88.00	260	137.00	510	187.00	730	253.00
2 1/2	193	99.00	325	152.00	578	209.00	815	281.00
3	217	110.00	385	165.00	650	231.00	883	308.00
4	250	128.00	436	185.00	714	264.00	1020	352.00
5	339	145.00	440	205.00	768	299.00	1306	396.00
6	373	163.00	489	225.00	836	337.00	1407	446.00
8	444	198.00	525	265.00	1000	414.00	1607	539.00
10	667	319.00	750	413.00	1100	495.00	1875	638.00
12	800	429.00	955	550.00	1375	770.00	2250	1130.00
14	900	541.00	1167	688.00	1833	957.00	2812	1360.00
16	1000	653.00	1312	825.00	2200	1150.00	3750	1590.00
18	1100	766.00	1400	963.00	2750	1330.00	4500	1830.00
20	1200	878.00	1750	1100.00	3200	1520.00	4800	2060.00
24	1334	1100.00	2100	1375.00	3667	1900.00	5000	2530.00

SPECIAL TUBES

For list prices on Split Tubes, Crossover Tubes, Split Cross-over Tubes, Curved Tubes, Curved End Tubes, Floor Tubes and Glazed Tubes see below:

For glazed tubes add fifty percent.

For split regular tubes, multiply list by ten. Measurements under head.

For solid cross-over tubes multiply list by six. Measurements between heads.

For split cross-over tubes, multiply list by twelve. Measurements between heads.

For solid floor tubes, multiply list by three. Heads, three inches long. Measurements under heads.

For split floor tubes, multiply list by six. Heads, three inches long. Measurements under head.

For curved tubes, multiply list by three. Measurements over all.

For curved end tubes, multiply list by three. Heads, three inches long. Measurements overall.

For headless tubes above eight inches long, multiply list by four. Tubes eight inches long or under take standard list. Measurements overall.

Each multiplier applies only to LIST PRICE, without pyramiding.

CAREY, OHIO

PORCELAIN PRODUCTS, INC.

STANDARD TWO AND THREE WIRE CLEATS

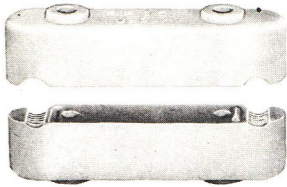

No. 335 2-Wire

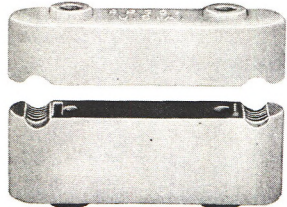

No. 335A 2-Wire

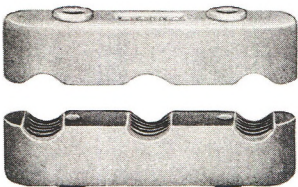

No. 336 3-Wire

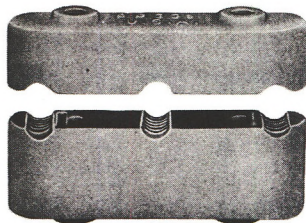

No. 336A 3-Wire

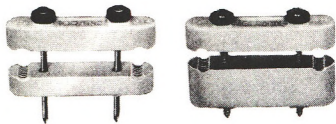

Nail Assembled Screw Assembled

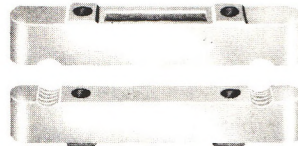

No. 334 2-Wire

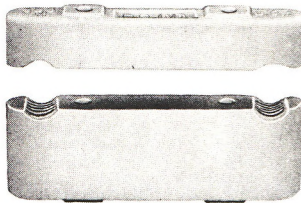

No. 334A 2-Wire

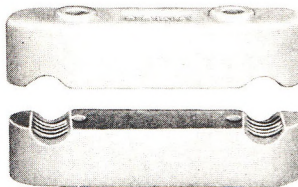

No. 350 2-Wire

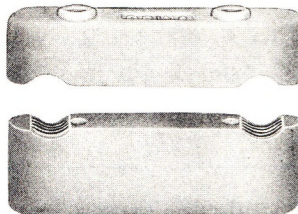

No. 350A 2-Wire

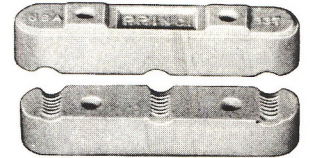

No. 337 3-Wire

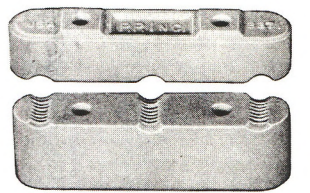

No. 337A 3-Wire

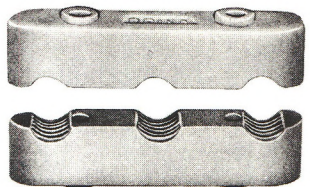

No. 351 3-Wire

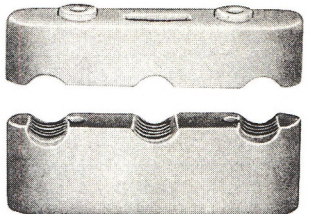

No. 351A 3-Wire

NAIL OR SCREW ASSEMBLY

Any of the 2 or 3 wire cleats shown on this page can be shipped with nails or screws assembled in the cleats as illustrated at left. Saves time over site assembly, speeds construction.

Catalog Number		† Wire Size	Width Inches	Length Inches	Height, Inches		Diam Nail Hole	Std. Pkg.	Wt. Per M.
2-Wire	3-Wire				* Cap	* Base			
334	337	12-14	11/16	3-1/2	1/2	1/2	15/64	200	250 lbs.
334-A	337-A	12-14	11/16	3-1/2	1/2	1	15/64	200	300 lbs.
335	336	12-14	3/4	3-7/16	11/16	11/16	15/64	250	284 lbs.
335-A	336-A	12-14	3/4	3-7/16	11/16	1	15/64	250	375 lbs.
350	351	8-10	3/4	3-5/8	11/16	5/8	15/64	250	315 lbs.
350-A	351-A	8-10	3/4	3-5/8	11/16	1	15/64	250	375 lbs.

† Type R, Rubber Covered

* Measured from bottom of wire groove

WIRE SPACING—Two wire cleats provide a wire spacing of 2 1/2". Three wire cleats provide a wire spacing of 1 1/4".

B. & D. CLEATS ONE-WIRE GLAZED

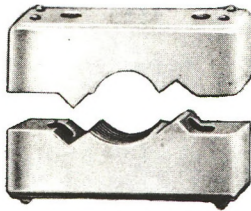

Style R

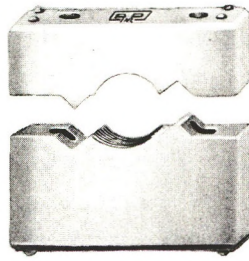

Style A

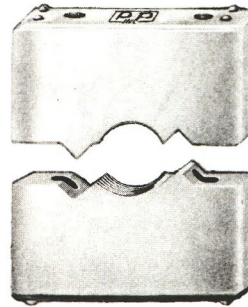

Style B

STYLE R—Light Cap, Light Base

Cat. No.	Length	Width	Min. Height Cleat Closed	Bolt Hole Spacing	Bolt Hole Dia.	Bolt Dia.	Wood Screw No.	Diam. Wire Accommodated		Type R* Wire Size	Standard Carton	Sh. Wt. per M. Pr.
								Min.	Max.			
1-R	2	3/4	1-3/8	1-7/32	1/4	3/16	10	3/16	1/2	14-2	250	184
1 1/2-R	2-1/4	7/8	1-1/2	1-1/2	5/16	1/4	14	3/8	9/16	6-1	250	216
2-R	2-1/4	1-1/16	1-5/8	1-13/32	5/16	1/4	14	7/16	11/16	4-00	200	355
2 1/2-R	2-13/16	1-1/4	2-1/8	1-5/8	5/16	1/4	14	7/16	3/4	4-0000	100	610
3-R	3-1/8	1-1/4	2-1/8	1-29/32	3/8	5/16	18	1/2	1	2-400M	100	700

STYLE A—Light Cap, Heavy Base

1-A	2	3/4	1-13/16	1-7/32	1/4	3/16	10	3/16	1/2	14-2	200	250
1 1/2-A	2-1/4	7/8	1-15/16	1-1/2	5/16	1/4	14	3/8	9/16	6-1	100	310
2-A	2-1/4	1-1/16	2-1/16	1-13/32	5/16	1/4	14	7/16	11/16	4-00	150	393
2 1/2-A	2-13/16	1-1/4	2-5/16	1-5/8	5/16	1/4	14	7/16	3/4	4-0000	100	730
3-A	3-1/8	1-1/4	2-5/16	1-29/32	3/8	5/16	18	1/2	1	2-400M	100	800

STYLE B—Heavy Cap, Heavy Base

1-B	2	3/4	2-1/4	1-7/32	1/4	3/16	10	3/16	1/2	14-2	200	305
1 1/2-B	2-1/4	7/8	2-3/8	1-1/2	5/16	1/4	14	3/8	9/16	6-1	100	390
2-B	2-1/4	1-1/16	2-1/2	1-13/32	5/16	1/4	14	7/16	11/16	4-00	100	510
2 1/2-B	2-13/16	1-1/4	2-1/2	1-5/8	5/16	1/4	14	7/16	3/4	4-0000	100	720
3-B	3-1/8	1-1/4	2-1/2	1-29/32	3/8	5/16	18	1/2	1	2-400M	50	880
3 1/2-B	3-1/8	1-1/4	2-3/4	2-1/4	3/8	5/16	18			#10 Dup. Par'l.		
4-B	3-5/8	1-5/16	3-1/8	2-13/32	3/8	5/16	18	3/4	1-1/4	0000-700M	50	1000
4 1/4-B	5	1-15/16	3-1/2	3-5/16	9/16	1/2	24	1-1/8	1-3/8	600M-900M	50	1180
4 1/2-B	5-5/16	2	3-5/8	3-11/16	9/16	1/2	24	1-5/16	1-5/8	800M-1250M		
								1-15/32	2-1/4	1MM-2MM	25	3080

*For other than Type R wire size check dimensions.
 Style R has wire grooves 1/2 inch from surface of both cap and base.
 Style A has wire grooves 1 inch from surface of base and 1/2 inch from surface of cap.
 Style B has wire grooves 1 inch from surface of both cap and base.

SOLID KNOBS

No. 00
 Standard package
 quantity75
 Weight Per M.....
 1150 lbs.

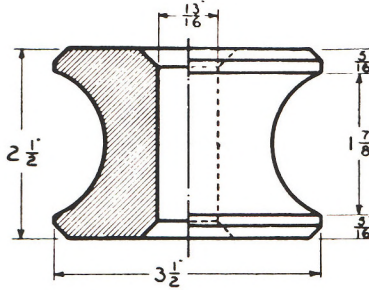

No. 3
 Standard package
 quantity100
 Weight Per M530 lbs.

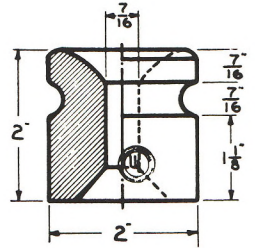

No. 0
 Standard package
 quantity50
 Weight Per M 960 lbs.

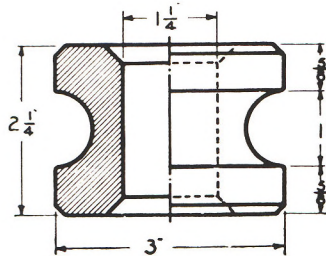

No. 3 1/2
 Standard Package
 quantity100
 Weight Per M.....460 lbs.

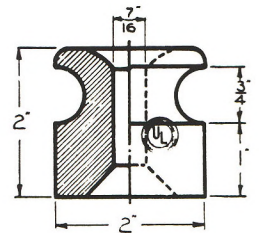

No. 1
 Standard package quantity 75
 Weight Per M800 lbs.

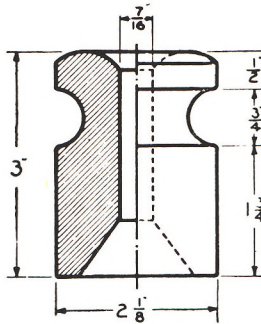

No. 4
 Standard package quantity 250
 Weight Per M216 lbs.

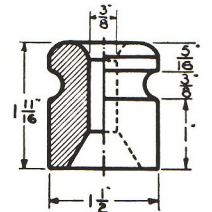

No. 2
 Standard package quantity 100
 Weight Per M500 lbs.

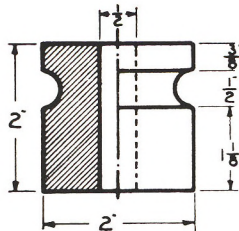

No. 4 1/2
 Standard package quantity 250
 Weight Per M200 lbs.

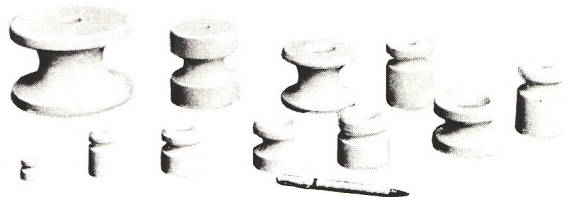
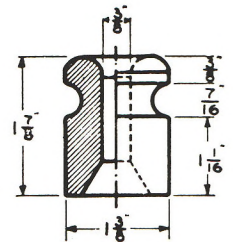

Spools of all sizes to fit all needs.

SOLID KNOBS

No. 5
 Standard package
 quantity500
 Weight Per M72 lbs.

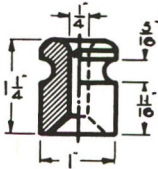

No. 9 1/2
 Standard package
 quantity2000
 Weight Per M16 lbs.

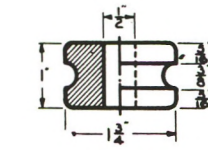

No. 16
 Standard package
 quantity250
 Weight Per M 210 lbs.

No. 5 1/2
 Standard package
 quantity500
 Weight Per M130 lbs.

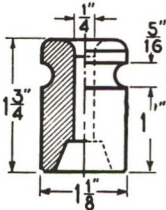

No. 10
 Standard package
 quantity250
 Weight Per M230 lbs.

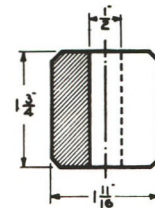
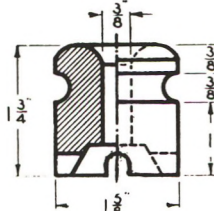

No. 17
 Standard package
 quantity100
 Weight Per M 420 lbs.

No. 6
 Standard package
 quantity2000
 Weight Per M34 lbs.

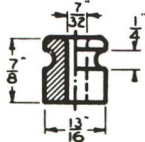

No. 11
 Standard package
 quantity500
 Weight Per M45 lbs.

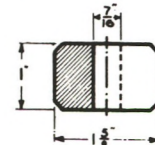
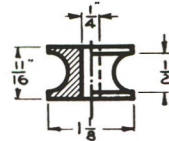

No. 18
 Standard package
 quantity500
 Weight Per M 180 lbs.

No. 7
 Standard package
 quantity2000
 Weight Per M28 lbs.

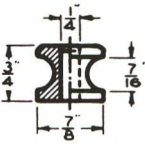

No. 12
 Standard package
 quantity250
 Weight Per M55 lbs.

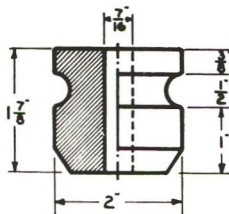
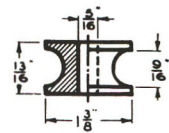

No. 19
 Std. package quantity...100
 Weight Per M.....470 lbs.

No. 7A
 Standard package
 quantity2000
 Weight Per M30 lbs.

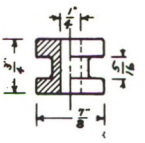

No. 13
 Standard package
 quantity250
 Weight Per M52 lbs.

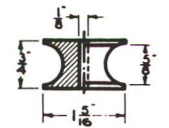

No. 8
 Standard package
 quantity2000
 Weight Per M50 lbs.

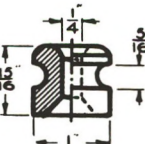

No. 14
 Standard package
 quantity200
 Weight Per M32 lbs.

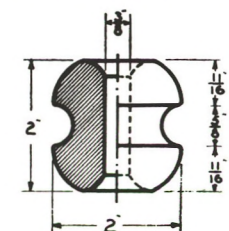
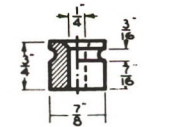

No. 20
 Std. package quantity...100
 Weight Per M.....410 lbs.

No. 9
 Standard package
 quantity2000
 Weight Per M27 lbs.

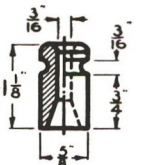

No. 15
 Standard package
 quantity200
 Weight Per M265 lbs.

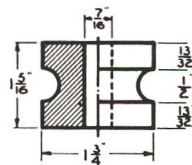

SOLID KNOBS

No. 21
 Standard package
 quantity75
 Weight Per M.....
 700 lbs.

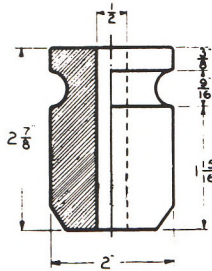

No. 26
 Standard package
 quantity100
 Weight Per M.....
 570 lbs.

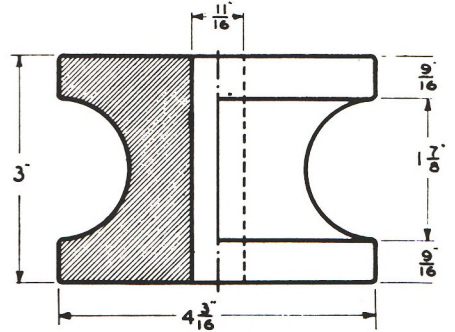
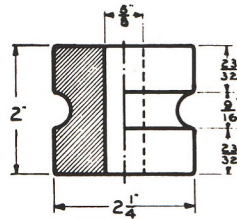

No. 32
 Standard package
 quantity25
 Weight Per M2400 lbs.

No. 22
 Standard package
 quantity100
 Weight Per M.....
 400 lbs.

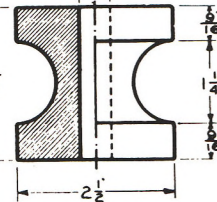
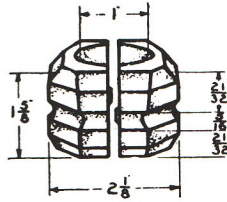

No. 29
 Standard package
 quantity100
 Weight Per M.....
 580 lbs.

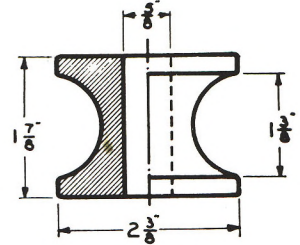

No. 34
 Standard Package
 quantity100
 Weight Per M.....
 420 lbs.

No. 23
 Standard package
 quantity500
 Weight Per M 134 lbs.

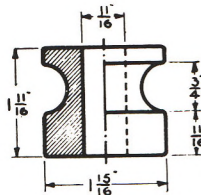
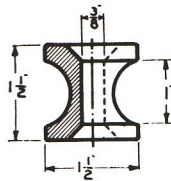

No. 30
 Standard package
 quantity100
 Weight Per M 430 lbs.

No. 35
 Standard package
 quantity200
 Weight Per M26 lbs.

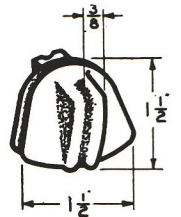

No. 24
 Standard package
 quantity100
 Weight Per M 380 lbs.

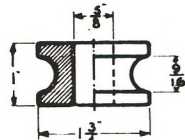
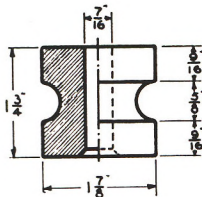

No. 31
 Standard package
 quantity250
 Weight Per M 210 lbs.

No. 36
 Standard package
 quantity250
 Weight Per M240 lbs.

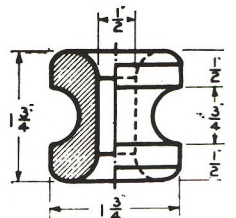

No. 25
 Standard package
 quantity100
 Weight Per M.....
 420 lbs.

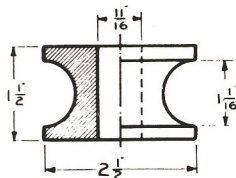

SOLID KNOBS

**No. 37 SPLIT
(No. 6147)**
Standard package
quantity200
Weight Per M.....264 lbs.

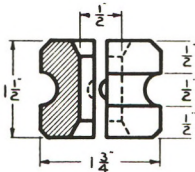

No. 49
Standard pack-
age quantity 100
Weight Per M
620 lbs.

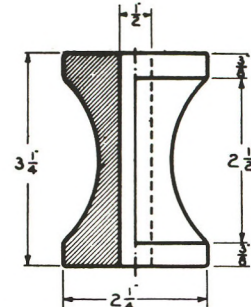
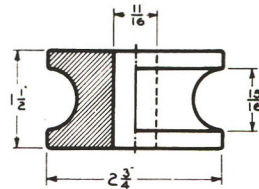

No. 37
Standard package
quantity200
Weight Per M.....270 lbs.

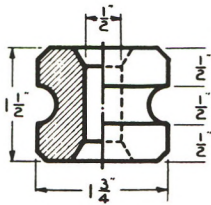

No. 50
Standard pack-
age quantity 75
Weight Per M
800 lbs.

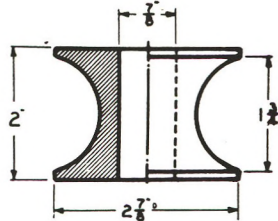

No. 51
Standard pack-
age Quantity 100
Weight Per M
667 lbs.

No. 39
Standard package
quantity100
Weight Per M 485 lbs.

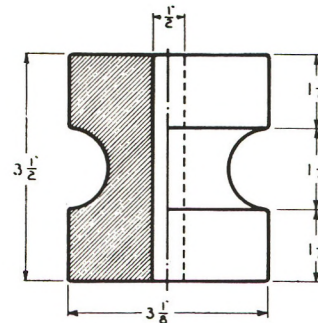
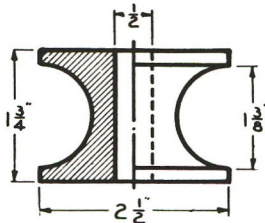

No. 52
Standard package
quantity25
Weight Per M 2000 lbs.

No. 45
Standard package
quantity500
Weight Per M68 lbs.

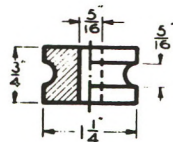

No. 46
Standard package
quantity500
Weight Per M64 lbs.

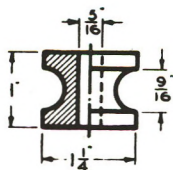

No. 47
Standard package
quantity250
Weight Per M 210 lbs.

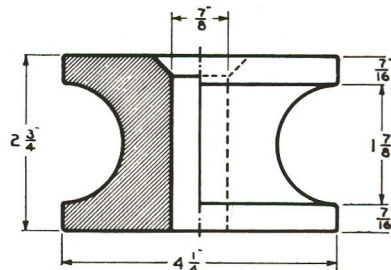
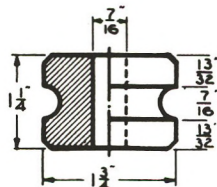

No. 53
Standard package
quantity25
Weight Per M 2700 lbs.

SOLID KNOBS

No. 55
 Standard package
 quantity10
 Weight Per M 4000 lbs.

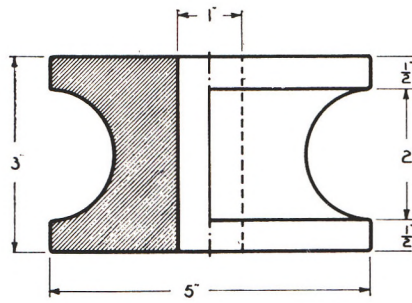

No. 56
 Standard package
 quantity10
 Weight Per M 5350 lbs.

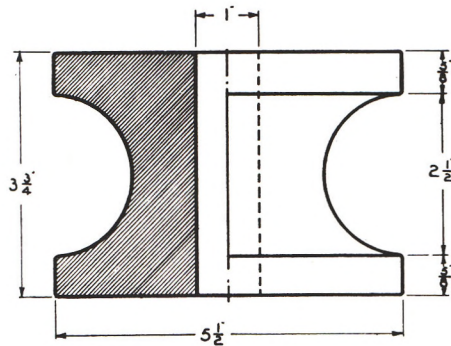

No. 57
 Standard package
 quantity200
 Weight Per M...250 lbs.

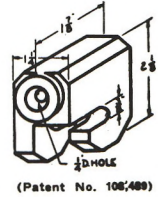

No. 59
 Standard package
 quantity500
 Weight Per M...94 lbs.

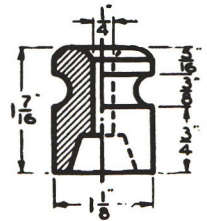

No. 60
 Standard package
 quantity250
 Weight Per M...188 lbs.

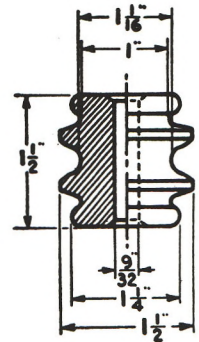

No. 61
 Standard package
 quantity500
 Weight Per M...100 lbs.

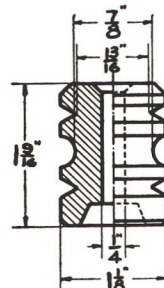

No. 62
 Standard package
 quantity500
 Weight Per M...120 lbs.

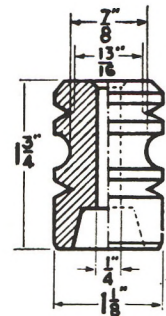

TURNING MACHINE

Automatic precision turning of knobs for uniformity—each knob is exactly like the others as a result of quality control.

SPECIAL PORCELAIN

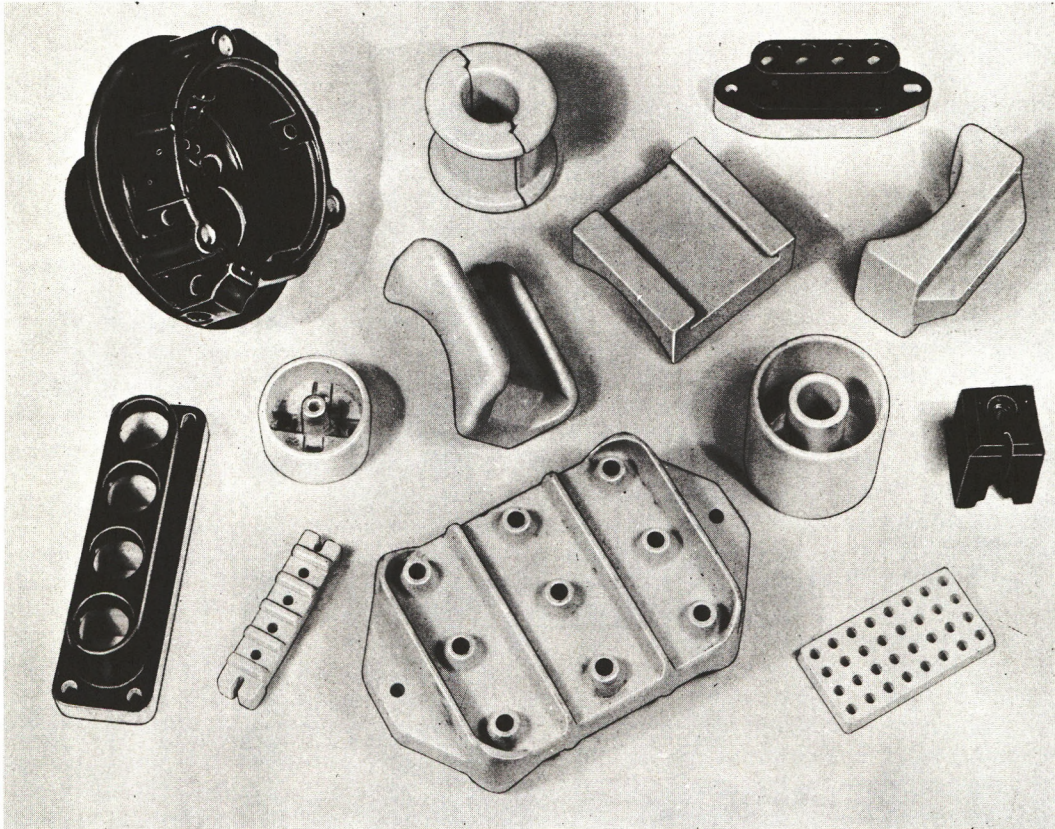

Porcelain Products, Inc., is always happy to furnish quotations on porcelain pieces formed to the customer's individual specifications. Our engineering staff is at your disposal to help in the design. Die charges are modest and delivery is prompt.

DESIGN HINTS: When designing a piece to be made of porcelain there are a few things you should know to help keep your cost down, though, of course our engineers will always make cost saving recommendations.

(1) For standard low-voltage applications (up to 600 V.) porcelain made of the dry process method is usually entirely satisfactory and most economical.

(2) Dry process porcelain is formed by the compacting of granulated materials. The design should therefore incorporate draft to facilitate removal of the piece from the die, and it should be possible to

form the piece by pressing in one direction only. More complicated designs can be made, of course, but will cost more.

(3) Porcelain can also be extruded in just about any cross section, such as rod, tube, etc.

(4) On pressed pieces $\pm 1/64''$ tolerance is requested in the direction of pressing.

(5) Wall thicknesses should be as great as possible, which will help reduce your cost.

(6) Glazed pieces cost more than unglazed. White and brown are standard colors and therefore most economical. One surface, on which the piece rests while being fired, must be left unglazed.

(7) Special clay bodies can be prepared to yield to the porcelain desired properties, such as high absorption, high refractoriness, etc.

Standard Porcelain Telephone Knobs

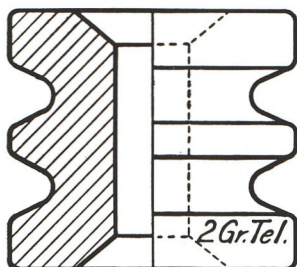

No. M6061

Stock No.....	M6061
Type.....	2 Gr.
Height.....inches	1 ¹ / ₁₆
Diameter.....inches	1 ⁵ / ₈
Diameter Hole.....inches	1 ³ / ₃₂
Diameter Groove.....inches	5 ¹ / ₁₆
No. per Barrel.....	1900
Wt. per 1000.....pounds	210

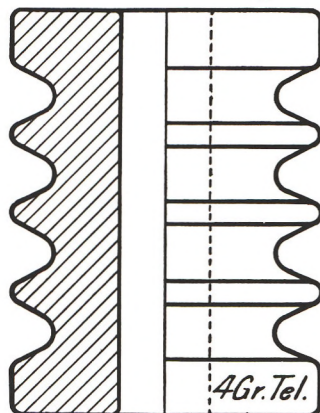

No. M6062

Stock No.....	M6062
Type.....	4 Gr.
Height.....inches	2 ¹ / ₄
Diameter.....inches	1 ³ / ₄
Diameter Hole.....inches	7 ¹ / ₁₆
Diameter Groove.....inches	5 ¹ / ₁₆
No. per Barrel.....	1000
Wt. per 1000.....pounds	395

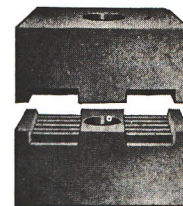

No. M7137C

Stock No.....	M7137C
Type.....	Cleat
Height.....inches	3 ¹ / ₄
Diameter.....inches	3 ¹ / ₄ x 1 ¹³ / ₁₆
Diameter Hole.....inches	7 ¹ / ₃₂
Diameter Groove.....inches	5 ¹ / ₁₆
No. per Barrel.....	5000
Wt. per 1000.....pounds	92

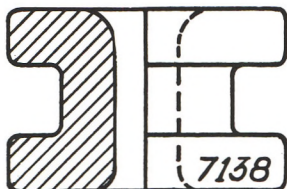

No. M7138

Stock No.....	M7138
Type.....	1 Gr.
Height.....in.	1 ¹ / ₁₆
Diameter.....in.	1 ⁵ / ₈
Diam. Hole.....in.	3 ³ / ₈
Diam. Groove.....in.	1 ¹³ / ₃₂
No. per Barrel.....	2500
Wt. per 1000...lbs.	150

Stock No.....	M7139
Type.....	2 Gr.
Height.....in.	1 ¹³ / ₁₆
Diameter.....in.	1 ⁵ / ₈
Diam. Hole.....in.	3 ³ / ₈
Diam. Groove.....in.	1 ¹³ / ₃₂
No. per Barrel...	1500
Wt. per 1000...lbs.	240

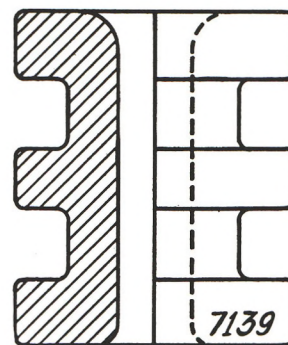

No. M7139

U.S. Forestry Porcelain Insulators

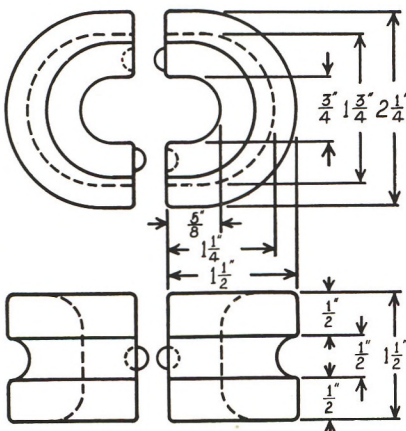

No. M6551
U. S. No. D1

Stock No.....	M6551
U.S. No.....	D1
No. per Barrel.....	700
Wt. per 1000.....pounds	580

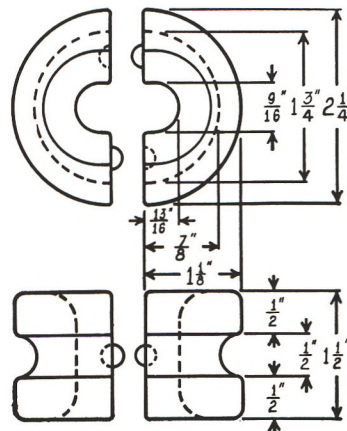

No. M6539
U. S. No. D2

Stock No.....	M6539
U.S. No.....	D2
No. per Barrel.....	1000
Wt. per 1000.....pounds	405

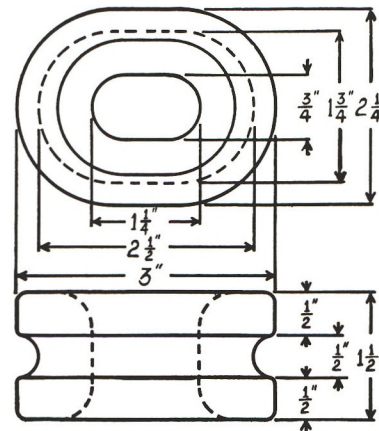

No. M6844
U. S. No. D6

Stock No.....	M6844
U.S. No.....	D6
No. per Barrel.....	700
Wt. per 1000.....pounds	580

STANDARD ELECTRIC PORCELAIN

Porcelain Cleats

Two Wire Cleats

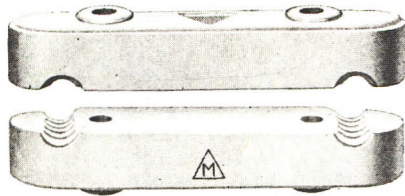

Three Wire Cleats

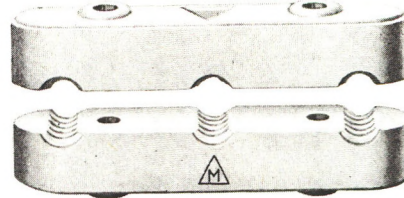

Stock No.	M336	M350
Height	1 1/8 inches	1 1/2 inches
Width	5/8 inches	3/4 inches
Length	3 5/16 inches	3 1/2 inches
Diameter Groove	3/32 to 1/4 inches	1/8 to 3/8 inches
Diameter Holes	1/4 inches	5/16 inches
No. per Barrel	2000	1200
Weight per 1000	200 pounds	333 pounds

Stock No.	M337	M351
Height	1 1/8 inches	1 1/2 inches
Width	5/8 inches	3/4 inches
Length	3 5/16 inches	3 1/2 inches
Diameter Groove	3/32 to 1/4 inches	1/8 to 3/8 inches
Diameter Holes	1/4 inches	5/16 inches
No. per Barrel	2000	1200
Weight per 1000	200 pounds	333 pounds

Standard One Wire Cleats

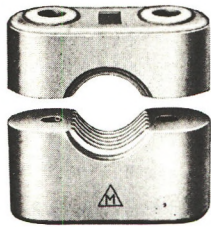

Stock No.	Size Wire	Groove Inches	Diameter Hole Inches	Length Inches	Width Inches	No. per Barrel	Weight Pounds per 1000
M1 Regular	14 to 8	3/32 to 3/8	1/4	2	7/8	2800	170
M2 Regular	8 to 4	3/8 to 1/2	1/4	2 1/4	1	1800	260
M3 Regular	4 to 0	1/2 to 5/8	1/4	2 1/2	1 1/8	1500	310
M4 Regular	0 to 0000	5/8 to 3/4	5/16	2 3/4	1 1/4	950	500
M5 Regular	0000 to 300,000 CM.	3/4 to 1	5/16	3	1 3/8	800	560
M1 A	14 to 8	3/32 to 3/8	1/4	2	7/8	2400	220
M2 A	8 to 4	3/8 to 1/2	1/4	2 1/4	1	1400	340
M3 A	4 to 0	1/2 to 5/8	1/4	2 1/2	1 1/8	1200	400
M4 A	0 to 0000	5/8 to 3/4	5/16	2 3/4	1 1/4	800	580
M5 A	0000 to 300,000 CM.	3/4 to 1	5/16	3	1 3/8	700	650
M1 B	14 to 8	3/32 to 3/8	1/4	2	7/8	1800	270
M2 B	8 to 4	3/8 to 1/2	1/4	2 1/4	1	1150	420
M3 B	4 to 0	1/2 to 5/8	1/4	2 1/2	1 1/8	1000	480
M4 B	0 to 0000	5/8 to 3/4	5/16	2 3/4	1 1/4	750	650
M5 B	0000 to 300,000 CM.	3/4 to 1	5/16	3	1 3/8	650	740
M6 B	300,000 to 550,000 CM.	1 to 1 1/4	3/8	3 3/8	1 1/2	450	1000
M7 B	550,000 to 1,000,000 CM.	1 1/4 to 1 1/2	3/8	3 3/4	1 5/8	375	1400
M8 B	1,000,000 to 2,000,000 CM.	1 1/2 to 1 3/4	7/16	4 1/2	1 3/4	250	2300
M9 B	1,500,000 to 2,000,000 CM.	1 3/4 to 2	7/16	5	2	200	2700

B. & D. One Wire Cleats

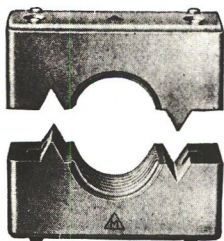

Stock No.	Size Wire	Groove Inches	Diameter Hole Inches	Length Inches	Width Inches	No. per Barrel	Weight Pounds per 1000
M1 Regular	14 to 10	3/32 to 1/4	1/4	1 3/4	3/4	2800	170
M2 Regular	10 to 6	1/4 to 3/8	1/4	1 7/8	7/8	1800	260
M3 Regular	6 to 2	3/8 to 1/2	5/16	2 1/4	1	1500	310
M4 Regular	2 to 00	1/2 to 5/8	5/16	2 1/2	1 1/8	950	500
M5 Regular	00 to 0000	5/8 to 13/16	3/8	2 13/16	1 1/4	800	560
M1 A	14 to 10	3/32 to 1/4	1/4	1 3/4	3/4	2400	220
M2 A	10 to 6	1/4 to 3/8	1/4	1 7/8	7/8	1400	340
M3 A	6 to 2	3/8 to 1/2	5/16	2 1/4	1	1200	400
M4 A	2 to 00	1/2 to 5/8	5/16	2 1/2	1 1/8	800	580
M5 A	00 to 0000	5/8 to 13/16	3/8	2 13/16	1 1/4	700	650
M1 B	14 to 10	3/32 to 1/4	1/4	1 3/4	3/4	1800	270
M2 B	10 to 6	1/4 to 3/8	1/4	1 7/8	7/8	1150	420
M3 B	6 to 2	3/8 to 1/2	5/16	2 1/4	1	1000	480
M4 B	2 to 00	1/2 to 5/8	5/16	2 1/2	1 1/8	750	650
M5 B	00 to 0000	5/8 to 13/16	3/8	2 13/16	1 1/4	650	740
M6 B	0000 to 300,000 CM.	13/16 to 1	3/8	3	1 3/8	450	1000
M7 B	300,000 to 550,000 CM.	1 to 1 1/4	7/16	3 1/2	1 1/2	375	1400
M8 B	550,000 to 1,000,000 CM.	1 1/4 to 1 3/8	7/16	3 7/8	1 5/8	250	2300
M9 B	1,000,000 to 2,000,000 CM.	1 5/8 to 2	9/16	4 3/4	1 7/8	200	2700
M10 B	2,000,000 to 3,000,000 CM.	2 to 2 1/2	9/16	5 1/4	2	150	3350

One wire cleat regular consists of low base and low cap.
 One wire cleat A consists of low cap and base one inch high under wire.
 One wire cleat B consists of base one inch high under wire, and cap one inch high over wire.

JOSLYN MANUFACTURING & SUPPLY COMPANY

Standard Porcelain Tubes



List Prices per 1000, Barrel Quantities, Weight per Bbl.

Length Under Head	$\frac{5}{16}$ " Hole $\frac{1}{2}$ " Outside Diameter		$\frac{3}{8}$ " Hole $\frac{5}{8}$ " Outside Diameter		$\frac{1}{2}$ " Hole $\frac{3}{4}$ " Outside Diameter		$\frac{5}{8}$ " Hole $1\frac{1}{8}$ " Outside Diameter		$\frac{3}{4}$ " Hole $1\frac{3}{8}$ " Outside Diameter	
	Barrel	Weight 1000	Barrel	Weight 1000	Barrel	Weight 1000	Barrel	Weight 1000	Barrel	Weight 1000
1/2"	18,000	21	14,000	28	7,000	57	4,500	84	3,700	90
1"	11,000	34	7,500	51	6,000	62	3,200	117	2,500	128
1 1/2"	9,500	40	6,500	57	4,200	82	2,500	117	1,800	128
2"	7,000	45	5,000	71	3,400	99	2,500	142	1,800	172
2 1/2"	5,500	56	4,000	76	2,200	125	2,000	163	1,500	197
3"	4,500	63	3,100	90	2,000	140	1,800	180	1,100	260
4"	3,600	80	2,300	117	1,400	196	1,200	221	850	294
5"	2,900	98	1,900	142	1,200	246	1,100	275	650	400
6"	2,000	117	1,400	180	1,000	275	900	320	525	485
8"	1,500	160	1,200	238	800	350	700	400	400	590
10"	1,500	187	1,000	265	600	440	500	500	245	700
12"	1,000	260	850	300	525	470	375	600	300	800
14"	700	310	550	370	400	510	310	700	250	920
16"	550	390	435	460	325	610	250	820	185	1,100
18"	425	450	325	520	280	700	200	1,025	160	1,250
20"	360	515	225	690	200	800	160	1,100	125	1,440
24"	350	570	225	780	200	900	160	1,220	125	1,700
30"										
36"										
42"										
48"										

Tube list dimensions conform to the rules of the Underwriters' Board.

Length Under Head	1" Hole 1 1/8" Outside Diameter		1 1/4" Hole 1 3/8" Outside Diameter		1 1/2" Hole 2" Outside Diameter		1 3/4" Hole 2 1/8" Outside Diameter	
	Barrel	Weight 1000	Barrel	Weight 1000	Barrel	Weight 1000	Barrel	Weight 1000
1"	1,900	200						
1 1/2"	1,500	240	650	520	450	770		
2"	1,100	314	600	550	400	840	275	1,420
2 1/2"	900	367	525	610	355	920	250	1,520
3"	800	394	425	730	300	1,050	225	1,640
4"	600	500	360	860	250	1,220	200	1,800
5"	500	580	325	940	220	1,390	175	1,920
6"	400	700	250	1,200	180	1,610	150	2,130
8"	325	890	180	1,600	140	2,140	145	2,500
10"	245	1,100	140	1,800	110	2,550	140	2,900
12"	190	1,350	120	2,200	90	3,000	120	3,500
14"	150	1,530	100	2,550	75	3,470	90	3,700
16"	140	1,640	85	3,000	65	4,000	60	4,400
18"	110	1,900	70	3,350	55	4,550	50	5,000
20"	85	2,300	55	3,900	50	5,100	50	5,600
24"	85	2,530	55	4,400	50	5,650	50	6,200
30"								
36"								
42"								
48"								

Tubes longer than 24 inches are packed in special boxes to suit the length of the tubes.

Consider barrel quantities as 50 per bbl. unless otherwise listed.

For glazed tubes add 50 per cent.

For split tubes, multiply list by 10, measurements under head.

For floor tubes, multiply list by 3, measurements over all.

For split floor tubes, multiply list by 6, measurements over all.

For crossover tubes, multiply list by 6, measurements between heads.

For headless tubes, above 6 in. long, multiply list by 4, measurements over all.

For curved and curved end tubes, multiply list by 3, measurements over all.

For crossover tubes split, multiply list by 12, measurements between heads.

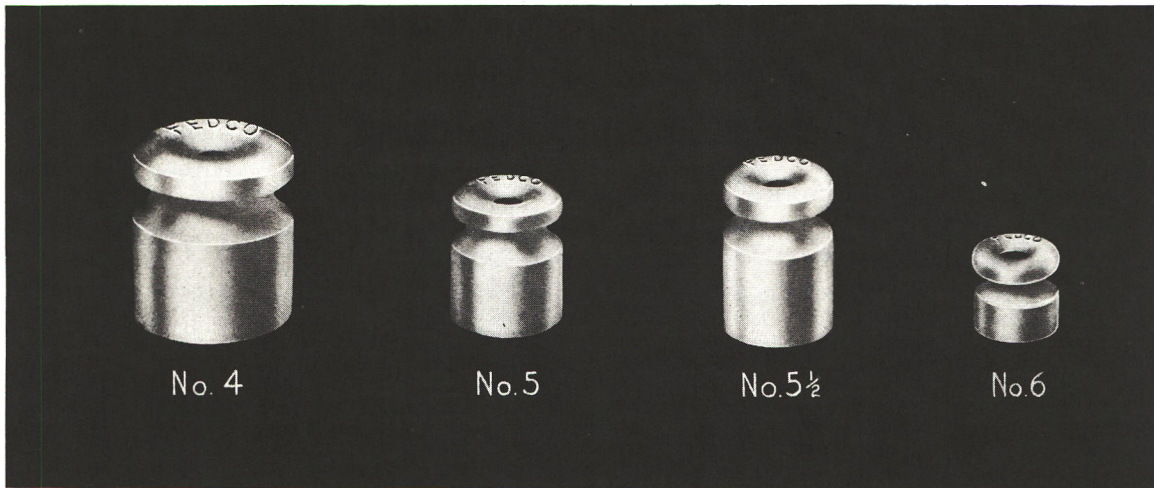

SOLID KNOBS

WHITE GLAZE STANDARD

Catalog Number	Height, Inches	Diameter, Inches	Hole, Inches	Groove, Inches	Quantity per Barrel	Shipping Weight, Lbs. per Barrel	Code Word	Price per 1,000
4	1 11/16	1 1/2	3/8	3/8	2,200	490	Abroad	\$22 00
4, 2-groove Tel. Knob	(See Telephone Knobs, page 13.)							
*4 1/2	1 7/8	1 1/2	3/8	7/16	1,900	475	Abscond	25 00
5	1 1/4	1	1/4	5/16	6,000	480	Absence	13 00
5 1/2, Old Code	1 9/16	1	1/4	5/16	5,300	500	Abstract	13 00
5 1/2, New Code	1 3/4	1 1/8	1/4	5/16	4,500	500	Accede	16 00
6	7/8	13/16	7/32	1/4	13,000	490	Accept	11 00
7	3/4	7/8	1/4	7/16	15,500	425	Acceptance	13 00
8	15/16	1	1/4	5/16	9,000	475	Access	13 00
9	1 1/8	5/8	3/16	3/16	15,000	475	Accident	16 00
10	1 3/4	1 5/8	3/8	3/8	2,000	490	Accommodate	30 00
*10 1/2	1 7/8	1 5/8	3/8	3/8	2,000	490	Accompany	30 00

* At request of the Government, manufacture will be discontinued after stock on hand is exhausted.

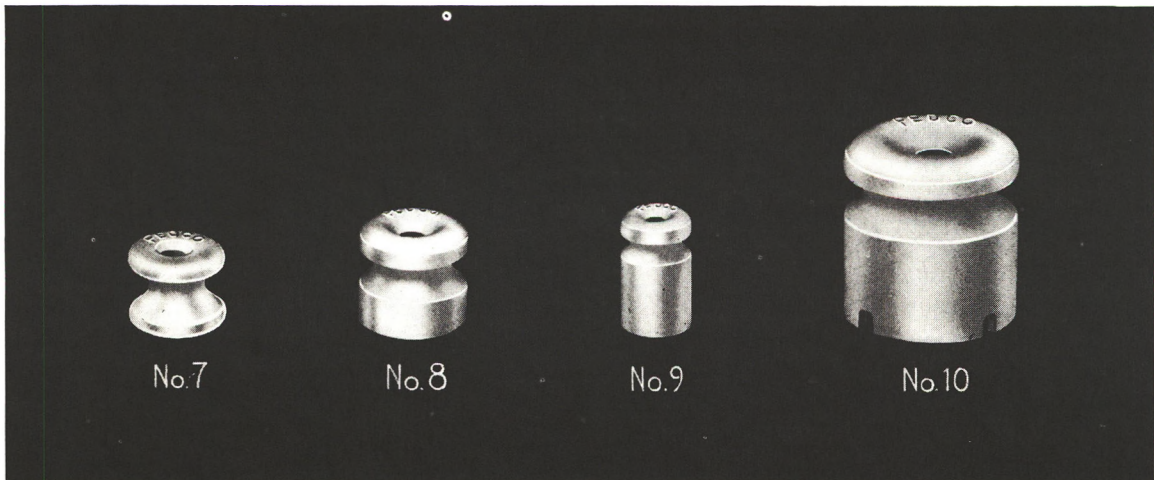

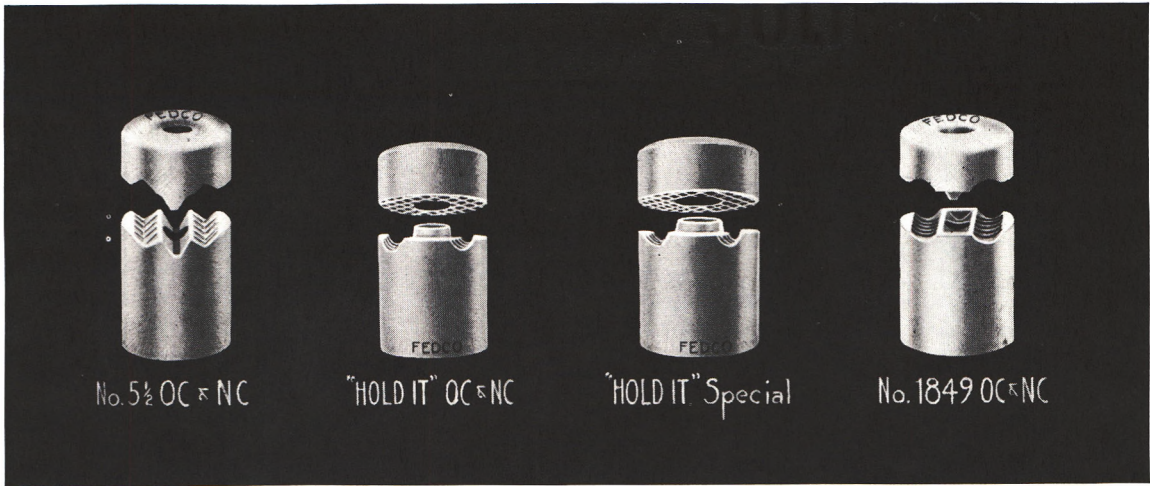

SPLIT KNOBS

WHITE GLAZE STANDARD

Catalog Number	Height, Inches	Diameter, Inches	Size of Wire	Number Pair per Barrel	Shipping Weight, Lbs. per Barrel	Code Word	Price per 1,000 Pair
1829 (1-wire)	1 7/8	1	12-14	4,000	500	Approximate	\$22 00
*5 1/2, Old Code	1 3/4	1	12-14	4,500	525	Arbitrate	22 00
*"Hold-it," Old Code	1 3/4	1	12-14	4,500	500	Arrange	22 00
*1849, Old Code	1 3/4	1	12-14	4,500	525	Arrest	22 00
9417	1 3/4	1 1/8	12-14	3,500	490	Arrival	24 00
5 1/2, New Code	1 3/4	1 1/8	12-14	4,000	500	Article	24 00
1849, New Code	1 3/4	1 1/8	12-14	4,000	500	Ascertain	24 00
"Hold-it," New Code	1 3/4	1 1/8	12-14	3,200	480	Asked	24 00
"Hold-it," Special	1 3/4	1 3/16	12-14	3,000	500	Assay	26 00
"Detroit"	1 3/4	1 1/4	12-14	3,000	500	Assent	26 00
33	1 7/8	1 3/8	12-14	1,500	435	Assertion	37 00
9419	1 7/8	1 1/2	8-10	2,000	500	Assess	41 00
9420	2 1/8	2	4-6	1,000	475	Assign	63 00

* At request of the Government, manufacture will be discontinued after stock on hand is exhausted.

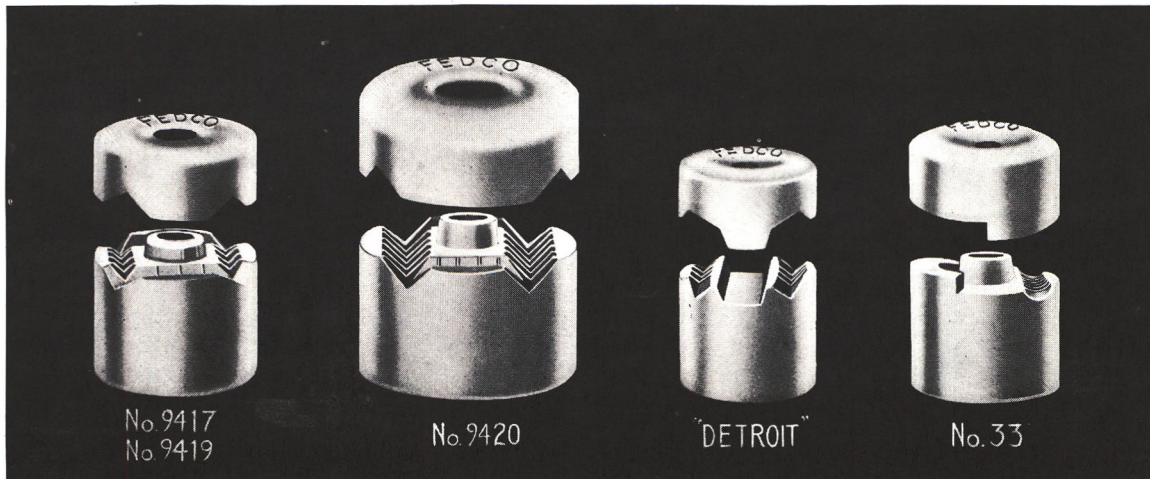

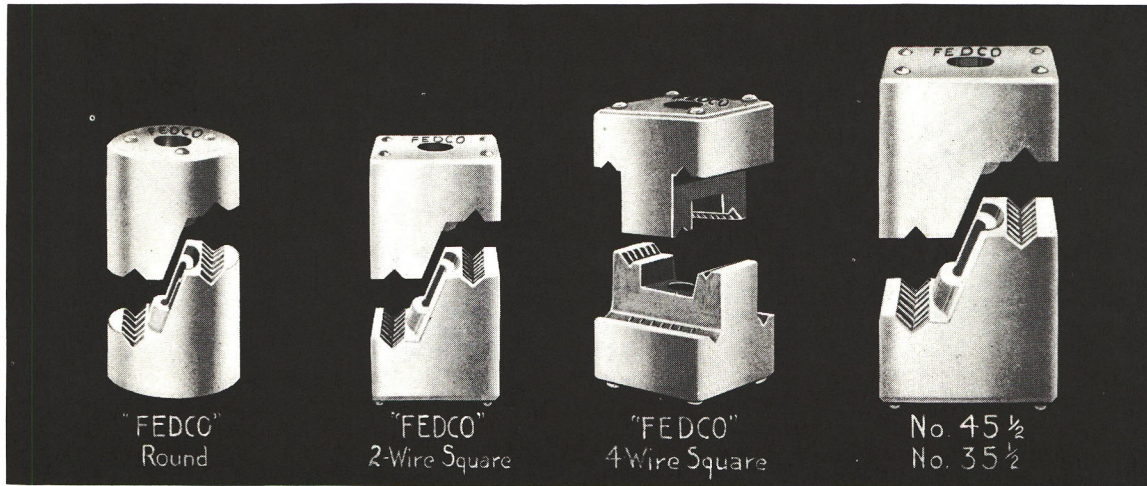

SPLIT KNOBS—REVERSIBLE (WHITE GLAZE STANDARD)

Catalog Number	Height, Inches	Diameter, Inches	Size of Wire	Number Pair per Barrel	Shipping Weight, Lbs. per Barrel	Code Packed in Bbls.	Word Packed in Boxes of 500	Price per 1,000 Pair
"Fedco," Round, 2-wire	1 3/4	1 1/8	12-14	3,700	500	Assignment		\$26 00
"Fedco," Square, 2-wire	1 3/4	1 1/8	12-14	3,500	490	Assist		26 00
"Fedco," Round, 4-wire	1 3/4	1 1/8	12-14	3,400	500	Assistance		28 00
"Fedco," Square, 4-wire	1 3/4	1 1/8	12-14	3,200	480	Assize		30 00
45 1/2	2 1/4	1 1/2	8-10	2,000	500	Associate		48 00
35 1/2	2 1/2	2	4-6	1,000	500	Association		69 00

SPLIT "NAIL-KNOBS" AND "SCREW-KNOBS" (WHITE GLAZE STANDARD)

"Nail-Knobs"	No.1 (New Code)	1 3/4	1 1/8	12-14	3,200	485	Assort	Attach	\$32 00
	No. 2 (Old Code)	1 3/4	1	12-14	4,500	530	Attachment	Attempt	30 00
"Screw-Knobs"	"Detroit," Size	1 3/4	1 1/4	12-14	2,400	480	Attend	Attention	34 00
	No. 1 (New Code)	1 3/4	1 1/8	12-14	3,200	500	Attorney	Attune	40 00
	No. 2 (Old Code)	1 3/4	1	12-14	4,500	540	Audit	Authority	38 00
	"Detroit," Size	1 3/4	1 1/4	12-14	2,400	490	Avail	Average	42 00

NOTE:—"Nail-Knobs" and "Screw-Knobs" regularly shipped in barrels, unless otherwise specified. Prices subject to regular barrel or boxing additional charge, according to method of packing used.

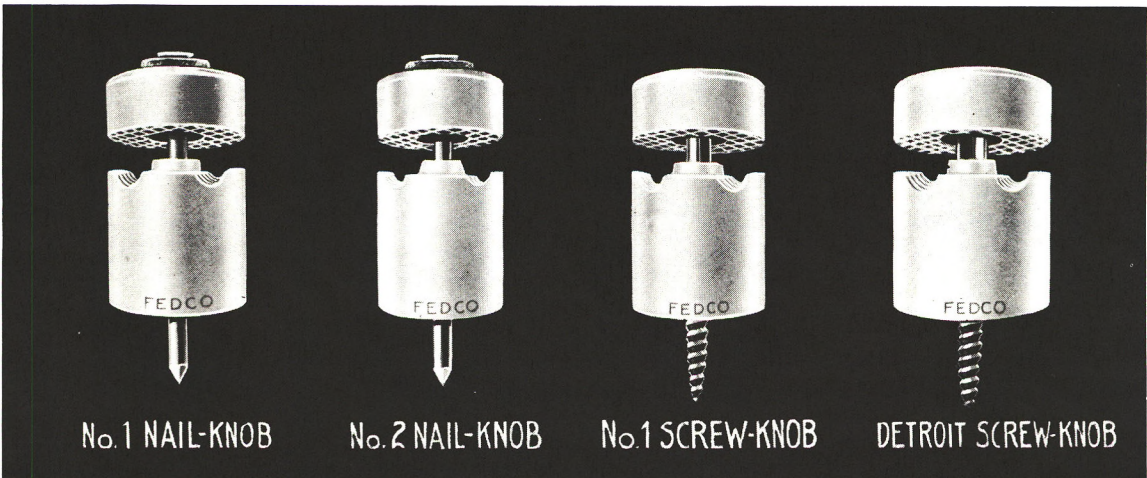

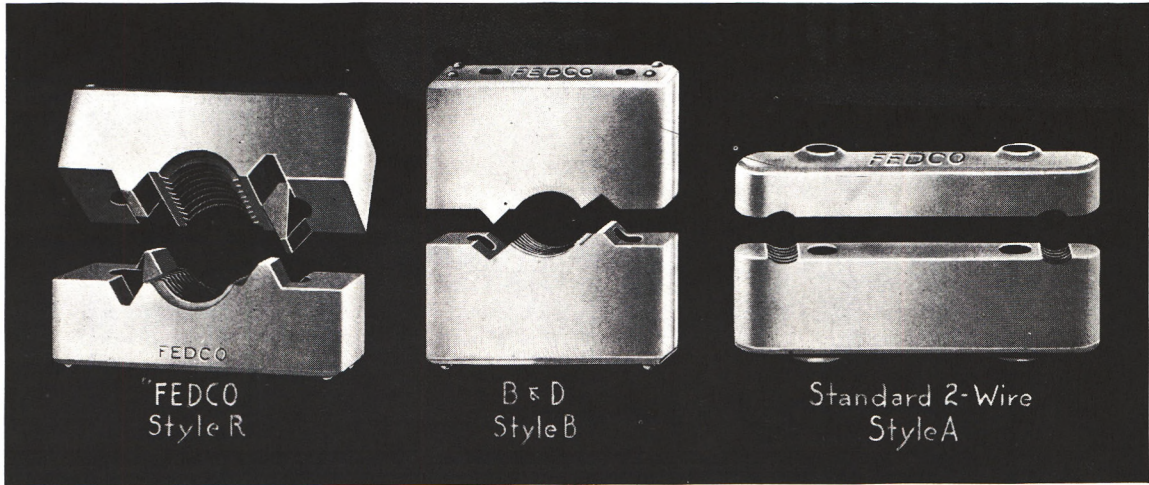

"FEDCO" REVERSIBLE and "B. & D." ONE-WIRE GLAZED CLEATS

WHITE GLAZE and ROUND GROOVE STANDARD. *V-GROOVE CAN BE FURNISHED IF SPECIFIED

When ordering, be sure to specify whether "Fedco" or "B. & D." cleats wanted. "Fedco" reversible cleats will be shipped unless otherwise specified.

†Cat. No.	Size Wire	Height Inches	Width Inches	Length Inches	Groove Inches	Number Pair per Barrel	Shipping Weight, Lbs. per Barrel	Code "Fedco"	Word "B. & D."	Price per 1,000 Pair
1R	14-6	1 3/8	1 3/4	1 1/2	1/8-3/8	3,000	490	Cabinet	Dabble	\$28 00
1A	14-6	1 1/2	1 3/4	1 1/2	1/8-3/8	2,300	510	Cable	Dagger	39 00
1B	14-6	2 1/8	1 3/4	1 1/2	1/8-3/8	1,700	500	Caboose	Dainty	50 00
1 1/2 R	6-2	1 3/8	1 1/2	2 1/4	3/16-7/16	2,000	490	Calendar	Damper	43 00
1 1/2 A	6-2	1 5/8	1 1/2	2 1/4	3/16-7/16	1,550	500	Cambic	Dance	54 00
1 1/2 B	6-2	2 3/16	1 1/2	2 1/4	3/16-7/16	1,200	490	Campus	Debate	65 00
2R	2-0	1 5/8	1 1/4	2 1/4	3/8-1/2	1,500	490	Canvas	Debtor	52 00
2A	2-0	2	1 1/4	2 1/4	3/8-1/2	1,350	490	Capital	Decade	65 00
2B	2-0	2 3/8	1 1/4	2 1/4	3/8-1/2	1,200	500	Carbon	Decant	78 00
2 1/2 R	0-000	1 7/8	1 3/4	2 1 1/4	1/2-5/8	1,100	500	Carpet	Defend	65 00
2 1/2 A	0-000	2 3/16	1 3/4	2 1 1/4	1/2-5/8	900	500	Cascade	Defiant	79 00
2 1/2 B	0-000	2 1/2	1 3/4	2 1 1/4	1/2-5/8	700	500	Cement	Deflect	91 00
3R	000-200M	2 1/4	1 1/4	3 3/8	9/16-3/4	700	480	Century	Degree	86 00
3A	000-200M	2 3/8	1 1/4	3 3/8	9/16-3/4	600	490	Chain	Delegate	103 00
3B	000-200M	2 1/2	1 1/4	3 3/8	9/16-3/4	500	500	Chapter	Delight	120 00
3 1/2 B	10 Duplex Parallel	2 3/4	1 5/8	3 3/8	3/4-1	600	490	Chimney	Delude	130 00
3 1/2 B	200M-500M	2 3/4	1 5/8	3 3/8	3/4-1	550	480	Chisel	Demand	130 00
4B	500M-1MM	3	1 3/8	3 3/4	1 -1 3/8	400	475	Cigar	Demure	173 00
4 1/2 B	800M-1 1/4MM	3 3/8	1 7/8	5	1 3/8-1 5/8	190	480	Clock	Denote	346 00
4 1/2 B	1MM-2MM	3 5/8	2	5 7/8	1 7/8-1 15/16	165	490	Cluster	Depart	432 00

† Specify "Fedco" or "B. & D." * If V-Groove cleats are wanted, add VE to beginning of Code Word: Vecabinet, vedabble, etc.

TWO AND THREE-WIRE CLEATS

GLAZED AND UNGLAZED—UNGLAZED SHIPPED UNLESS OTHERWISE SPECIFIED

Size Wire and Style	No. Pair	Shipping Weight Lbs. per Barrel	WHITE GLAZED				Price per 1,000 Pair	UNGLAZED				Price per 1,000 Pair
			Two-Wire		Three-Wire			Two-Wire		Three-Wire		
			Cat. No.	Code Word	Cat. No.	Code Word	Cat. No.	Code Word	Cat. No.	Code Word		
STANDARD TYPE—ROUND GROOVES												
12-14 R	2,250	400	G122	Eagle	G123	Emblem	\$34 00	122	Encourage	123	Enterprise	\$21 00
12-14 A	1,500	500	G122A	Earnest	G123A	Emboss	55 00	122A	Endanger	123A	Entertain	38 00
8-10 R	1,800	490	G102	Earth	G103	Emerge	69 00	102	Endeavor	103	Entitle	43 00
8-10 A	1,000	480	G102A	Easter	G103A	Emotion	112 00	102A	Endorse	103A	Entrust	78 00
HEAVY MILL TYPE—ROUND GROOVES												
12-14 R	1,500	490	G212	Ebony	G312	Empire	69 00	212	Enforce	312	Equal	43 00
12-14 A	1,000	490	G212A	Edict	G312A	Employ	112 00	212A	Engage	312A	Equity	78 00
8-10 R	1,000	480	G210	Effect	G310	Empty	69 00	210	Engine	310	Erect	43 00
8-10 A	900	480	G210A	Effort	G310A	Enable	112 00	210A	Enlarge	310A	Error	78 00
V-GROOVE—(Same Type and Dimensions as "Duggan" Cleats).												
8-16 R	2,000	450	G216	Elapse	G316	Enclose	34 00	216	Enough	316	Escape	21 00
00-6 R	1,000	400	G206	Elbow			69 00	206	Enter			43 00

NOTE:—Applying on all cleats listed on this and opposite page: **Style R (Regular)** Cleats have wire grooves 1/2-inch from surface, both cap and base. **Style A** Cleats have wire grooves 1-inch from surface of base, 1/2-inch from surface of cap. **Style B** Cleats have wire grooves 1-inch from surface of both cap and base.

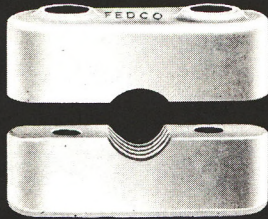

Standard 1-wire
Style R



No. 314



No. 333



No. 315



No. 333 1/2

STANDARD ONE-WIRE GLAZED CLEATS

WHITE GLAZE and ROUND GROOVE STANDARD. *V-GROOVE CAN BE FURNISHED IF SPECIFIED

Catalog Number	Size Wire	Height Inches	Width Inches	Length Inches	Groove Inches	Number Pair per Barrel	Shipping Weight, Lbs. per Barrel	*Code Word	Price per 1,000 Pair
11R (328R)	14-6	1 1/4	3/4	2	3/16	2,800	480	Fabric	\$28 00
11A (328A)	14-6	1 3/16	3/4	2	3/16	2,700	480	Faction	39 00
11B (328B)	14-6	2 3/8	3/4	2	3/16	1,800	470	Faculty	50 00
22R (329R)	10-4	1 3/4	7/8	2 1/4	1/4	1,900	460	Famous	43 00
22A (329A)	10-4	2 1/8	7/8	2 1/4	1/4	1,600	460	Favorite	54 00
22B (329B)	10-4	2 1/2	7/8	2 1/4	1/4	1,200	450	Feather	65 00
33R (330R)	4-2	1 3/4	1	2 1/2	3/8	1,700	470	Fellow	52 00
33A (330A)	4-2	2 1/2	1	2 1/2	3/8	1,400	470	Fence	65 00
33B (330B)	4-2	3 1/4	1	2 1/2	3/8	1,050	470	Ferry	78 00
44R (331R)	2-0	2 1/4	1 1/8	2 3/4	1/2	950	470	Fertile	65 00
44A (331A)	2-0	2 1/2	1 1/8	2 3/4	1/2	800	470	Festive	78 00
44B (331B)	2-0	2 3/4	1 1/8	2 3/4	1/2	725	460	Figure	91 00
55R (332R)	0-000	2 3/8	1 1/4	3	5/8	875	480	Filter	86 00
55A (332A)	0-000	2 19/32	1 1/4	3	5/8	750	470	Finger	103 00
55B (332B)	0-000	2 13/16	1 1/4	3	5/8	650	470	Florist	120 00
66B (343)	000-500M	3 1/4	1 3/8	3 1/2	3/4	450	460	Follow	130 00
77B (344)	500M-700M	3 3/8	1 1/2	3 3/4	1	375	450	Foreman	173 00
88B (345)	750M-1 1/4MM	3 3/4	1 3/4	4 3/4	1 1/4	250	440	Forest	346 00
99B (346)	1 1/4MM-2MM	4	2	5	1 1/2	175	450	Freedom	432 00

* If V-groove cleats are wanted, add VE to beginning of code word: Vefabric, Vefaction, etc

TELEPHONE CLEATS

WHITE GLAZE STANDARD

Catalog Number	Width, Inches	Length, Inches	Number of Grooves	Groove, Inches	Quantity per Barrel	Shipping Weight, Lbs. per Barrel	Code Word	Price per 1,000
314 (Top)	7/8	2 1/8	4	5/32	3,000	350	Guard	\$23 00
315 (Back)	7/8	2 1/8	3,000	375	Guest	23 00
314 and 315 (Comp.)	Guitar	46 00
333 (Top)	1/2	1 3/16	1	1/4	21,500	465	Gumption	10 00
333 1/2 (Back)	1/2	1 3/16	22,000	475	Gunwale	11 00
333 and 333 1/2 (Comp.)	Gypsum	21 00



The FEDERAL PORCELAIN COMPANY

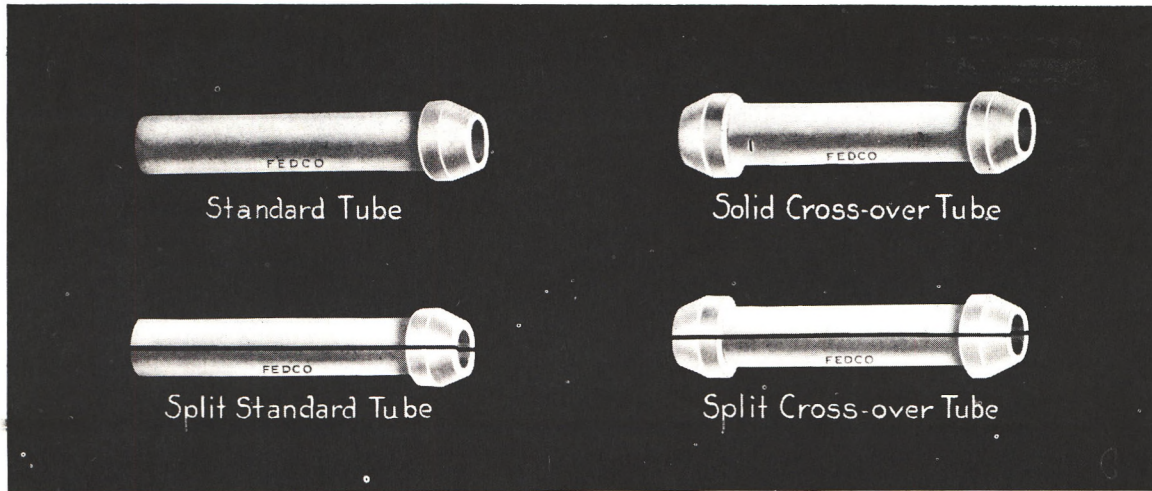

STANDARD TUBES
UNGLAZED

List prices per 1000. Tube list dimensions conform to the new rules of the Underwriters' Board.

Length, Inches Under Head	$\frac{1}{16}$ I. D.	$\frac{3}{16}$ I. D.	$\frac{1}{2}$ I. D.	$\frac{5}{8}$ I. D.	$\frac{3}{4}$ I. D.	1 I. D.	$1\frac{1}{8}$ I. D.	$1\frac{1}{2}$ I. D.	$1\frac{3}{4}$ I. D.	2 I. D.	$2\frac{1}{4}$ I. D.	$2\frac{1}{2}$ I. D.	$2\frac{3}{4}$ I. D.	3 I. D.	Code Word
	$\frac{1}{16}$ O.D.	$\frac{3}{16}$ O.D.	$\frac{1}{2}$ O.D.	$\frac{5}{8}$ O.D.	$\frac{3}{4}$ O.D.	1 $\frac{1}{16}$ O.D.	$1\frac{1}{8}$ O.D.	$1\frac{1}{4}$ O.D.	$1\frac{3}{8}$ O.D.	$2\frac{1}{16}$ O.D.	$2\frac{3}{16}$ O.D.	$3\frac{1}{16}$ O.D.	$3\frac{1}{2}$ O.D.	$4\frac{1}{2}$ O.D.	
	Ha	He	Hi	Ho	Hu	Ja	Je	Ji	Jo	Ju	Ka	Ke	Ki	Ko	Begin- ning
$\frac{1}{2}$	\$ 13.00	\$ 15.00	\$ 21.00												Ending
1	13.00	15.00	21.00	\$ 27.00	\$ 39.00	\$ 59.00									ba
$1\frac{1}{2}$	14.00	16.00	22.00	28.00	43.00	69.00	\$122.00	\$156.00							be
2	15.00	19.00	26.00	34.00	55.00	78.00	122.00	156.00	\$ 198.00	\$ 234.00					bo
$2\frac{1}{2}$	16.00	22.00	30.00	40.00	65.00	91.00	122.00	156.00	198.00	234.00	\$ 268.00	\$ 303.00	\$ 455.00	\$ 682.00	bu
3	18.00	26.00	34.00	47.00	72.00	104.00	138.00	174.00	220.00	258.00	296.00	325.00	488.00	732.00	ca
4	27.00	32.00	41.00	55.00	88.00	130.00	156.00	192.00	239.00	277.00	315.00	353.00	529.00	794.00	ce
5	33.00	38.00	48.00	64.00	104.00	163.00	181.00	253.00	341.00	417.00	488.00	568.00	852.00	1278.00	ci
6	40.00	48.00	55.00	73.00	124.00	186.00	200.00	312.00	453.00	579.00	705.00	832.00	1248.00	1872.00	co
8	72.00	84.00	96.00	108.00	156.00	218.00	240.00	384.00	581.00	739.00	898.00	1056.00	1584.00	2376.00	cu
10	96.00	108.00	120.00	180.00	218.00	250.00	312.00	456.00	660.00	818.00	977.00	1135.00	2000.00	3000.00	da
12	144.00	156.00	168.00	240.00	281.00	343.00	456.00	692.00	1021.00	1280.00	1540.00	1800.00	3000.00	4050.00	de
14	242.00	277.00	311.00	432.00	495.00	540.00	761.00	1175.00	1748.00	2204.00	2662.00	3118.00	4000.00	6000.00	di
16	347.00	389.00	432.00	519.00	585.00	674.00	900.00	1314.00	1901.00	2358.00	2814.00	3269.00	4903.00	7355.00	do
18	389.00	432.00	519.00	605.00	674.00	764.00	1037.00	1472.00	2284.00	2809.00	3332.00	3853.00	5779.00	8670.00	du
20	432.00	476.00	563.00	648.00	719.00	853.00	1141.00	1625.00	2537.00	3310.00	3691.00	4271.00	6406.00	9610.00	fa
22	497.00	540.00	605.00	692.00	810.00	922.00	1244.00	1780.00	2779.00	3421.00	4064.00	4708.00	7061.00	10591.00	fe
24	563.00	605.00	648.00	735.00	900.00	1000.00	1348.00	1936.00	3028.00	3733.00	4439.00	5142.00	7712.00	11569.00	fi
26	620.00	680.00	730.00	810.00	980.00	1160.00	1850.00	2500.00	3800.00	4800.00	5700.00	6600.00	9500.00	15000.00	fo
28	690.00	740.00	800.00	900.00	1070.00	1280.00	2030.00	2870.00	4500.00	5640.00	6710.00	7770.00	11660.00	17490.00	fu
30	770.00	810.00	890.00	990.00	1170.00	1410.00	2220.00	3150.00	4950.00	6210.00	7470.00	8550.00	12830.00	19250.00	ga
32	840.00	900.00	980.00	1080.00	1290.00	1550.00	2450.00	3470.00	5450.00	6830.00	8120.00	9510.00	14270.00	21410.00	ge
34	920.00	990.00	1070.00	1200.00	1410.00	1700.00	2700.00	3830.00	5990.00	7520.00	8930.00	10350.00	15670.00	23280.00	gi
36	1010.00	1080.00	1170.00	1320.00	1560.00	1880.00	2970.00	4200.00	6590.00	8270.00	9830.00	11390.00	17070.00	25620.00	go
38	1100.00	1190.00	1290.00	1440.00	1710.00	2060.00	3270.00	4620.00	7250.00	9090.00	10800.00	12530.00	18780.00	28170.00	gu
40	1200.00	1310.00	1430.00	1590.00	1890.00	2270.00	3590.00	5090.00	7970.00	9990.00	11880.00	13770.00	20660.00	31000.00	ha
42	1320.00	1440.00	1580.00	1760.00	2070.00	2340.00	3950.00	5600.00	8780.00	11000.00	13080.00	15150.00	22730.00	34100.00	he
44	1460.00	1590.00	1730.00	1940.00	2280.00	2750.00	4350.00	6150.00	9650.00	12090.00	14390.00	16670.00	25010.00	37500.00	hi
46	1590.00	1760.00	1890.00	2120.00	2520.00	3020.00	4790.00	6770.00	10610.00	13310.00	15830.00	18330.00	27510.00	41270.00	ho
48	1760.00	1920.00	2090.00	2300.00	2760.00	3320.00	5270.00	7460.00	11670.00	14640.00	17400.00	20160.00	30260.00	45380.00	hu
50	1940.00	2120.00	2300.00	2500.00	3050.00	3660.00	5790.00	8190.00	12840.00	16090.00	19140.00	22190.00	33270.00	49900.00	ka

Code Word Example— $\frac{1}{2}$ " x $1\frac{3}{16}$ " x 3" Tubes: Hica.
3" x $4\frac{1}{2}$ " x 50" Tubes: Koka.

For Special Tubes and Glazing, see opposite page.

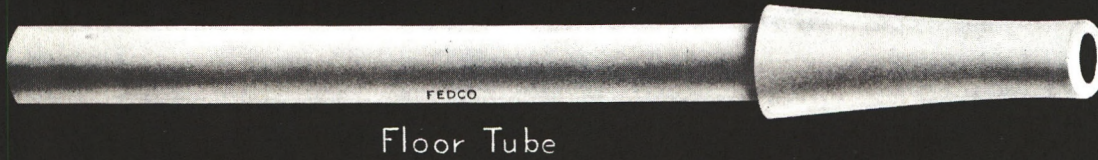
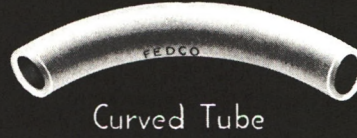
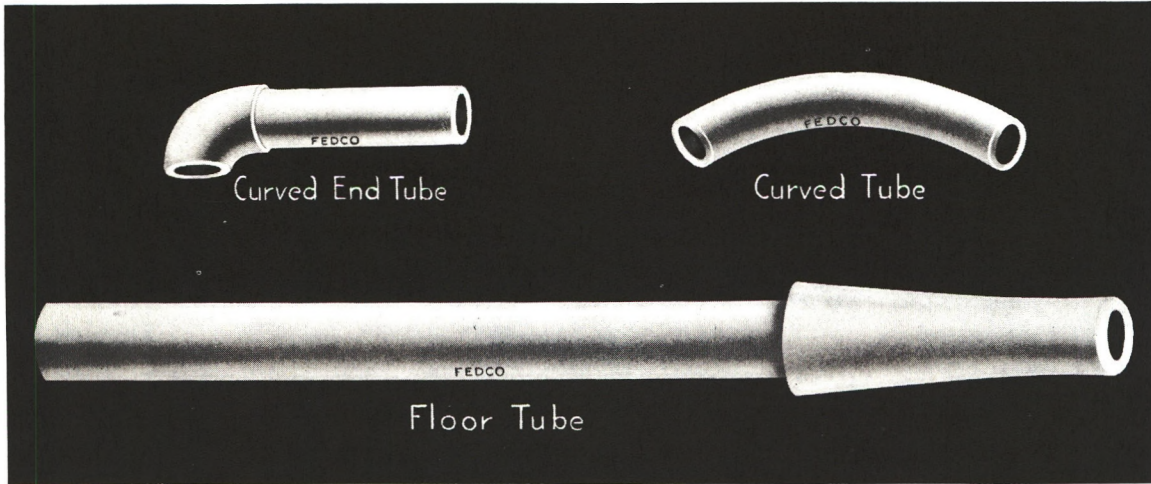

Special Tubes

The following additions apply on standard tube list shown on opposite page:

For **Split Regular Tubes**, multiply list by 10.
Measurements under heads.
Code word ending: LA.

For **Solid Cross-Over Tubes**, multiply list by 6.
Measurements between heads.
Code word ending: LE.

For **Split Cross-Over Tubes**, multiply list by 12.
Measurements between heads.
Code word ending: LI.

For **Solid Floor Tubes**, multiply list by 3.
Measurements over all.
Code word ending: LO.

For **Split Floor Tubes**, multiply list by 6.
Measurements over all.
Code word ending: LU.

For **Curved Tubes**, multiply list by 3.
Measurements over all.
Code word ending: MA.

For **Curved End Tubes**, multiply list by 3.
Measurements over all.
Code word ending: ME.

For **Headless Tubes Above 8" Long**, multiply list by 4. Tubes 8" long or under take standard list.
Measurements over all.
Code word ending: MI.

For **Glazed Tubes**, add fifty per cent.
Code word ending: White, NO.
Brown, NU.

Code Word Example: 1" x 1 1/16" x 6" Curved End Tubes, Brown Glaze—Jacomenu.

Approximate Number of Standard Tubes per Barrel.

Length in Inches Under Head	1/8" Hole, 1/8" Outside Diameter	3/16" Hole, 1/8" Outside Diameter	1/4" Hole, 1/8" Outside Diameter	5/16" Hole, 1/8" Outside Diameter	3/8" Hole, 1 1/8" Outside Diameter	1 Hole, 1 1/8" Outside Diameter	1 1/4" Hole, 1 1/8" Outside Diameter	1 1/2" Hole, 2 1/8" Outside Diameter	1 3/4" Hole, 2 1/8" Outside Diameter
1/2	18,000	14,000
1	11,000	7,500	6,000	4,500	3,700
1 1/2	9,500	6,500	4,200	3,200	2,500
2	7,500	5,000	3,400	2,500	1,800	1,500
2 1/2	6,000	4,000	2,800	2,000	1,500	900	525	350	250
3	5,300	3,800	2,300	1,800	1,250	750	425	300	225
3 1/2	3,600	2,900	1,850	1,450	850	600	360	250	200
4	2,800	2,400	1,600	1,200	700	500	325	225	175
5	2,200	2,150	1,400	1,000	600	400	250	180	150
6	2,000	1,600	1,100	700	450	325	225	150	140
8	1,800	1,400	1,000	650	450	300	200	150	140
10	1,600	1,200	750	500	400	225	150	125	120
12	1,300	900	600	450	350	200	120	100	90
14	750	600	450	350	225	150	85	65	60
16	650	500	300	200	160	110	70	55	50
18	550	450	275	175	140	100	65	50	45
20	550	450	275	175	140	100	65	50	45
22	550	450	275	175	140	100	65	50	45
24	550	450	275	175	140	100	65	50	45

Approximate Shipping Weight Pounds per Barrel.

1/2	380	370
1	370	360	355	350	330
1 1/2	370	350	335	325	320	320
2	355	345	325	315	310	305
2 1/2	335	325	315	305	295	295	310	305	350
3	315	300	290	290	285	280	305	300	340
4	300	290	270	265	275	265	300	295	330
5	285	280	260	260	255	260	290	285	320
6	260	270	250	260	255	255	280	275	310
8	335	310	300	275	245	265	275	285	300
10	330	295	275	255	240	260	265	275	290
12	260	235	235	225	240	255	265	260	280
14	235	225	220	215	230	230	255	255	260
16	225	200	200	205	205	230	240	250	250
18	215	195	195	200	200	200	230	245	240
20	190	170	170	175	185	190	205	200	200
22	190	180	170	180	190	195	205	210	220
24	200	190	180	185	195	200	210	220	230

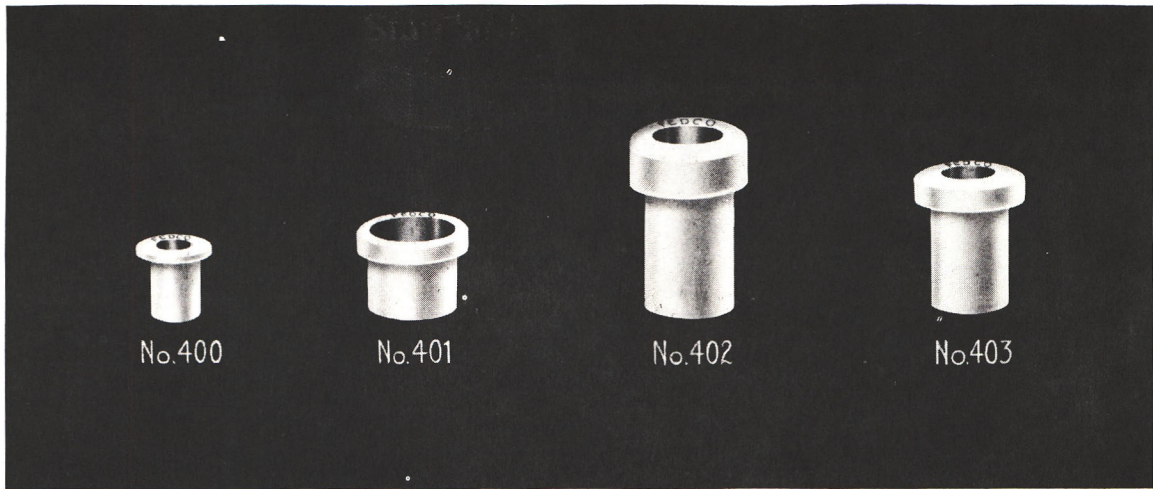

**BATTERY BUSHINGS
WHITE GLAZE STANDARD**

Catalog Number	Height, Inches	Diameter, Inches	Hole, Inches	Quantity per Barrel	Shipping Weight, Lbs. per Barrel	Code Word	Price per 1,000
400.....	$\frac{9}{16}$	$\frac{1}{2}$	$\frac{1}{4}$	15,000	400	Object	\$26 00
401.....	$\frac{5}{8}$	$\frac{3}{4}$	$\frac{5}{16}$	9,000	375	Obligation	22 00
402.....	$1\frac{1}{8}$	$\frac{11}{16}$	$\frac{3}{8}$	5,000	325	Obtain	26 00
403.....	1	$\frac{3}{4}$	$\frac{3}{16}$	5,000	350	Offer	34 00

**CEILING BUTTONS
WHITE GLAZE STANDARD**

70.....	1	$1\frac{9}{16}$	$\frac{3}{8}$	2,900	450	Office	\$45 00
170.....	$1\frac{1}{8}$	$1\frac{3}{8}$	$\frac{1}{2} \times \frac{5}{8}$	1,800	420	Official	70 00

**SECONDARY RACK INSULATORS
BROWN GLAZE STANDARD**

Catalog Number	Height, Inches	Diameter, Inches	Quantity per Barrel	Shipping Weight, Lbs. per Barrel	Code Word	Price per 1,000
SRI-1.....	3	3	300	350	Often	\$100 00

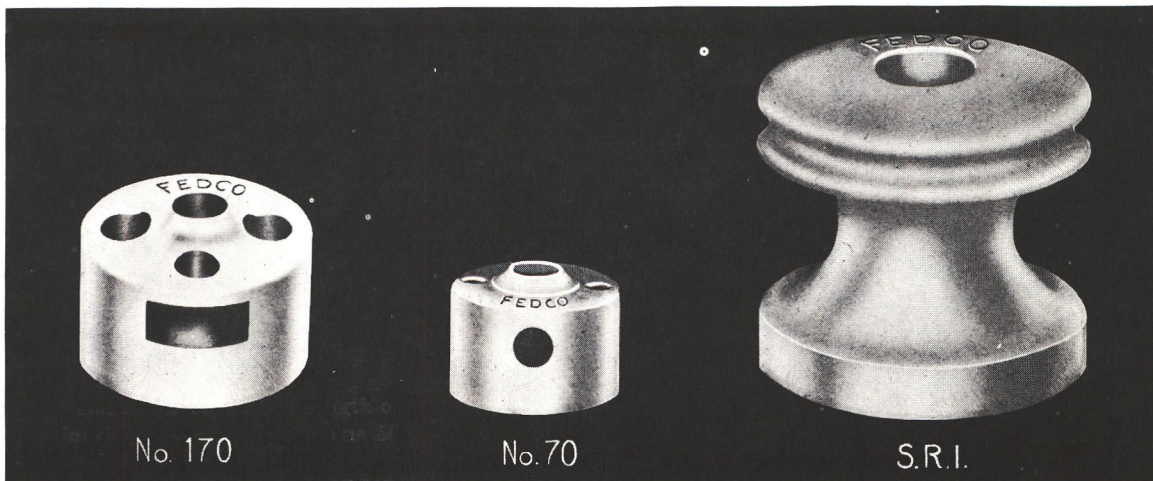

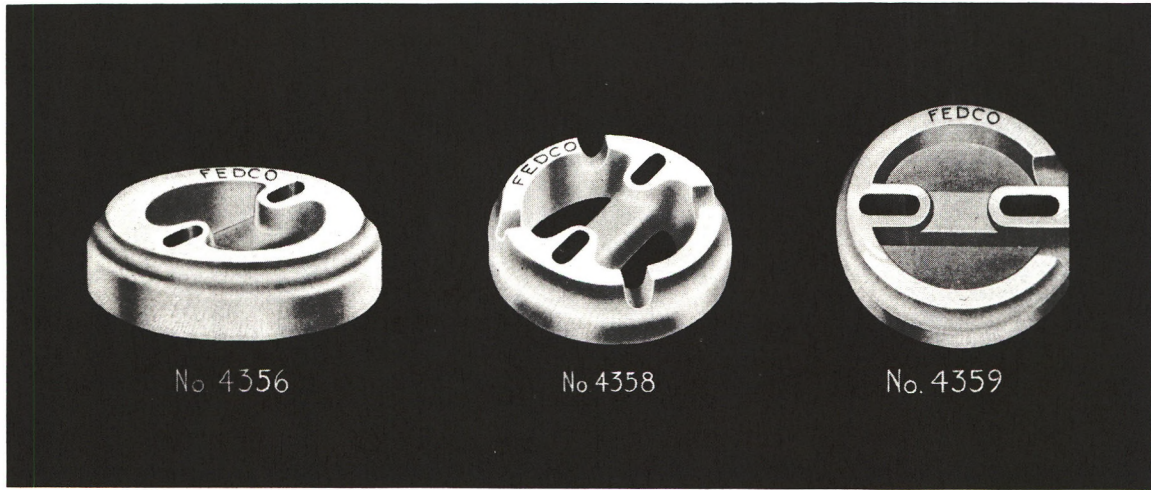

SUB-SWITCH BASES

WHITE GLAZE STANDARD

Catalog Number	For Ampere Switch	Type	Quantity per Barrel	Shipping Weight, Lbs. per Barrel	Code Word	Price per 1,000
4356.....	5	Concealed.....	2,000	400	Oils	\$42 00
4358.....	5	Cleat and concealed.....	2,000	400	Omission	42 00
4359.....	5	Moulding (end).....	2,000	400	Omitted	42 00
4360.....	5	Moulding (run) and concealed.....	2,000	400	Onyx	42 00
2697.....	10	Concealed.....	1,800	375	Operate	60 00
4361.....	10	Cleat and concealed.....	1,800	375	Operation	60 00
4357.....	10	Moulding (end).....	1,800	375	Opinion	60 00
2779.....	10	Moulding (run) and concealed.....	1,800	375	Opportunity	60 00
2780.....	10	Square—Combination.....	1,500	480	Oppose	60 00
2778.....	10	Square—Combination.....	1,500	480	Option	60 00

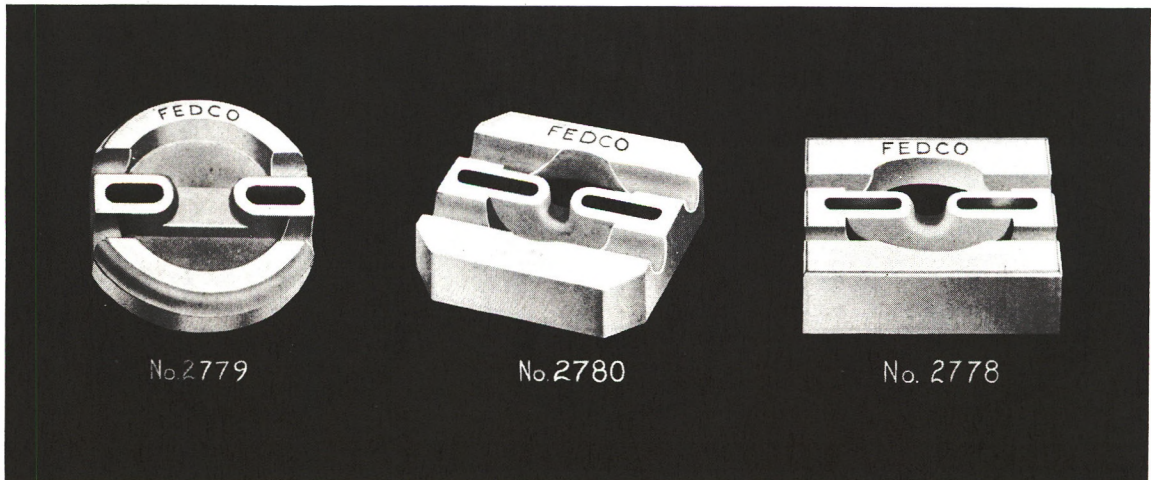

INSULATOR DESCRIPTIONS & TERMINOLOGY

Aside from the very common cleats, knobs and tubes used for surface wiring, there are many forms of associated insulators of all types, most of which were manufactured by the dry process by companies described in this book. It will serve a good purpose to illustrate and describe these insulator forms. Some items in the following summary are marginally out of the realm of power wiring insulators as covered by this book, but they are included for the sake of completeness. Additional varieties of some of the insulators are illustrated in the catalog pages preceding this section. Drawings and photo cuts are from various sources and are not to any uniform scale.

Nail Knob.

Split knobs the size of Standard Porcelain #5 $\frac{1}{2}$ knobs. Also known as "Screw Knobs" when assembled with mounting screw instead of nail. These are termed "Unassembled" when sold in loose fashion, with or without the nail and fiber washer. They are termed "Assembled Knobs" when sold as pictured here, the nail most generally captivating the pieces with a press-washer under the knob's base part.

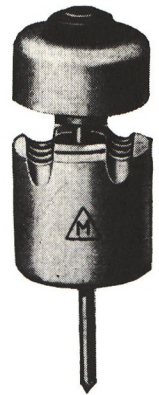

Electric Fence Knob.

Generally solid knobs of size #5 $\frac{1}{2}$, sold either assembled or unassembled. The conductor was usually secured with a "spring wire clip fastener" (not shown). Some varieties have threaded base counterbores for securing nail studs or caps with wire pigtails which are used to mount the knobs on T-shaped metal fence posts.

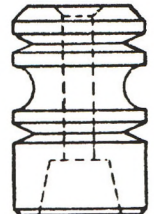

Reversible Knobs (& Cleats).

All forms of knobs and cleats which are made of two parts which are identical. The primary advantage of reversible designs is that contractors need stock and install only one item instead of two. Even though nail knobs did not use reversible parts, installers had to deal with only one item, since they were generally sold "assembled".

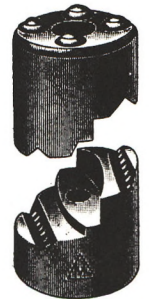

Self-tying Knobs (& Cleats).

All forms of knobs and cleats designed to hold conductor without the use of a clamping action or tie wire. All the insulators could be installed and the wires run later. Similarly, the wires could be removed and replaced at will without removing the insulator. These are also known as "Tieless Knobs".

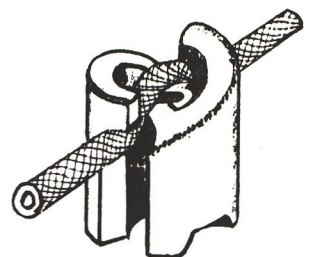

Adjustable Knobs (& Cleats).

All forms of knobs and cleats which have an adjustable feature to accommodate different sizes of conductors. Clamp insulators and split knobs with several sizes of grooves for different wire sizes are not referred to as "adjustable" insulators. Adjustable knobs and cleats are most commonly made of two parts which are not reversible.

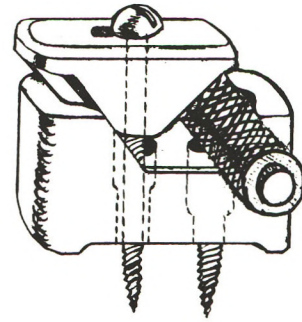

Crossover Insulators.

Any insulator which insulates one conductor from another at points where they cross. Some styles, such as the one pictured, accommodate single conductors which cross. Other forms can accommodate crossed pairs with one insulator. "Crossover Tubes" serve the same purpose. Some styles require detents, bent conductors or rigid mounting to secure the insulator, but several styles are self-retained by the conductors.

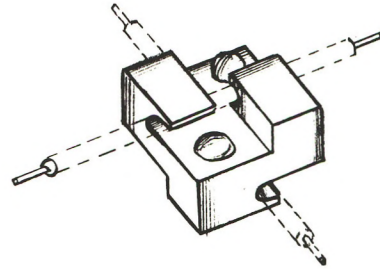

Telephone Knobs.

One-, two- and four-groove knobs generally 1-5/8" diameter with 7/16" mounting hole. Used to terminate telephone service loops, mounted on swinging brackets, angle fixtures, brackets, or simple studs and lag screws.

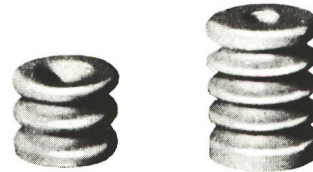

Forestry Insulators.

Split knobs (usually keyed mating surfaces) used as tree insulators. A binding wire holds the two pieces together and also attaches the insulator to the tree. The conductor is run slack-wire through the insulator hole. Solid forestry insulators (round or oval) are also used, but the conductor must be threaded through each insulator. The split styles also facilitate replacement of broken insulators without cutting the conductor.



Standard Two-wire Cleat.

As pictured here, the Standard Porcelain #334 cleat as used for house wiring. The very early versions were not reversible, but all later versions were. Sold also as Standards with tall bases and or caps, and also with a third conductor groove at the center of the cleat.

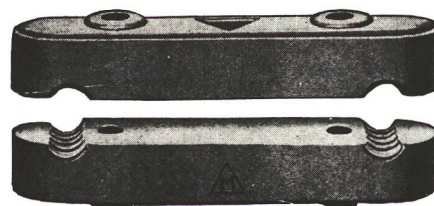

Standard One-wire Cleat.

Generally just as illustrated here, but also with optional bases and or caps of taller size. Used for securing larger conductors, as in industrial wiring. The standard sizes #1 through #9 fit conductors from rather small to extremely large.

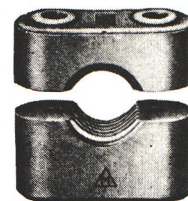

"B & D" One-wire Cleat.

Reversible cleats with a positive insulation barrier between the conductor and mounting screws, and which also serves to register the two parts. Based on the "Buffinton & Dow" 8-13-95 patent and later patented improvements and variations (see Chapter 6). Made by most standard porcelain manufacturers under license, B & D Cleats were possibly used more extensively than ordinary one-wire cleats. The patented feature was also used in other forms of reversible cleats and for split knobs (1907 patent), all manufactured under license from Buffinton & Dow.

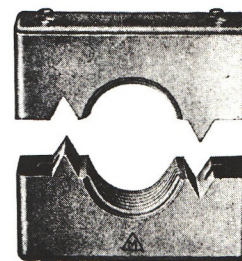

Telephone Cleat.

As illustrated here, the most widely used porcelain cleat for securing regular twin-wire telephone service connections. When used for a single leadin, a short stub of twin-wire is placed in the unused groove to prevent cocking of the cap when it is tightened down. Several other forms of porcelain nonreversible phone cleats were also made (see preceding catalog pages).

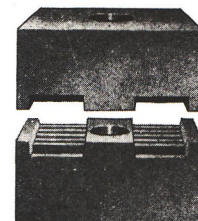

Wall Tubes.

For insulating conductors run through wall studs, rafters, etc. See catalog pages for illustrations of variations in styles manufactured.



Battery Bushing.

Distinguishable from wall tubes by the boxy heads and tube bodies which are generally slightly tapered. These bushings are usually of relatively small diameter and with bodies shorter than 1".

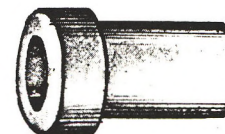

Hole Bushing.

Primarily used for outlet and switch boxes, but also for insulating conductors through any metal panels -- signs, sheet metal buildings, etc.



End Outlet Bushing.

Used as caps on outlet boxes used with conduited wires. Generally of uniform rectangular size, they come with one to four wire outlet holes. Irregular shapes are usually for use as "service entrance bushings" (weather heads) and usually have holes for 3 or 4 conductors.

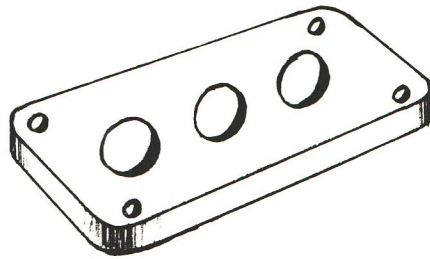

Cutout Base.

Used for mounting line fuses. The earliest ones were simply terminal blocks for inserting fuse wire. Later ones used clips for cartridge fuses (top illustration) or sockets for plug fuses (bottom). Cutout bases are sometimes combined in a single porcelain block with a knife switch. Sometimes mounted openly, but usually mounted inside metal entrance boxes.

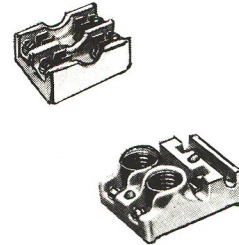

Rosette.

Mounted on room ceilings and used for terminating pendent cords for suspended switches and lamp sockets. The one on the left is for cleat wiring; the one on the right is for concealed wiring. A "fused rosette" is one with interior terminals for a fuse wire.

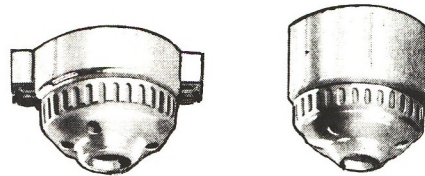

Box Type Rosette.

For suspending pendent cords from the ceiling when the feed wires terminate in conduit outlet box flush with the ceiling surface.

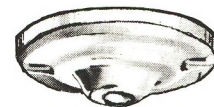

Ceiling Button.

For use when twin-wire cord run along the ceiling is dropped at its end to a pendent fixture. The one illustrated at the right is self-tying; the cord is run into the slot at A, out of the hole B, back into the slot at C, and finally out the pendent wire hole D.

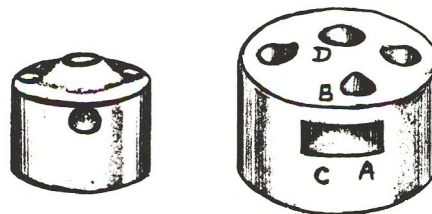

Pendent Socket.

A socket mounted on a pendent cord which hangs from the ceiling from a rosette or ceiling button. In the most common wiring systems, the on-off switch was incorporated in the socket. The switch illustrated here is the "push" type. "Key" switches were activated by turning the protruding key, and "pull chain" switches by pulling the chain.



Pendent Switch.

When light fixtures were located on the ceiling out of easy reach, the on-off switch was suspended on a pendent cord where it could be easily reached. Pendent switches were usually always the "push" variety as illustrated here, but key and pull chain types were also sold.

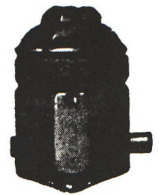

Rotary Switch.

Originally used with the first wiring systems in the 1880's, the porcelain ones were used for many years in all applications where the switch was wall mounted instead of being part of a pendent item. Some types had porcelain caps, others metal caps. Varieties exist which have a window in the cap part to show the word "ON" or "OFF" from an interior rotating plate.

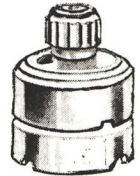

Current Tap.

An adaptor which mounts in a socket and provides an additional socket(s) plus a receptacle for another attachment plug. Box-mounted sockets and fixtures with auxillary outlet taps are properly termed "socket with current tap". Devices with plugs that fit outlet receptacles or socket adaptors and which provide a socket plus an outlet are also termed "current taps".

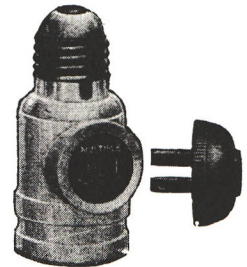

Wireholder.

Generally as illustrated here, but the variety is endless. The porcelain part can have many forms, but generally has only one rather large hole for tying on the conductor. Some versions have metal base caps, reinforcing metal sides and cross pins above the hole, etc. The attaching element is usually a lag screw as illustrated, but they are also made with threaded studs, toggle bolts, brackets for pipe mounting, etc. Some versions for street light applications have petticoated bases.

The most common size (shown here) is for terminating secondary house services. A larger size is used at times as a "primary wireholder" on crossarms at transformers. A very small size is occasionally used to terminate radio antenna wires and is called a "radio wireholder". Some versions for use as tree insulators have a removable pin across the top instead of just the porcelain hole -- this to allow stringing of the wires after the insulators are installed.



Insulated Screweye.

Used as a standoff in running radio antennas. The small porcelain knob used is usually a #45 standard porcelain knob. Made with all lengths of screw, stubby to very long.



Emily Knob.

A heavy duty screweye insulator with the porcelain knob tightly retained with the knurled metal part. Universally termed "Emily Knob", but all my re-search hasn't uncovered the origin of this name.

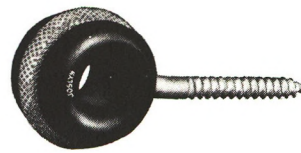

Bridle Ring Insulator.

Used for running twin-wire telephone service wires. The wires may be installed through the diagonal slot without running them through. Also used for industrial low-voltage wiring where the wires need not be secured tightly, and especially for running temporary wiring.

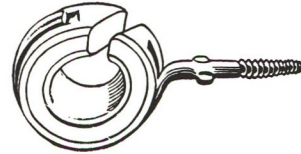

Sign Insulators.

Illustrated are examples of some of many forms of insulators used in neon signs for securing the wiring and neon tubes. The eared type standoff with spring wire mounting piece (also made in glass) is for mounting the neon tubing in signs.

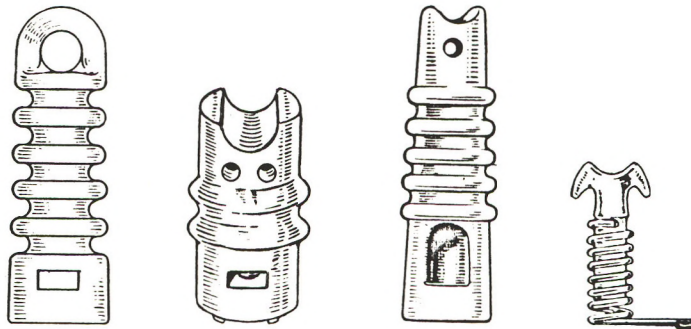

Sign Receptacle.

As illustrated here, a common socket form for mounting in punched holes in metal signs, for use with regular-sized bulbs with candelabra bases.



Radio Antenna Strain.

For insulating the ends of radio antenna wires. As made by various companies, there are many forms (both glass and porcelain), but they are generally of this banded form.



Radio Antenna Lightning Arrestors.

For lightning protection of radio antennas. Various antenna insulators were sold singly, but generally were parts of "antenna kits" sold by radio companies, mail order houses and wire manufacturers. The strains, nail knobs and arrestors in these kits had blue brown, green or black glazes.



Dead End Shackle.

A special form of clevis insulator designed for deadending communications circuits on pole lines. The clevis surrounds the cross-arm to withstand the deadend pull. Usually uses a skirted spool (also made in glass) to afford a higher insulation resistance wet.

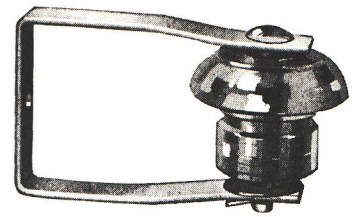

Insulated Clevis.

Used for deadending secondary power circuits. A simple form is illustrated, and there are many variations, such as ones with swing-out spool pins for inserting the conductor. These are also made with nonsymmetrical clevises for deadending at nonperpendicular angles.

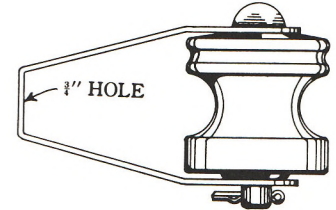

Insulated Fork.

Generally used for span-wire supports, these are made with mounting bolts as illustrated and with lag screws for mounting.

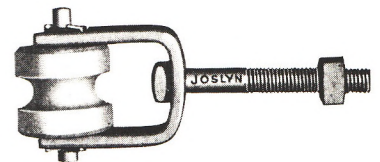

Swinging Bracket.

A form of insulated clevis used for deadending service drops at the pole end. It is fastened by a nut to the single-spool bracket, and will swing freely to any deadending angle.

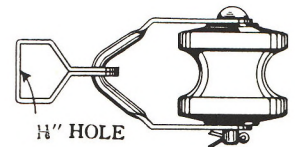

Swinging Knob Wireholder.

For deadending service drops at the house end of the drop, and at any angle. The base generally is supplied with a lag screw as illustrated.

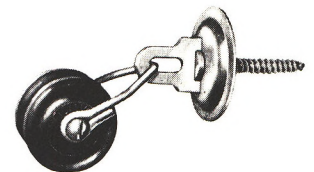

C. B. Knob.

Used for telephone drop wires to buildings and allows for any angle of support and for any swinging movement of the drop wires. It is secured to the building with an ordinary, uninsulated bridle ring mounting.

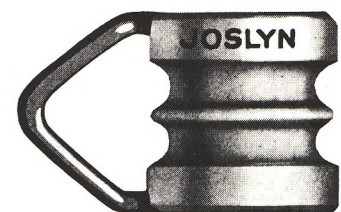

Angle Screw Fixture.

Used for telephone drop wires, either at the pole or at the building. Can accommodate various angles of pull by rotating the screw to various angles. The angle screw and insulator are generally cataloged as separate items and are ordered separately.

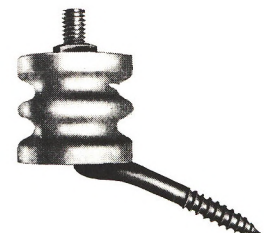

Secondary Rack.

A metallic rack with a long through-bolt, made to mount a number of porcelain spools, generally 3 or 4 in number. Used to run secondary feeders from one pole to another and to deadend secondary services at the pole and the house. The racks vary in construction from one manufacturer to another but generally approximate the illustration here. The steel foundries or poleline hardware companies procure the rack spools from various porcelain manufacturers.

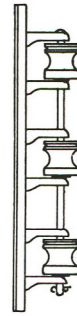

Secondary Rack Spool.

Standardized 3" spools for use with secondary racks as shown above. The great majority are this standard size and shape, but there are varieties as to size, groove sizes and number of grooves. Most rack spools are now made by wet process, but they were generally also available in dry process in times past.

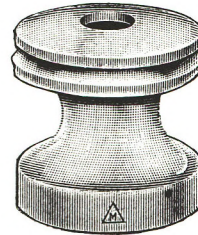

Wireholder Rack.

Used in the same way as Secondary Racks shown above. Since there is great variety of wireholders among various manufacturers, there is also a great variety of these racks.

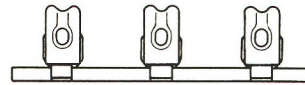

Clamp Insulator.

Any form of insulator in which the porcelain insulating elements are clamped around wire(s) by metallic structures. The illustration shows a pipe-mounting clamp insulator for one conductor. Many forms of clamp insulators use reversible split knobs as in the illustration here, but some use split insulators resembling conventional one-wire cleats. There is a very large variety of clamp insulators as made by many companies over a long period of time.

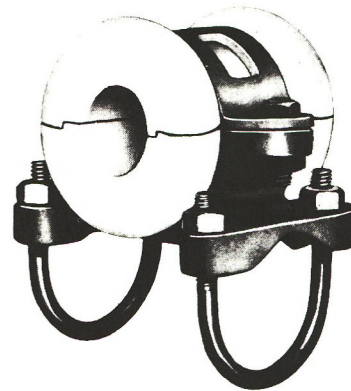

Cable Rack Insulator.

Insulator saddles which sit upon or slide onto the horizontal members of cable racks and which support any heavy cable. Such racks are found in industrial applications and in mains run under streets, accessible through man holes.



Strain, Closed-end.

An insulator used to break the electrical path in any wire link, such as in guy wires used to support utility poles. Closed-end strains have holes through which the link wires must be threaded during their installation.

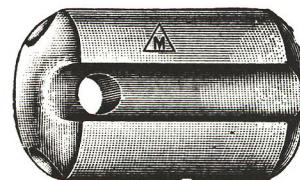

Strain, Open-end.

Used for the same purpose as closed-end strains. The ones oval in cross section are sometimes referred to as "egg" strains. Note that all strain insulators other than radio antenna strains are fail-safe mechanically in that the end wires are still coupled even if the insulator is shattered.

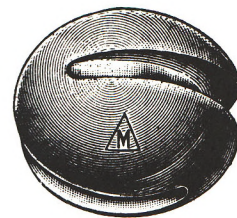

Break Knob.

Small, open-end strain insulators used to break continuous circuits as when devices are operated in series from a continuing circuit. The knob illustrated was designed for this use in the 1890 period as was the "Bain Break Knob" (Standard Porcelain knob #35). Needless to say, any strain insulator can similarly be used as a break knob, and many are still in use as such on series street light circuits.

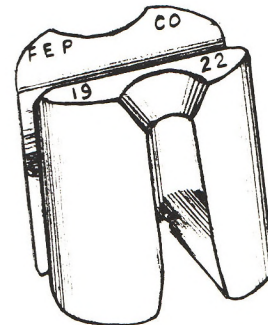

Pin Type Insulator.

Insulators which are for use on regular crossarm pins. Made in many styles and sizes for varying purposes. The small telephone types and some low-voltage distribution types were made by both wet and dry process. The larger types for high voltage were made only by wet process.

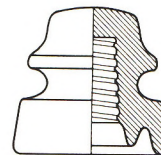

Primary Fuse Cutout.

Used to fuse the primary circuit of distribution transformers -- and usually mounted directly on the crossarm adjacent to the transformer. Also referred to by other names such as "Plug Type Fuse Cutouts". Styles vary from different manufacturers and with vintage, but all have the removable bottom plug which has terminals for a renewable fuse wire. Markings are those of the porcelain manufacturers, transformer manufacturers or poleline hardware companies.

These cutouts have been obsolete for many years. In modern methods, the primary circuit is protected by a link fuse mounted in spring clips across the associated lightning arrestor, and these can be easily replaced from the ground by a telescopic, insulated pole.

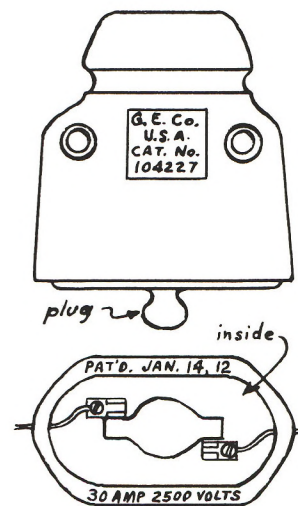

Chapter 3

MANUFACTURING METHODS

THE NATURE OF ELECTRICAL PORCELAIN

The prime constituents of electrical porcelain are flint, feldspar, ball clays and china clay (Kaolin). Additionally, aluminum oxide (Alumina) is substituted for some or all of the flint to obtain stronger porcelain bodies. Glaze formulas are similar to that of the body material except for an increase in glass-forming and fluxing ingredients. All of the raw materials for porcelain insulators must be carefully selected for quality and mixed in exacting quantities.

Each of the constituents performs a function of its own or complements the work of one of the other materials. The ball clays impart the plasticity in the soft working state of porcelain and give the material strength in its dry, unfired condition. The Kaolin controls stability during the firing process by reducing the tendency toward warpage. The feldspars are the glass formers during the firing process, although the clays and flint also participate. The flint partly dissolves during the firing process, and a strong bond is created between the remaining core of the flint crystals and the surrounding glass. The completely vitrified porcelain body can be visualized as a microscopic crystalline structure completely bonded together with glass. Even though the end product is approximately 65 percent glass, it is chemically and structurally entirely different from ordinary commercial glass.

PREPARATION OF THE CLAYS

The following brief description applies to any large manufacturer of quality porcelain insulators, but not necessarily to the very small operators who entered the picture during the nail knob boom years. The small manufacturer sometimes paid little attention to proper procedures for the mixing of ingredients, preparation of clays and firing of the ware. When this was the case, the finished insulators were of poor quality.

Clay batches are made by mixing carefully weighed quantities of each ingredient with a precise amount of water, and also by recycling "scrap" clay recovered from trimming and turning operations. The batch is thoroughly mixed until all clay particles are broken down, and the result is a mixture with a consistency approximating that of heavy cream -- called "slip". The slip is processed through a number of screen filters at various stages, passes over a magnetic filter to remove iron particles and then goes to a vacuum tank where all possible air is removed from it. It is then pumped into filter presses where the water content is reduced to about 22%, and we now have plastic clay for the first time. This "green" clay is used for the manufacture of porcelain items by the plastic or wet process.

To further prepare the clay for manufacturing porcelain items by the dry process, it is dried until the moisture content is reduced to about 12 percent. This clay is then granulated by various methods to yield small particles about the size of coffee grounds. The material is somewhat similar in action to snow; it can be manipulated around in loose form, but it is just wet enough to permit it to "ball" under pressure.

GLAZING

With several exceptions, essentially all standard porcelain insulators were glazed, and the standard glaze color was white. Ordinary wall tubes were nearly always made unglazed. Nail knobs and surface wiring cleats for house wiring were made both ways, glazed and unglazed. Glazes other than white were generally used on radio antenna insulators.

The glaze on standard porcelain not only made the insulators have a more finished appearance, but it served a mechanical and electrical purpose as well. It served to reduce insulation abrasion on the conductors, and since porcelain insulators made by the dry process have some degree of porosity, the glaze assisted in maintaining insulation resistance when the insulator was used outdoors. Glazed insulators were much less prone to the accumulation of dirt and various contaminants.

The glaze slip can be applied to the dried insulator bodies by several means, but it was nearly always done by dipping or spraying-on. One surface of the insulator was selected as the firing surface and was left unglazed to prevent the item from welding itself to the sager when it was fired. For many years, it was common practice to just glaze the entire insulator and then, after drying but before firing, to fettle off the unwanted glaze from the intended firing surface. Commencing about 1920, it became general practice to use a glaze-resist method wherein the firing surface was dipped in molten paraffin before dipping in the glaze bath. The glaze slip would then not be applied to the paraffined area, and the paraffin would quickly burn away when the insulator was fired.

Some of the larger standard porcelain knobs (spools) were fabricated by die-pressing identical half-knobs and then glazewelding the two halves together. Likewise, some difficult special porcelain shapes not easily makable in a single pressing operation were made by glazewelding two or more parts together. The mating surfaces to be glazewelded are both dipped in glaze and fitted together. The parts are then fused together when the item is fired.

KILN FIRING

Except for the larger companies operating in relatively more recent times, standard porcelain was fired in periodic kilns, most generally of the "beehive" type. The ware to be fired were arranged inside ceramic sagers which were then loaded into the kiln, utilizing the maximum amount of space inside the kiln. Electrical porcelain was fired at 2200 degrees Fahrenheit. The temperature was raised slowly to this temperature, maintained there for approximately 5 hours duration, then allowed to slowly descend to room temperature.

The periodic kilns used in the electrical porcelain industry burned coal as a fuel for many years, and at least one company still uses coal as the fuel. Some kilns were fired by oil or natural gas commencing in the 1920's, and this was coincident with the introduction of "continuous" kilns by some of the larger companies. The ware was loaded on kiln cars which slowly moved through a tunnel kiln on tracks. The kiln temperature increased progressively towards the center of the tunnel at the firing zone and then decreased progressively toward the exit end of the tunnel.

Firing any ceramic objects is not only an exacting task, but it also involved a certain amount of luck with the crude kiln equipment used by some small companies during the nail knob boom times. Even perfectly

pressed insulators could be ruined by imperfect firing, and many times an entire kiln load of fired ware had to be discarded. Additionally, insulators could be made from imperfect clay batches or on improperly adjusted press setups for days, or even weeks, before the problem became apparent weeks later when the imperfect items were fired. The scrappage rate of fired insulators was at times very high, and the porcelain dumps at some of the old porcelain plants certainly attest to this. At one porcelain plant in Ohio, the factory building occupies about 1 acre of ground; the porcelain dumpage occupies the other 4 acres of the property.

THE "WET PROCESS"

Generally the term "wet process" refers to insulators made from clay in the plastic state. Properly made wet process insulators are superior to those made by the "dry process" in that they have zero porosity. Most standard porcelain insulators were made by the dry process, but some were made by wet process, and this was only because it was easier to do it in that manner. All insulators made for high voltage work are made by the wet process due to its superior insulating qualities.

In the wet process, the clay is used just as it comes from the filter presses -- approximately 22% moisture content. Insulators are made by pressing or extruding the plastic clay to the desired shape.

All forms of insulating tubes were made by wet process. The lengths of tube were made by continuous extrusion of clay through appropriate die sizes and the tubes cut to appropriate length. The tubes were "headed", split or curved in separate operations. Needless to say, it would have been virtually impossible to make very long tubes by any pressing operation of plastic clays or by any type of dry process operation.

Technically speaking, the term "wet process" includes items made by casting of clay slip in plaster molds. This process is sometimes used to produce difficult porcelain shapes where dry process quality is not good enough for the intended use -- as in high voltage insulators. Very few insulators are made by casting, and none of the standard porcelain or specialty insulators covered by this history was made by casting.

THE "DRY PROCESS"

For reasons which will become obvious later, insulators made by this process are also referred to as "dry press" insulators. The dry process is well adapted to the manufacture of difficult porcelain shapes that can not be made by the ordinary wet (plastic) process. It has the disadvantage that the end product is porous to varying degrees, and this rules out dry press insulators for any kind of high voltage work. The porosity of dry process porcelain is of little consequence in low voltage insulators, and that is the case for all standard porcelain and over-surface wiring insulators covered in this history.

As described under "Preparation of the Clays", the plastic clay is further dried to a 12% moisture content and is then granulated for use in the dry process.

Dry process porcelain items are made in very simple screw press setups. The dies are mounted with the top opening flush with a table surf-

ace, and a screw-press ram is operated directly above the dies. A supply of the clay granules is fed to the working surface. The operator simply pulls a quantity of the granules over the die opening, strikes off the excess flush with the top of the die and operates the press ram to form the insulator. Better compacting is achieved if the pressure is released once and reapplied a second time. After fully reversing the press screw to retract the top ram die, the finished piece is ejected from the die cylinder by depressing a foot lever which raises the bottom element of the die set to the top of the die cylinder. The entire operation takes only a few seconds per piece.

The pressed insulators are placed in rows on greenware boards which are placed in movable rack carts. After the pieces have thoroughly air dried, any excessive mold lines are removed before the pieces are glazed and fired. Defective pieces are returned to the clay processing area.

Needless to say, different die sets are required for each different type of insulator made. Most standard porcelain items are very simple in shape and require simple die sets, but specialty porcelain sometimes required very complicated die sets. Any company which made a complete line of standard porcelain (and possibly also specialty porcelain) necessarily employed one or more tool and die makers to make all the tooling.

Objects with vertical sides required relatively simple die sets consisting of a bottom ram and top ram which fit a vertical cavity of the same cross section. Objects with nonvertical sides required parting-type side dies in addition to the ram dies. For instance, a simple item such as a wireholder required a die set having at least 4 elements. In some cases, items with holes not aligned with the direction of the press ram motion were made without holes, and the holes were drilled (wet) after the piece was removed from the press.

Various insulators were made in any manner which proved to be most economical from the standpoint of operator time and die preparation cost. An ordinary solid knob could be made in a single press operation with a four-piece die set -- side dies being required because of the side groove in the knob. But this was the hard way. It required a pair of parting-type side dies, and which the operator had to insert in the die cylinder for each piece made, and it required that all pieces have the mold lines fettled off after they were dry. Consequently, it was general practice to make solid knobs without the side groove(s) in the dry press and then form the grooves in a trimming operation. This not only eliminated the need for parting-type side dies, but it made it possible to press with the same ram dies any knobs which had the same overall diameter and same hole diameter. The knob length was easily varied by adjusting the height of the bottom ram die in the press.

DIE MARKINGS

The majority of electrical porcelain items carry some form of marking -- standard porcelain size number, catalog number, company name or trademark, patent dates, etc. Except for isolated instances noted below, the markings are always in embossed (raised) letters and numerals and is always on the top or bottom surface of the piece in relation to the press forming direction. Once the marking is added to the press dies, nothing more need be done to mark the pieces. Any marking on the dies is faithfully reproduced on every piece made in that die. Manufacturers used two methods for adding the marking to dies, and each will be explained.

The first method was to simply stamp the letters and numerals into the surfaces of the die, and this results in the insulator having marking characters embossed above the surface of the insulator. We call this an "embossed" marking. The die marking is permanent in that it cannot later be changed without brazing in the old marking and repunching with the new marking. This type of marking was generally used only on dies for stock insulators of the porcelain manufacturer and dies owned by customers for making their proprietary items.

The second method was to first stamp the marking on a piece of thin brass stock and then solder this to the die surface. The result was an embossed marking on a recessed surface of the insulator, and we call this a "recess-embossed" marking. One advantage of this marking method was to be able to mark insulators without the marking interfering mechanically in some way, such as when mating surfaces of split knobs are marked. The main advantage was that the marking could be changed quickly and easily by merely removing the brass strip and replacing it with one marked differently. This was the case when a porcelain manufacturer received orders for insulators to be marked with the customer's own tradename or catalog numbers. Also, when the porcelain manufacturer was making an insulator run with special dies furnished by the customer, he could easily add his own identifying mark to the dies and remove it after the run and before returning the dies to the customer.

In either of the above two methods, a set of "reversed" letter and numeral punches were required. The confusion between the regular and the reversed punches led to some errors in markings wherein one or more letters or numerals in the marking are reversed (mirror image).

Underglaze markings are inkpads stamp markings applied to porcelain bodies before glazing and which show through the glaze upon firing. Some very early knobs made by Union Porcelain Works were marked in this manner and Specialty Porcelain Works also used underglaze markings on specialty electrical porcelain insulators.

Illinois Electric Porcelain Company is known to have marked standard porcelain items with a handstamp device of their Triangle-M trademark as an interim measure before markings on dry press dies were changed from the MACOMB marking to the newer Triangle-M marking. These specimens bear both the embossed MACOMB marking and the handstamped Triangle-M marking.

Chapter 4

ELECTRICAL PORCELAIN MANUFACTURERS

ACME PORCELAIN COMPANY

Listed by one reference as having operated on Breuning Ave, Trenton, N.J. (dates not mentioned). No other information.

ADAMANT PORCELAIN COMPANY

The plant was located on the north side of West 6th Street in East Liverpool, Ohio. One reference indicated "on West 7th Street". Plant history was as follows:

1907	Adamant Porcelain Co.	Electrical porcelain
1912	" " "	Sanitary ware
1915	T. V. Milligan Porcelain Co.	Electrical porcelain
1929	Peach Porcelain Co.	" "
1932	Ceramic Specialties Co.	" "
1955	(Defunct)	

Adamant Porcelain Co. was organized in 1907 by J. C. McQuilken, W.J. Gurry, W. A. and T. J. Andrews. It made electrical porcelain initially but was refitted for the manufacture of sanitary ware in 1912. The plant was closed the following year. (See American Porcelain Co., E. Liverpool for more information on this group of people.)

Shortly afterwards, the idle plant was purchased by Harry Peach and George Ried, both formerly of East Liverpool Electrical Porcelain Co. (q.v.), and electrical porcelain was once again manufactured. The name of the company was T. V. Milligan Porcelain Co., and the product was sold under the "Adamant" name. The plant was destroyed by fire during World War I and was subsequently rebuilt on a larger scale.

Mr. Milligan left the company in 1929 and bought the idle Ravenswood Porcelain Co. plant (W. Va.) from General Porcelain Co. The name of the Adamant Porcelain Co. plant was then changed to Peach Porcelain Co.

In 1932 Ceramic Specialties Co. commenced operations at this plant, either through name change or change of ownership, and the manufacture of electrical porcelain was continued. The plant became defunct in about 1955 and is now the site of a hospital. All former plant dumpage is now over-covered by the new buildings.

The Barth Museum (East Liverpool Carnegie Library) contains a small display of products of Ceramic Specialties Co. including wall tubes, RACO deadend, rack spools, wireholders, a distribution pin type, and solid knobs (with an embossed Circle-G marking). Electrical industry directories indicated Adamant used "HOLD FAST" as a tradename for split knobs.

AKRON HIGH-POTENTIAL PORCELAIN COMPANY

Please see page 101.

AKRON INSULATOR & MARBLE COMPANY

The plant was located at 973 Grant St., Akron, Ohio. I do not know the founding date or interim history.

Aside from manufacturing marbles, the company also made electrical porcelain. No information on the exact line is known, but a large wall tube was found with the marking "A. I. & M. CO.", and this specimen is probably a product of this company.

In 1904 the company consolidated with the Colonial Sign Company as the Colonial Sign & Insulator Co. (q.v.).

AKRON PORCELAIN COMPANY

The plant is at 2719 Cory Ave., Akron, Ohio (44314), and they manufacture special porcelain parts to customer specifications. This plant was established in 1928 as the successor to Mogadore Insulator Co. (q.v.)

AKRON SMOKING PIPE COMPANY

The old plant site was at 3775 Mogadore Road, Mogadore, Ohio. This property is now occupied by new buildings of an automobile agency, but some remnant plant dumpage is in evidence on the property.

The company was organized in 1890 by J. W. Baker, J. C. McMillen, C. H. Palmer, F. W. Butler, Sr. and Charles Baird for the manufacture of stoneware pipes with reed stems, as premiums by the Diamond Match Co.

In 1895 (one source states 1896), they also commenced the manufacture of standard wiring insulators -- tubes, knobs, cleats, etc. These were made from local stoneware clay. At some time shortly thereafter, the insulator body was changed to standard electrical porcelain, and they commenced manufacture of other insulator types also.

In 1906 the company manufactured the first third-rail insulators used in the U.S., and these went to the N.Y. Central Railroad. It also produced all of the original insulators for the West Shore Line of the same railroad.

The smoking pipe and clay novelty portion of the business was sold to a Virginia firm in 1919, and attention was thereafter devoted entirely to manufacture of standard and special electrical porcelain fittings. In April 1920 the name was changed to Mogadore Insulator Company. In 1928 a new plant was built in Akron, Ohio and the name changed once again to Akron Porcelain Company (q.v.).

Standard wiring cleats have been found with a marking "A. S. P. CO." which is attributed to Akron Smoking Pipe Co. A marking "M I CO" appeared on some specialty items at the old plant site, and this is attributed to Mogadore Insulator Co.

AMERICAN PORCELAIN COMPANY, The

This plant was located on the southeast corner of 2nd St. and Cherry Ave., East Liverpool, Ohio. The plant history is:

1845	Ball & Morris (Union Pottery)	Rockingham & Yellow
1855	McGilvary & Orr	" " "
1857	Croxall & Cartwright	" " "
1914	American Porcelain Company	Electrical porcelain
1932	(Operations suspended)	

American Porcelain Co. was founded in 1914 with the purchase of the factory of Croxall Pottery Co. and also that of G. W. Croxall & Sons. The product was changed from tableware to electrical porcelain.

The founders consisted of W. J. Curry, W. A. and T. J. Andrews, all formerly owners of Adamant Porcelain Co. (1907-1915) in East Liverpool. These men were also officers of Ohio Porcelain Co., East Liverpool, and which was bought by General Porcelain Co. in 1913.

Some dumpage remnants remain at the old plant site, including standard porcelain cleats and knobs, variously marked "AMERICAN" and circle-AP. A U-98 pin type mine insulator was also found in the area, and with a customer marking, "COOKE WILSON E. S. CO.". A 1921 electrical industry directory listed American Porcelain Co. with companies manufacturing pin type insulators, but no regular pin types have been located which can be attributed to American other than the U-98 mentioned above.

AMERICAN PORCELAIN COMPANY (Trenton, N.J.)

A solitary reference lists an American Porcelain Company as having operated on Breuning Ave., Trenton, N.J. in 1895. I have no other information and do not know if the company manufactured electrical porcelain.

ANDERSON PORCELAIN COMPANY

This plant was located on the south side of Harvey Avenue between Myrtle and Putnam Streets, East Liverpool, Ohio. Plant history was:

1900	Anderson Porcelain Co.	Electrical porcelain
1911	General Porcelain Co.	" "
1916	Louthan Manufacturing Co.	Elec. porc. & Gas porcelain

The factory was built and production started in 1900. Officers were T. F. Anderson (Pres), T. B. Anderson (V.P.), G. O. Anderson (Ses-Treas). In the beginning, only tubes, cleats and knobs were made, but in 1905 a line of pin type and strain insulators was added.

No pin types have been found which can be definitely attributed to Anderson Porcelain Co., but several specimens of knobs have been found

in the area of the old plant which have a marking "A. P. Co.". Several very large wall tubes have been located which are prominently marked "THE ANDERSON PORCELAIN CO. / EAST LIVERPOOL, O."

The plant was bought by (merged into) General Porcelain Company in 1911. When G. P. Co. built their large new plant in Parkersburg, W. Va. in 1913, all its other plants (except Carey, Ohio) were dismantled and the equipment sent to Parkersburg or Carey. This old facility was sold by G. P. Co. to Louthan Mfg. Co. in 1916 (formerly Louthan Supply Co. until 1916). Louthan moved all their facilities to the Klondyke area in 1922. This is an area just east of East Liverpool proper.

George O. Anderson remained with General Porcelain Company after the 1911 merger and subsequent sale of this East Liverpool plant, and he re-located in Parkersburg with G. P. Co. He left this company after the 1927 Porcelain Products Co., Inc. merger and bought the idle electrical porcelain plant in New Haven, W. Va., renamed Superior Porcelain Co. by Anderson (q.v.).

T. F. Anderson later utilized the abandoned George F. Brunt Company plant (E. Liverpool) for the General Electric Co. and also the adjacent Riverside Knob Works.

BAY RIDGE SPECIALTY SHOP

Originally located at 682 Stokes Ave., established 1915. Specialized in electrical porcelain items, but I do not know if they manufactured "standard porcelain" items.

Currently, Bay Ridge Specialty Company, Div. of Star Porcelain Co., 96 Stokes Ave., Trenton, N.J. (08638). Manufactures whiteware, both cast and pressed porcelain specialties, such as bath accessories and artware. No information as to possible manufacture of electrical items currently.

BOCH, JOHN (Porcelain Co.)

John W. Boch, Sr. was a ceramics expert with the R. Thomas & Sons Company for many years. He left Thomas in 1907 and was succeeded there by his son, John W. Boch, Jr.

John W. Boch, Sr. then formed his own company for the manufacture of electrical porcelain. The plant was located at the northeast end of 6th Street, Newell, W. Va. I do not know if he made any "standard porcelain" insulators there, nor of any insulator markings that can be attributed to that company. Its history was:

1907	John Boch	Electrical porcelain
1937	(Moved to Klondyke)	

In 1937 he bought another facility in East Liverpool (Klondyke area) and the name became Specialty Porcelain Works. Its location was the west

side of Pearl Street at Michigan & Elizabeth Sts. Its history was:

1895	French China Co.	Semiporcelain
1901	Smith-Phillips China Co.	"
1929	Amer. Chinaware Corp., Plant F	"
1931	Johnson China Co.	Porcelain & Semiporcelain
1937	Specialty Porcelain Works (Boch)	Electrical porcelain
1973	(In operation)	

I have no information on possible non-specialty insulators made by this company in recent years, but they did make standard porcelain insulators at one time. Markings used on standard wiring cleats & knobs were "SPW" and "S.P.W.". Their marking used on at least some specialty porcelain insulators was "S. P. W'KS".

John Boch, Sr. was also involved in the founding of another electrical porcelain company (see Metsch Refractories Co.).

BOGH-METSCH PORCELAIN COMPANY

See "Metsch Refractories, Inc.".

BRUNT PORCELAIN COMPANY, G. F.

This small plant was located on the west side of Market St. at 1st Street in East Liverpool, Ohio. Its early history to its entry into the electrical porcelain market is as follows:

1847	William Brunt, Sr.	Rockingham, Yellow & Knobs
1852	Wm Brunt & Wm Bloor (partners)	" " " "
1853	William Brunt, Sr.	" " " "
1881	Riverside Knob Works (Henry Brunt & Son)	Clay and porcelain knobs
1891	" " "	Electrical porcelain also

William Brunt, Sr. built the pottery in 1847 for the manufacture of Rockingham, Yellow and door knobs. It was operated as a family company except during 1852-53 when a partnership resulted in the name "William Brunt & William Bloor". Henry Brunt was the son of William Brunt, Sr.

In 1891 Henry Brunt & Son began manufacturing electrical porcelain (cleats, knobs, tubes, etc.), and a separate building was soon thereafter constructed next door on the same property to handle this business. In 1894 they developed once-fire electrical porcelain, which process thereafter came into general use by other electrical porcelain companies.

In 1895 Henry Brunt retired. The door knob part of the business was taken over by his son, William H. Brunt, and operated as Riverside Knob

Works. The electrical porcelain part was taken over by his other son, George F. Brunt and, in partnership with a Charles F. Thompson, was operated under the name "Brunt & Thompson".

The ensuing history of the door knob part of the business was:

1895	Riverside Knob Works (Wm H. Brunt)	Knobs
1917	General Porcelain Co.	Electrical porcelain
19??	Operations suspended	
19??	G. E. Co. (by T. F. Anderson)	Electrical porcelain
1930	Riverside Knob Co. (John C. Miller)	Knobs
19??	Abandoned	

The ensuing history of the electrical porcelain part was:

1895	Brunt (G.F.) & Thompson	Electrical porcelain
1897	G. F. Brunt Porcelain Co.	" "
1911	General Porcelain Co.	" "
19??	G. E. Co. (by T.F. Anderson)	" "
1930	Riverside Knob Co. (Miller)	Knobs
19??	Abandoned	

George F. Brunt had bought out Thompson's interest in 1897 and continued the business under the name "G. F. Brunt Porcelain Company" until it was purchased (merged into) in 1911 by General Porcelain Company headquartered in Parkersburg, W. Va.

General Porcelain Co. also bought the adjacent Riverside Knob Works in 1917 and operated both facilities as one making electrical porcelain there until abandoning the plants in the early 1920's. The plants were leased by General Electric Company and operated by T.F. Anderson for them subsequently. In 1930 the property was bought by John C. Miller and once again made furniture/door knobs as Riverside Knob Co. for several more years. The plant is now defunct.

In 1914 George F. Brunt and others organized the Brunt Porcelain Co. in Columbus, Ohio (q.v.).

During the brief two-year span when the East Liverpool company was operating under the name Brunt & Thompson, they are known to have used a marking "B & T" on some specialty electrical porcelain items.

Otherwise, the common marking used for many years by Brunt in his various operations was "BRUNT". After General Porcelain Co. bought the East Liverpool company, they continued using BRUNT dies (especially those for specialty items) at the Parkersburg plant thereafter. Therefore, a "BRUNT" marking on any item is not necessarily an indication of early manufacture of the item.

Brunt used a tradename "CINCH" on split knobs (nail knobs), and this marking is found on knobs together with the "BRUNT" marking.

BRUNT & THOMPSON

The operating name from 1895 to 1897 of George F. Brunt's porcelain plant in East Liverpool, Ohio. For details, see "BRUNT PORCELAIN CO., G. F." above.

BRUNT PORCELAIN COMPANY

This plant was located in Worthington, Ohio, a northern suburb of Columbus, and its history is as follows:

1914	Brunt Tile & Porcelain Co.	Tile & Electrical porcelain
1920	Brunt Porcelain Co.	Electrical porcelain
1925	(Business abandoned)	

George Brunt had sold his East Liverpool electrical porcelain plant to General Porcelain Co. in 1911. Then in 1914 he and others organized Brunt Tile & Porcelain Co., buying a chinaware pottery (history not recorded above) in North Columbus for this purpose. The officers consisted of George F. Brunt (Pres.), H. D. Clark (V.P.), J. T. Herbert (Secretary) and W. F. Steele (Treasurer and General Manager).

The chinaware plant was enlarged and refitted for the production of electrical porcelain and mosaic tiling. Both kinds of ware were made until 1920, after which the mosaic tile line was dropped. The electrical porcelain output was tubes, cleats, knobs and specialty items.

The business was abandoned in 1925 and the plant sold.

BRUNT TILE & PORCELAIN COMPANY

See "Brunt Porcelain Company" above.

CAREY OHIO PORCELAIN COMPANY

This is one of three electrical porcelain plants located in Carey, Ohio, and little is known of its operation. It was constructed in 1921 and was located adjacent to the main line railroad tracks. It is now defunct and the site of an automobile wrecking and salvage yard.

There was considerable porcelain scrap lying about the property. It indicated the company made both standard porcelain insulators and specialty items. Markings of "C. O. P." and "CAREY / OHIO" were found on specimens at the plant site.

CENTRAL PORCELAIN COMPANY

Listed by one reference as having been in business at Pennsylvania & New York Aves., Trenton, N. J. in 1906, and which became the Electric Co. and then the Whitehead Company. No other information.

It is not known if this was a manufacturing company and, if so, if they manufactured electrical porcelain insulators.

CERAMIC INSULATOR CORP.

Located at 145 Caldwell Drive, Cincinnati, Ohio (45215). Manufactures wet process electrical porcelain for transformer bushings, cutouts, arrestors, buss insulators, capacitors and specialty porcelain for electrical equipment manufacturers. No other information. I do not know if this company ever made dry press electrical porcelain.

CERAMIC SPECIALTIES COMPANY

Located 1932-1955 in East Liverpool, Ohio. Please see the listing under "Adamant Porcelain Company".

CHANCE COMPANY, A. B.

For details, please refer to "Porcelain Products, Inc.".

CINCINNATI PORCELAIN COMPANY

This plant was located at 4316 Durham Ave., Cincinnati, Ohio. In 1920 the Strobl Tile Company of Cincinnati changed its product from that of quarry tile to standard and special electrical porcelain, and the firm changed its name to Cincinnati Porcelain Company.

The company was bought by (merged into) Porcelain Products, Inc. in 1927, and operations ceased in Cincinnati. The plant site is now covered over at the old address, and no dumpage could be located.

COLONIAL SIGN & INSULATOR COMPANY

This plant was located at 973 Grant St., Akron, Ohio. In 1904 the Akron Insulator & Marble Company consolidated with the Colonial Sign Co. as the Colonial Sign & Insulator Co. with a capitol stock of \$50,000.00. After this date, the original firm ceased the manufacture of marbles and

devoted its attention exclusively to electrical porcelain.

Although the plant site is now occupied by new buildings of a large machine shop (955 Grant St.), considerable insulator dumpage remains on the periphery of the property. Standard wiring cleats were found bearing the marking "C.S.I. Co." and "C. S. & I. Co."

At some time subsequent to the 1904 founding, but prior to a listing in a 1953 directory, the company name (or insulator operation) changed to Colonial Insulator Company. Specimens in the plant dumpage also bear the name "Colonial Insulator Co." and forms of a Monogram-CI-Co. "COLONIAL" was the tradename used for knobs sold by J. H. Parker, a jobber of electrical items, but specimens so marked have not as yet been reported.

COOK POTTERY COMPANY

The plant was located at Prospect St. and P. & R. Railway, Trenton, N.J. It was established in 1897. Products included standard porcelain, many forms of specialty electrical porcelain and, in later years, many types of nonelectrical porcelain goods.

In late 1931 or early 1932, Cook Pottery Company merged with Ceramic Allied Products, Inc. to form Cook-Ceramic Company. Then on 1-23-32 this company purchased the New Brunswick porcelain manufacturing division of Circle F Mfg. Co., and the later company's manufacturing activities were transferred to the Cook plant on Prospect Street. (See also Freeman Porcelain Company.)

Cook used the marking "G. P. CO." on standard porcelain insulators, and also a tradename "WEDGE" on their patented split knobs (nail knobs). They also used a trademark Hexagon-C in their literature and packings, but this exact form has not been noted on insulator specimens. Dumpage scattered about the old plant site indicates that Cook was a "job shop" manufacturer for many other electrical companies who themselves did not manufacture the items they sold.

Sources in Trenton porcelain circles indicate Cook went out of business on Prospect Street variously from 1950 to 1960. However, Cook was still listed in registers as late as the 1970's.

CURRAN-PFEIFF CORP.

Located in Metuchen, N. J. Directory listed as a manufacturer of electrical porcelain insulators. No other information available.

DAVIDSON PORCELAIN COMPANY

The plant was located on the north side of Newell Rd. at Corporation Line, Newell, W. Va. (East Liverpool mailing address used), and its history was as follows:

1913	Davidson-Stevenson Porc. Co.	Elec. porc. & Novelties
1920	Davidson Porcelain Co., The	Electrical porcelain
1936	Operations suspended	

The company was founded in 1913 as Davidson-Stevenson Porcelain Co., Newell, W. Va. However, they also leased another pottery plant at the northeast corner of Broadway and 6th Sts. in East Liverpool, Ohio from 1913 to 1919 and manufactured electrical porcelain there. This plant reverted to Hall China Co. in 1920 (moved to Klondyke plant in 1930).

Stevenson left the picture in 1920, and the name was changed to The Davidson Porcelain Company. Officers were W. M. Davidson (Pres. and Gen. Manager), Richard B. Smith (V-P), C.C. Danielson (Sec-Treas). Operations were suspended in 1936.

Davidson Porcelain Company used the tradename "EVER READY" (at times listed as "EVEREADY") for split knobs, and they were listed in directories as the exclusive licensee for Eveready Porcelain Co., East Liverpool, Ohio. Nail knob specimens from the old plant site on 6th Street in East Liverpool bore markings "EVER READY / D. P. Co."

Earlier specimens of knobs from the East Liverpool plant site bore markings of "D & S" and "D & S P Co.", both of which stood for Davidson-Stevenson Porcelain Co.

DIAMOND PORCELAIN COMPANY

One of several companies merged in 1913 to form General Porcelain Co., Parkersburg, W. Va. (q.v.). Diamond Porcelain Co. was located in Trenton, N. J., and a Diamond marking on various standard porcelain items is probably that of this company. No other information.

DIXIE ELECTRICAL MANUFACTURING COMPANY

Located in Birmingham, Alabama (P.O. Box 6298, 35217). Listed in 1970 register as a manufacturer of various insulators including suspension types, spools, pin types. No other information.

EAGLE PORCELAIN COMPANY

Located at Princeton & Chadwick Aves., Trenton, N. J. and operating during an unknown period prior to 1930. This may have been only a sales company, especially in later years. No other information.

EAST END POTTERY COMPANY

Located in East Liverpool, Ohio 1905-1910 at the site of the Trenle plant (which see for details and dates). Wiring cleats have been found at this plant location which are marked "E. E. P. Co.".

EAST LIVERPOOL ELECTRICAL PORCELAIN COMPANY

This plant was located on the west side of Boyce St. between Maple-tree and Elmtree Sts., East Liverpool, Ohio. It was also known by the name Electrical Porcelain Company. Its history was as follows:

1903	E. Liverpool Elec. Porc. Co.	Electrical porcelain
1911	General Porcelain Co.	" "
1916	Bisque Novelty Works	Novelties, doll heads, etc.
1919	D. E. McNicol Pottery Co.	Rockingham & Yellow
1931	Trymore Clay Products Co.	" " "
1933	Bellmar Pottery Co.	" " "
1935-37	Goodwin Pottery Co.	" " "

The company was formed in 1903 by William Erlanger, George and Harry Peach, Samuel Dyke and Dr. R. J. Marshall. It produced both standard porcelain and specialty porcelain insulators as proprietary items and on contract to other electrical sales companies until absorbed by General Porcelain Company in 1911.

Only a few scattered specimens remain in remnant dumpage around the original plant building, but these confirmed markings of "E. P. Co." and "E" for this company on standard porcelain insulators.

EFFICIENCY ELECTRIC COMPANY, The

Located in East Palestine, Ohio, this may have been only a sales company and not a manufactory. Established in 1917, and the officers were John Morgan (Pres.), A. J. Wayman (V.P.), L. M. Keyes (Sec.), J. C. Chamberlain (Treas.). The company manufactured all forms of electrical line mounting equipment, including conduit and associated items.

They used "EFFICIENCY" as a tradename for porcelain cleats.
No other information.

ELECTRICAL PORCELAIN & MANUFACTURING COMPANY

Located at 309-315 Monmouth St., Trenton, N.J. Incorporated April 18, 1895 by David Crossley, F. F. and J. L. Waechter and Carl F. Adam for the manufacture of porcelain insulating devices (insulators).

An August 1895 trade journal article and cut indicate the company did make porcelain insulators such as cleats, but no specimens have been located which can be linked with this company.

Also in 1895 the company contracted with Fred M. Locke, Victor, N.Y. for the manufacture of triple-petticoat, high-voltage, pin type insulators. Both these companies lost a patent infringement suit to R. Thomas & Sons Co. (East Liverpool) regarding these pin type insulators and had to make an accounting for damages. The subsequent history of Electrical Porcelain & Manufacturing Company is not known to me.

EMPIRE CHINA WORKS

Located at 156 Greene St., Greenpoint, Brooklyn, N.Y. Watts stated that he had been told many times that this company produced the first electrical porcelain insulators in the U.S. by molding in plaster molds, and that these were for Waldo Bryant Electric Co., Bridgeport, Conn. This would have been prior to 1879.

No other information.

EVEREADY PORCELAIN COMPANY

Sales name for split knobs manufactured by Davidson Porcelain Co., East Liverpool, Ohio (q.v.).

FEDERAL PORCELAIN COMPANY, The

The plant is located at 225 N. Patterson St., Carey, Ohio (43316). Established in 1917 for the manufacture of electrical and special porcelain products. When the plant was constructed, the company stated that it was the most modern plant of its kind in the world. The plant covered considerable area and originally used six beehive kilns. The officers of the company were originally E. C. Edwards (Pres.), C.G. Spencer (Treas.), and R. G. Spencer (General Manager).

The company commenced production in 1918, and they had one of the largest lines of standard porcelain items of any company. Additionally, they manufactured various styles of pin type insulators, all by the dry process. Their tradename "FEDCO" was used on standard porcelain and also on at least one style of telephone pin type.

Federal Porcelain was one of several companies which merged in 1927 to form Porcelain Products, Inc. (q.v.). Ultimately this was the one plant in which P.P. Inc. combined all their dry press porcelain insulator manufacturing. (See picture of the old Federal plant on the next page.)

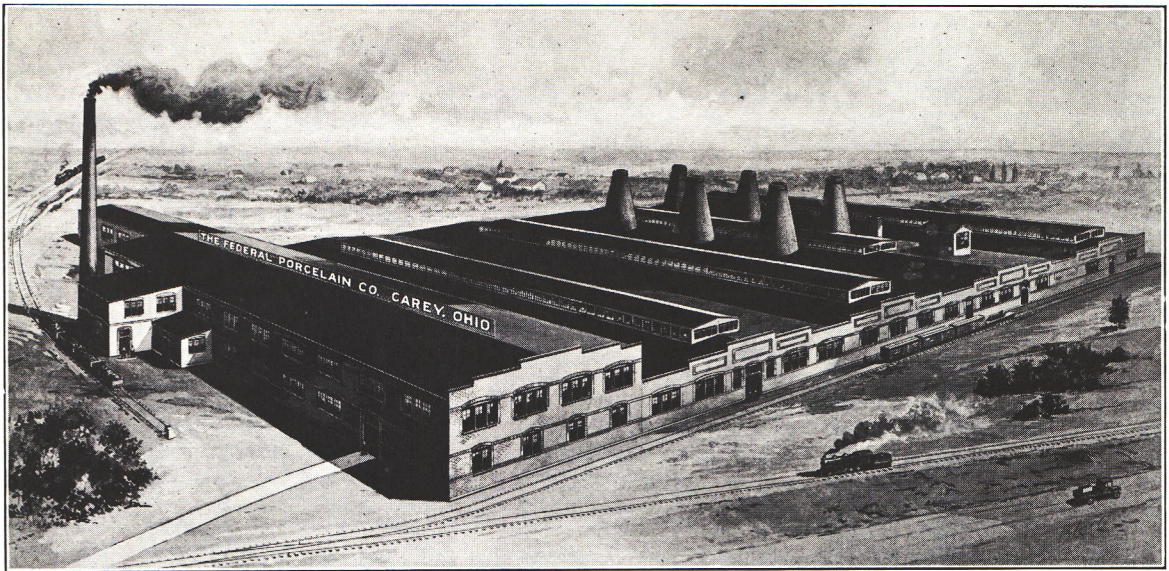

FINDLAY ELECTRIC PORCELAIN COMPANY

The plant was located at the end of Bell Ave. in Findlay, Ohio, and its history is as follows:

1899	Bell Pottery Co.	Vitreous tableware
1906	U. S. Electric Porcelain Co.	Electrical porcelain
1910	Findlay Electric Porcelain Co.	" "
1927	Porcelain Products, Inc.	" "
1927+	(moved to Carey, Ohio plant)	
1955	Property sold	

The plant was built in 1899 by Bell Pottery Co., and it was refitted for electrical porcelain manufacture when U.S. Electric Porcelain (q.v.) bought it in 1906.

The officers of Findlay Electric Porcelain Co. were J.E. Bicknell (President), F. E. Owen (Secretary). The main product line was initially standard porcelain, plus a small amount of specialty porcelain, all made by dry process. Later a complete line of pin type insulators was manufactured, all by wet process.

The company was one of several companies that merged in 1927 to form Porcelain Products, Inc. (q.v.). Shortly thereafter, the manufacturing equipment was moved to the Carey, Ohio plant of P.P. Inc., and offices of P.P. Inc. dry press manufacture were maintained in Findlay until 1955.

The dumpage from this plant is spectacularly large and intact at the edge of the property. Virtually every size, shape and form of standard electrical porcelain is available by the ton in this dump. The marking most common on the standard porcelain is "F", but the following markings were also used: "F E P Co", "F. E. P. Co." and "FINDLAY". The markings used on the wet process pin types are various forms of the word "FINDLAY" and various styles of "Diamond-F", both with or without catalog numbers.

Findlay used the trademark "BUCKEYE" on split knobs, and specimens are found with that marking. This trademark was registered (#114,735), January 2, 1917, with "used since March 1914" noted.

FREEMAN PORCELAIN COMPANY

Data from several sources are confusing or in conflict. One source states the company was in operation at Chambers Street and Freeman Alley, Trenton, N. J. prior to 1930, and that they formerly operated an electric shop at that site. A 1921 directory lists E. H. Freeman Electric Co., but at 803 E. State Ave. which is not a factory location. (Note this address is that of business offices used by factory representatives, some of whom were for the various porcelain companies of the area.)

E. H. Freeman Co. used a Circle-F trademark on wiring devices, and note under Cook Pottery Company that a Circle F Manufacturing Company had a porcelain manufacturing division. It is not possible with these piecemeal facts from my files to determine which companies were sales outlets only and which actually manufactured, or where the manufactories were located in Trenton. Some of these addresses in Trenton are in neighborhoods which were not overly stimulative to my research efforts!

GENERAL ELECTRIC COMPANY

General Electric has one of the earliest connections with the electrical porcelain industry. Bergman Electric Co., 17th St. and Avenue A, New York made receptacles and cutouts (both of wood) under Edison patents and began investigating porcelain to replace the wood for insulation. In 1887 Bergman, together with John J. Kraus (manufacturer of artistic pottery at E. 18th St., New York), started experimenting with dry press porcelain. The product was put into production in 1888, with Bergman Electric Co. taking the entire output for their own manufacture. Bergman was subsequently absorbed by Edison Machine Company which later became General Electric Company.

Within a very short space of time, all use of wooden insulators for wiring was abandoned because of their extreme fire hazard, and the demand for porcelain insulators was instant and great. General Electric quickly built a porcelain insulator plant at their Schenectady, N.Y. location, and this plant was in operation in 1892. The plant was located adjacent to the eastern division of the Schenectady works, between Kruesi Avenue and the New York Central tracks. It was a two-story building covering a space of about 14,000 square feet.

The company made all types of standard porcelain insulators and was probably for many years the largest manufacturer of terminal insulators of all types (switches, receptacles, cutouts, rosettes, etc.). The most common marking used by G. E. on all dry press insulators was "G. E. Co.", and nearly all specialty insulators also carried their catalog number.

By 1895 (or slightly earlier), General Electric was also making at the Schenectady plant large, double-petticoat insulators rated at 25,000 volts. These were dry press insulators and used on the Folsom-Sacramento power transmission installation (California). Similar dry press pin type insulators were installed in Utah and proved so unsatisfactory that G.E. gave Imperial Porcelain Works (Trenton) an order to replace them with the wet process insulators made by Imperial.

General Electric also leased porcelain insulator manufacturing space in East Liverpool, Ohio and possibly elsewhere (see G. F. Brunt Porcelain Company). The company evidently abandoned the manufacture of dry process

pin type insulators within a short time, but they entered the wet process insulator field in a big way near the end of World War I when they bought an interest in Locke Insulator Manufacturing Co. (Victor, N.Y.). They also constructed a very large insulator plant in Baltimore, completed in 1922, and subsequently became sole owners of Locke in 1934.

GENERAL PORCELAIN COMPANY

This company was established in 1913 as the result of a merger of the following porcelain manufacturers (founding dates noted):

- 1895 G. F. Brunt Porcelain Co., East Liverpool, Ohio
- 1903 East Liverpool Electric Porcelain Co., E. Liverpool, Ohio
- 1897 Ohio Porcelain Co., East Liverpool, Ohio
- 1899 Anderson Porcelain Co., East Liverpool, Ohio
- 1911 Sun Porcelain Co., Trenton, N.J.
- 19?? Diamond Porcelain Co., Trenton, N.J.
- 19?? Virginia Pottery Co., New Lexington, Ohio

Various sources give varying dates and circumstances of the merger, but the most reliable source indicates that the first four companies named above merged to form Sun Porcelain Co. in 1911, and then Sun Porcelain merged in 1913 with the last two listed to form General Porcelain. What information is known about each of the companies involved in the two mergers is given under the names of the individual companies.

General Porcelain constructed a large insulator plant at Parkersburg, W. Va. and was headquartered there. All the other plants were dismantled and the equipment sent to Parkersburg, the various properties being sold off within a short while after they were abandoned. The one exception was the G. F. Brunt plant which was still used by General Porcelain until the early 1920's before being abandoned.

The company continued the manufacture of standard and special electrical porcelain at Parkersburg, but also commenced the manufacture of wet process insulators, including a line of pin types and other line type insulators. Their first general catalog of pin types was dated 1923.

Their marking on electrical porcelain was "G. P. Co.". They used a tradename marking of "GEE PEE" on split knobs.

The company continued operations as General Porcelain Co. until 1927 when they merged with five other companies to form Porcelain Products, Inc. (q.v.).

GLOBE PORCELAIN COMPANY

This company was located at 127 Mulberry St., Trenton, N.J. It was founded in 1913, officers being Joseph Steinert (Pres.), Morris Steinert (Sec'y-Treas). Although it's thought that all porcelain manufacture had ceased about 1965, the property was bought by Renselaar Corp. on 7-19-71. The buildings are used for warehousing.

There is a possible connection between the owners, and the products manufactured, with a former company. Globe Pottery Co. was established

in East Liverpool, Ohio in 1881 for the manufacture of Rockingham and Yellow, and commenced the manufacture of Semiporcelain in 1888, the plant being located on River Road east of Colonial Pottery. For a brief period (1903-1905) the name was East Liverpool Pottery Co.

This Globe Pottery Co. in East Liverpool was bought by T.A. McNicol Pottery Co. in 1913. It is possible the Globe owners could have been the Steinerts, and who subsequently founded Globe Porcelain Co. in Trenton. The large building in Trenton has a very large painted wall which reads "GLOBE BATH ROOM FIXTURES", and this could have been the early product of the company before the manufacture of electrical porcelain, or the final product line after electrical porcelain manufacture ceased.

The company manufactured standard porcelain insulators, and markings consisted of variations of "GLOBE". The date spans of the manufacture of electrical porcelain by the company are unknown to me.

GREENWOOD POTTERY COMPANY

Various sources give different dates, locations and details, but the following account is reasonably compatible with each source. Addresses given below are all in Trenton, N.J.

Originally established in Trenton, N.J. by the Stephans & Tams Co. (Charles Brearley, James P. Stephans, James Tams). They converted to a pottery a carriage factory formerly erected by a Mr. Stutphin. Various sources give this plant location as: (1) East Canal St., (2) Greenwood Ave. alongside the canal, (3) on East Canal St., (4) on East Canal St., south from East State St., (5) on east bank of canal and on north side of Assanpink Creek.

An 1891 source stated that operations were begun under a special charter in 1861, becoming an incorporated company in 1863. Also that, "There are practically two concerns -- Greenwood Pottery Co. and the Greenwood China Co., the later incorporated ... and manufacturing the same items as the pottery company and erected on account of room". Greenwood Pottery had 12 kilns, and Greenwood China Co. had 7 kilns. These occupied two acres and had 300-325 workmen (all as of 1891). They manufactured china plus electrical and telephone and telegraph supplies.

An 1882 source stated that, "On July 1, 1868, a stock company was formed, and the works were improved and doubled in capacity under the management of the Greenwood Pottery Co.", and this agrees with the 1891 source quoted above. This was incorporation of Greenwood China Co.

On October 17, 1882 a large fire consumed part of the Greenwood Pottery Co. on East Canal St. -- the frame portion originally being the old carriage factory.

In 1923 Watts quoted C. C. Treischel, "In America, as far as the writer can learn, the first electrical porcelain was made by the dust or dry process, and the credit for this accomplishment goes to Greenwood Pottery Co. of Trenton, N.J. This was in 1879. The articles were two-piece insulators, probably knobs, and were given two firings, one biscuit and one glost."

Although we do have these several glimpses of this early electrical porcelain manufacture, it is unfortunate that we know essentially nothing of the nature of the insulator manufacture -- what was made, when manufacture of electrical porcelain ceased etc. The entire area involving the original plants has long since completely changed in character.

HALL CHINA COMPANY

This company is located in East Liverpool, Ohio at Harvey & Elizabeth Sts. They currently manufacture fine porcelain cooking and serving ware. The main plant in the Klondyke area (eastern East Liverpool) was established in 1930. Prior to that time, Hall China Co. had bought and operated at least four other small potteries in East Liverpool from 1905 to 1927 -- moving everything to the Klondyke plant in 1930.

All these other plants under Hall had been making either porcelain or semiporcelain, or were converted to that by Hall. It is not unreasonable to think that some standard or specialty electrical porcelain might have been manufactured by Hall at one of the old plants in East Liverpool or even at some time after 1930 in the new Klondyke plant. This possibility is brought up inasmuch as specimens of telephone knobs exist which are prominently embossed "HALL", and also because there are at least some electrical porcelain remnants around the Klondyke plant. The later isn't very meaningful, since pottery company dumpage is generally used for fill in new construction throughout the East Liverpool district.

The four East Liverpool potteries bought and operated by Hall prior to 1930 are listed below with start date and name of most important owner preceding Hall ownership. Date bought by Hall is in parenthesis.

- (1905) 1894 E. Liverpool Potteries Co., SE corner Walnut & 4th Sts.
- (1919) 1893 Goodwin Pottery Co., NE corner Broadway & 6th Sts.
- (1926) 1894 Wm. Brunt Pottery Co., NE corner Walnut & 3rd Sts.
- (1927) 1902 D. E. McNicol Pottery Co., East side of Starkey St.

HARTFORD FAIENCE COMPANY

The plant is located at 271 Hamilton St., Hartford, Conn. (06106). Established in 1894 (Clarence E. Whitney, Pres.), but originating in the 1860's as the Atwood Company and later Atwood Faience Company.

The manufacture of electrical porcelain commenced in about 1902 with dry process manufacture continuing until 1947. The company nearly always was a manufacturer of specialty electrical porcelain ware but did make a line of standard porcelain. Markings used on dry press insulators were "H. F." and "H. F. Co."

In the early 1920's Hartford also started placing emphasis on wet process porcelain insulators and by 1925 was making a small line of pin type and other line insulators by wet process. Graybar Electric Company was a Hartford distributor starting in 1927. The marking on these line insulators was a stylistic "H" accompanied by the catalog number.

ILLINOIS ELECTRIC PORCELAIN COMPANY

This plant is located at 510 N. Pearl St., Macomb, Illinois (61455). Its history is as follows:

1910	Illinois Electric Porcelain Co.	Electrical porcelain
1951	(T. M. Evans becomes owner)	" "
1953	Line Material Co., Division of McGraw Electric Co.	" "
1957	Line Material Co., Division of McGraw-Edison Co.	" "
1967	Mc-Graw Edison Co., Power Systems Div.	" "
1977	(In operation)	

The company was founded by C. W. Kettron in 1910 and operated by the Kettron family until sold to T. M. Evans in 1951.

The product was initially only dry process electrical porcelain consisting of knobs, tubes, cleats and specialty items. A line of dry press pin type insulators was also made until the 1920's. Illinois was one of the larger manufacturers of dry press porcelain insulators for many years and used Joslyn Mfg. & Supply Co. as their primary distributor.

The product was always advertised and sold under "The Macomb Line", and the original trademark (unregistered) on insulators was "MACOMB". The trademark was changed to Triangle-M on January 1, 1915, and this was registered (#107,575) December 14, 1915.

A trademark "BULL-DOG" was used on split knobs commencing July 1918, and two forms of this trademark were later registered -- #172,397 on Aug. 8, 1923, and #198,982 on June 2, 1925.

Illinois commenced the manufacture of wet process line insulators in 1915 and became one of the larger manufacturers of high voltage insulators as their operation grew. This is the main product now, and dry press manufacture now consists only of small pieces incidental to the making of the wet process insulators.

IMPERIAL PORCELAIN WORKS

This plant was located on the northwest corner of Mulberry St. and Klagg Ave. (457 Mulberry St.) in Trenton, N.J. The large masonry building and an associated wooden structure still remain on the property.

The company was founded in July 1891 by Frederick A. Duggan. He had formerly been with Trenton China Co. which had become bankrupt and gone into receivership in June 1891. Benjamin B. Dinsmore, also formerly with Trenton China Co., went with Mr. Duggan in 1891 and later acquired a part interest in Imperial. Duggan had purchased the plant of Dowd Stilt Works and converted it to the manufacture of electrical porcelain.

The Imperial plant was totally destroyed by fire February 3, 1897 with a loss of \$70,000, but it was immediately rebuilt. The company went defunct in the 1930's, being used during World War II as a parachute factory, and now as a warehousing point of paper products for the Winans-Reliance Corporation. Some remnant porcelain insulators still remain on the property as evidence of the manufacture.

The company was founded to manufacture dry press standard porcelain, and this was always the main product. Duggan achieved some reknown for

having developed a line of one-wire cleats which later were a starting point for standardized cleats in the industry. He also had early patents on wiring insulators of several forms. Aside from the embossed "DUGGAN" on the various cleats, the only other marking readily attributable to Imperial was an "I", always recess-embossed.

Imperial also entered the wet-process, high-voltage insulator market in 1897 and made insulators for many of the important early lines. They initially manufactured insulators for Fred M. Locke (Victor, N.Y.) but later sold on their own account, primarily using C.S. Knowles (Boston) as their distributor. Probably because of not being competitive in the very rapidly growing high voltage insulator market, Imperial ceased manufacturing high voltage insulators within ten years. Their high voltage insulators are prominently marked with the company name and address.

KENNELWORTH TILE COMPANY

Located in Newell, W. Va. and listed by one source as a manufacturer of standard shapes of electrical porcelain insulators. No other information.

KIRCHBERGER (,M.) & COMPANY, INC.

Located at 250 Humphrey St., Englewood, N.J. (07631). Established in 1890 and operated by the Kirchberger family. They originally manufactured lava insulators and bushings but are now listed as manufacturers of electrical porcelain insulators. They used a trademark "LAVAROCK".

No other information.

KNOX PORCELAIN CORPORATION

Located in Knoxville, Tennessee (Box 4107, 37921). Founded in 1923 and subsequently purchased in 1927 by a group of Knoxville businessmen, O. A. Dorsett becoming president and general manager and remaining president until his death in 1967.

The company has always been a comparatively large manufacturer of dry press electrical porcelain, both standard porcelain and specialties, and this manufacture continues to the present. The marking used by Knox on standard porcelain is "KNOX".

Commencing in about 1936, the company has manufactured wet process pin type and specialty high voltage insulators. The marking used on this ware has always been "KNOX".

METSCH REFRACTORIES, INC.

This plant was located at the northwest corner of 3rd and Harrison Streets, Newell, W. Va., and its history is as follows:

1910	Novelty Clay Forming Co.	Clay novelties
1919	Boch-Metsch Porcelain Co.	Elec. & Heating porcelain
1922	Metsch Refractories Co.	" " " "
1973	(In operation)	

John W. Boch, Sr. had in 1907 established an electrical porcelain plant on 6th Street in Newell, W. Va. While carrying on that operation, he became associated with Cassius M. Metsch and established in 1919 the Boch-Metsch Porcelain Company for the manufacture of "standard porcelain" (split knobs, etc.) and specialty insulators (bushings, etc.).

Boch withdrew from this company in 1922, and the name was changed to Metsch Refractories, Inc. (now Box 193, Chester, W. Va. 26034). Current product line is dry press electrical porcelain and electrical refractory porcelain used in the electrical apparatus, controls, appliance and heating industries.

MILLIGAN PORCELAIN COMPANY, T. V.

Please see listing under "Adamant Porcelain Company".

MOGADORE INSULATOR COMPANY

See "Akron Smoking Pipe Company". In April 1920, the company changed its name to Mogadore Insulator Company to make it more representative of the character of the business.

NATIONAL CERAMIC COMPANY

Located at 500 Southland St., Trenton, N.J. (08602). As of approximately 1953, this was the new name for National Porcelain Co. (q.v.).

NATIONAL ELECTRIC PORCELAIN COMPANY

This plant was located in Carey, Ohio between Crawford Street and the G. & O. Railroad tracks. Incorporated in July 1916 and in partial operation by March 1911. The officers were W.L. Bish (Pres), W.R. Kurtz (V.P.), J.D. Ewing (Secretary) and H.F. Graves (Treasurer).

The company manufactured a complete line of standard porcelain insulators. Some of the markings used were "N", "NAT." and "NCO". They also used a trademark of "READY" on assembled split knobs.

This was one of five companies which merged in 1927 to form Porcelain Products, Inc. (q.v.). Within several years after the merger, this National Porcelain Co. plant was closed and, together with equipment from three other dry press facilities involved, all dry press insulator manufacturing was carried on at the Federal Porcelain Co. plant in Carey.

NATIONAL PORCELAIN COMPANY (Trenton)

Located at 500 Southland St., Trenton, N.J. Established in 1906 for the manufacture of electrical porcelain insulators. Directories listed products as mine insulators, telephone and telegraph insulators, porcelain sockets and insulators.

The company stock was sold on receivers sale in 1953 for \$186,120 to the former plant manager, Joseph A. Schermerhorn. Presumably this is the date of the name change to National Ceramic Co. (q.v.).

No information as to possible markings used by this company on their standard or specialty porcelain insulators.

NEW HAVEN PORCELAIN COMPANY

There were two electrical porcelain companies by this name -- both involving the same plant in New Haven, W. Va. For details, please refer to the listing for "Superior Porcelain Company".

NEW JERSEY PORCELAIN COMPANY

Located at Garson & Plumb Sts., Trenton, N. J. (08638). Established in 1920. Manufactured dry process insulators and specialties, and also bathroom accessories under the brand name "Monarch".

No other information.

OHIO PORCELAIN COMPANY

The plant was located on 7th St. opposite West End Pottery in East Liverpool, Ohio. There are two references for the location of West End Pottery (take your pick): (1) corner of 8th and Mill, and (2) corner of Lisbon & Mill.

Established in 1897. The officers included William J. Curry (Pres), J. Clemont McQuilken (Secretary) and William A. Anderson (Treasurer).

The company manufactured a line of standard porcelain insulators and at least one known style of pin type insulator. Their marking on insulators was "O. P. CO."

This was one of a number of companies involved in the 1911 and 1913 mergers to form General Porcelain Company (q.v.). The plant was shortly thereafter closed by G. P. Co. The above officers, being then idled, bought another pottery in East Liverpool and formed American Porcelain Company (q.v.).

PASS & SEYMOUR, INC.

Founded in 1890 and located in Solvay (Syracuse, N.Y.). Mr. James Pass was associated with the Onondaga Pottery Co. of Syracuse, and it was he who in 1888 developed the hard, strong, non-absorbent china which came to be known as "Syracuse China". Mr. Seymour was associated with the Thompson-Houston Company of New Britain, Conn. and was sent to Syracuse as superintendent of the local lighting plant. Seymour sought out Pass to provide the porcelain know-how to make better insulators for power distribution, and the company was founded with this purpose in mind.

From the outset, wiring and specialty porcelain insulators were manufactured. Pin type insulators were made for several years by the casting process, but these were soon discontinued and all energies devoted to making other insulator types and miscellaneous associated equipment. The marking used throughout the company history has generally been "P & S".

The company is currently one of the larger manufacturers of wiring devices of all types.

PEACH PORCELAIN COMPANY

Please see the listing under "Adamant Porcelain Company".

PERU ELECTRIC MANUFACTURING COMPANY

Located in Peru, Indiana, the company was organized in 1892 as a stock company with a capitalization of \$100,000. It was originally known as the Peru Electric Works. In 1893 the porcelain building was destroyed by fire, and the company bought the Dow plant across the railroad tracks (the present location), expanded it and refitted it for the manufacture of electrical porcelain. The company was defunct by 1920.

In 1925 the idle plant was bought by the Square-D Company (q.v.).

Peru Electric Mfg. Co. manufactured a large and varied line of electrical porcelain insulators and specialty porcelain for electrical terminal fixtures. They also made a line of high voltage pin type insulators, presumably by dry process, and this is confirmed by a trade journal photo of their exhibit at an 1898 trade fair.

The original Peru plant dumpage has been almost completely eradicated by later construction and grading, but some specimens were in evidence that bore a "PERU" marking. No pin types have ever been located which can be definitely attributed to the company.

PORCELAIN PRODUCTS COMPANY

Originating January 1, 1959 with the reorganization of the porcelain insulator operations of the A. B. Chance Company. Sold in the 1960's to the Clarken Company, St. Louis, Mo. and is an operating division of that company. The porcelain plant is at 225 N. Patterson St., Carey, Ohio.

The plant operates substantially as before, but they also now manufacture wet process electrical insulators and nonelectrical specialties. For additional details, please refer to "Porcelain Products, Inc."

PORCELAIN PRODUCTS, INC.

The company came into being in July 1927 with the merging of six porcelain insulator companies, all as illustrated by the chart below.

All of these companies were engaged in dry press insulator manufacture. Only Findlay and General Porcelain Company had also been making wet process insulators, including lines of pin type insulators.

Findlay was chosen as the headquarters location, although the plant at Findlay was ultimately closed as a manufactory. Within several years after the merger, four of the plants had been closed and the equipment moved to the two surviving plants. Wet process manufacture was confined to the Parkersburg plant, and dry process manufacture was confined to the Federal Porcelain Co. plant in Carey, Ohio.

The company's general offices were moved to Parkersburg in 1955. The offices for the Carey dry press plant remained at Findlay but were moved to the Carey property on September 24, 1957.

Through purchase of stock, Porcelain Products, Inc. became a wholly owned subsidiary of the A. B. Chance Co. in May of 1956. On January 1, 1959 the porcelain division was divided into two parts. The Parkersburg wet process plant became an operating division of the A, B. Chance Co., and the Carey, Ohio dry process plant became Porcelain Products Company, a wholly owned subsidiary of the A. B. Chance Co. In the 1960's, this later company was sold to the Clarcken Company of St. Louis, Mo.

From the outset, the company used the markings "P. P. INC." and "P P" on both dry press and wet process insulators. However, they did continue the use of former tradenames such as "FINDLAY" until die markings and catalog cuts could be changed over. They used the tradename "ALLIGATOR" on assembled split knobs.

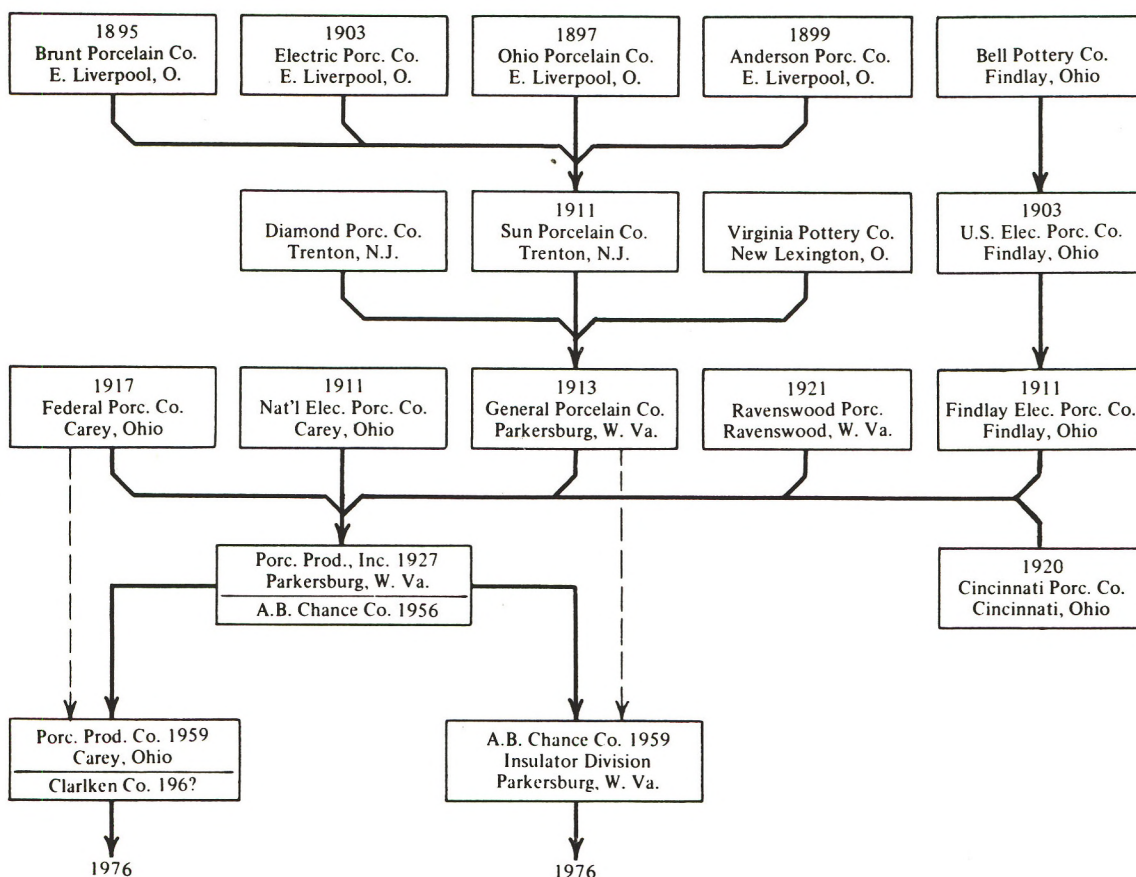

RAVENSWOOD PORCELAIN COMPANY

This company, located on the banks of the Ohio River in Ravenswood, W. Virginia was founded in 1921. The original officers were G. E. Mason, (Pres), Mike E. Ginther (Secy), Charles Trumbull (Gen Mgr), and Bill Hall (Treasurer).

The company made only dry press porcelain insulators and sold a line of standard porcelain knobs, cleats, etc. The marking used on these items was "R. P. Co.". They also made contract items such as Sackett mine insulators, rack spools, etc.

This company was one of six electrical porcelain manufacturers which merged in 1927 to form Porcelain Products, Inc. (q.v.). It was shut down almost immediately, thereby ending production of electrical porcelain in Ravenswood.

The property was bought in 1929 by T. V. Milligan but remained idle until 1937. Milligan had owned and operated T. V. Milligan Porcelain Co. in East Liverpool, Ohio from 1915 until selling it to Peach in 1929.

Gus Trenle, former owner of Trenle Porcelain Co. in East Liverpool (1915-1937), bought the Ravenswood plant in partnership with H. W. Blake in 1937. The company name was Trenle-Blake China Company, and it made a line of hotel china until closing in 1965. It was bought and operated by Harold Compston, first employed by the plant in 1921, and operated substantially without change until closing again in 1969. The plant is now idle and rapidly falling into a state of disrepair.

SOUTHERN ELECTRICAL PORCELAIN COMPANY, INC.

Established in 1920 at Erwin, Tennessee. Officers were J. S. Thorp (Pres.), J. W. Owen (V.P. & Gen Mgr), C. W. Davis (Sec'y-Treas.)

Manufactured by dry press standard porcelain insulators, specialty porcelain and pin type insulators. No other information.

SOUTHERN PORCELAIN, INC.

Located at 504 Clay St., Marietta, Georgia 30060. Founded in April 1947 and incorporated in August 1955. Its purpose was the manufacture of thermal shock resistance ceramics.

The company entered the electrical porcelain field in 1967 and has manufactured low-voltage dry press insulators, wet process bushings and, what is now their main line, slip-cast, high-strength porcelain. They make open-end guy strain insulators, switchgear and replacements for obsolete equipment.

No information as to what forms of dry press insulators have been made or what markings were used on them.

SPECIALTY PORCELAIN WORKS

For details, please refer to listing under "Boch, John".

SQUARE-D COMPANY

In 1925 the Square-D Company bought the porcelain insulator plant in Peru, Indiana formerly owned by Peru Electric Mfg. Co. (q.v.). This was operated from 1925 to 1951 as the Molded Insulator Division of Square-D Company, and they made all forms of porcelain insulators by dry process. The plant is still owned by Square-D Company, but no porcelain is manufactured there now.

Although Square-D Co. did make some proprietary items, including two styles of pin type insulators, they were essentially a job shop making specialty porcelain insulators on contract for other companies. Hubbard Company was one of their favored customers. There is considerable plant dumpage remaining on the perimeter of the property as evidence of the 1925-1951 porcelain manufacture. The variety of specialty items is very large. The marking used on proprietary items and as a marking key on the contract items was their registered trademark, a Square-D.

STAR PORCELAIN COMPANY

The company first occupied a plant on Seward Ave, Trenton, N.J., but they later moved to the current location on Muirhead Ave. near Dewey in Trenton. The company once maintained an office in Frenchtown, N.J.

Founded July 22, 1899 by Herbert Sinclair, Thomas MacKenzie and Dr. Charles P. Britton. Sinclair had the knowledge of the manufacturing process. Star also has another division in Trenton (estab. 1915), Bay Ridge Specialty Shop (q.v.).

From its founding date to the present, Star has manufactured electrical porcelain insulators and specialties. It added a line of high voltage insulators in 1901, but this manufacture was dropped in 1907.

The marking used on porcelain insulators was generally just a five-pointed star, registered #518,499 on 12-6-49, "used since 1899".

A marking "STAR" was occasionally used, and it was registered #518,500 on 12-6-49, "used since 1899".

They used a marking "IDEAL" on split knobs, but no trademark registration could be located for this marking.

STEWARD (D. M.) MANUFACTURING COMPANY

Located in Chatanooga, Tennessee (Box 510, 37401). Established in 1876, trade journal references indicate Steward was making lava electric insulators (knobs illustrated) as early as 1891. The tradename for their lava insulators was "LAVITE". The company is still in business, but no other information is on file.

SUN PORCELAIN COMPANY

Was located in Trenton, N.J. on Oakland Ave. & Pennsylvania Railroad. Was one of the companies involved in the 1911-1913 mergers to form General Porcelain Company (q.v.). See also the family tree shown under the section on "Porcelain Products, Inc.". No other information.

SUPERIOR PORCELAIN COMPANY

This plant is located aside the railroad tracks on the Ohio River in New Haven, W. Va., and its history is as follows:

1919	West Virginia Porcelain Co.	Electrical porcelain
1925	New Haven Porcelain Co. (#1)	" "
1929	Superior Porcelain Co.	" "
1964	New Haven Porcelain Co. (#2)	" "

West Virginia Porcelain Co. was founded and the plant built in the summer of 1919. The first production of insulators was in 1920. Split knobs are known with the marking "W. VA. P. CO."

The company underwent increasing financial difficulties and was put up for auction in 1925. It was bought by a group of 10 or 12 local people and incorporated as New Haven Porcelain Co. (#1 above). No insulator markings are known which can be attributed to this 1925-1929 operation.

This company was then bought by George O. Anderson, and the name was changed to Superior Porcelain Co. He had been with General Porcelain Co. (Parkersburg) since his former company Anderson Porcelain Co. was absorbed by the G. P. Co. combine in 1911. After the G. P. Co. merger into Porcelain Products, Inc. in 1929, Anderson became disenchanted with that company, so he quit and bought the plant in New Haven.

Superior manufactured a complete line of standard porcelain insulators plus many specialty and contract items. They used markings "SUPERIOR" and "S. P. Co." on their proprietary insulators.

The company office was always located in Parkersburg, W. Va. where Mr. Anderson lived. The plant was operated by G. O. Anderson and his son, Smith Anderson, who preceded him in death. The plant was sold by the Anderson estate to the present owners, once again a group of people in New Haven, and the name was changed once again to New Haven Porcelain Co. (#2 above). The company still sells under the "SUPERIOR" line, and items still carry the same markings.

An oil-fueled space heater got out of control in December 1970, and the entire plant burned to the ground. It was rebuilt (this time with a metal building), and the first kiln firings after rebuilding were in January 1973.

TECHNICAL CERAMICS & LAVA CORP.

Located on Ray Place (Box 676), Fairfield, N.J. (07006). Although the company currently is a manufacturer of a broad line of precision ceramic products including insulators for the electronics industry, it has manufactured a variety of electrical porcelain insulators and specialties. No other information.

THOMAS (,R.) & SONS COMPANY

The original plant was on the north side of West 7th Street in East Liverpool, Ohio, and its history was as follows:

1873	American Knob Works	Clay door knobs
1884	R. Thomas & Sons	Electrical porcelain
1892	R. Thomas & Sons Co., Inc.	" "
1927	Moved to newer Lisbon plant	" "

(see following chart)

The second plant owned by the company was located in Lisbon, Ohio on the south side of Washington St. at the railroad crossing. Its history:

1900	Thomas China Company	Semiporcelain
1905	R. Thomas & Sons Co., Inc.	Electrical porcelain
1957	H. K. Porter Co.	High-voltage insulators
1963	Operations suspended	
1973	Dismantled & refurbished for aluminum extrusion plant	

Richard Thomas and his father, John Thomas, came to this country from Staffordshire, England and in 1873 opened a one-kiln plant in East Liverpool for the manufacture of clay door knobs. The name of the company was American Knob Works.

The company was reorganized and expanded in 1884 for the manufacture of electrical porcelain insulators, and the name was changed to R. Thomas & Sons. The first kiln of this ware was marketed in 1884 to U.S. Lighting Co. of Chicago at the time of organization of the National Electric Lighting Association. In 1885 Thomas began production of low voltage porcelain insulators in a large way. By 1887 Thomas was marketing insulators to Brush Electric Assn, Detroit Electric Works, Pittsburgh Electric Co., Central Electric (Chicago), Keystone Light & Power Co., Westinghouse Electric and others. Thomas was the main supplier of the period.

Specimens of knobs exist which bear the marking "R. T. & SONS", and these could have come from the early 1884-1892 manufacture.

The company incorporated in 1892 under the name R. Thomas & Sons Co. after very rapid expansion which culminated in Thomas having bought the entire porcelain plant of Westinghouse Electric Co. At this time, Thomas had over 200 employees and was claimed to be the most extensive works in the country making porcelain insulators as their specialty.

The Lisbon plant was owned by Al G. Mason, a member of the Thomas "family", and it was absorbed in R. Thomas & Sons Co. in 1905 for the manufacture of porcelain insulators. Thomas had entered the high-voltage insulator business in 1897 and rapidly outgrew the old facilities in East Liverpool. During this period, A. G. Mason was general manager of the Lisbon plant, and J. H. Holmes manager of the East Liverpool plant.

The Lisbon plant was converted and enlarged to a modern insulator plant in 1918, and the East Liverpool plant was closed in 1927. Richard Thomas' four sons were George W., Lawrence L., Atwood W. and Charles R. By the 1920's much of the company management was under the two sons of George W. Thomas -- Richard G. and L. M. Thomas.

Markings on Thomas dry press insulators from 1892 to 1957 include "R. T. & S. Co.", "THOMAS" and "T".

The early East Liverpool plant site has been eradicated by highway construction. Some dumpage remained in 1973 on the periphery of the later Thomas plant at Lisbon.

TRENLE PORCELAIN COMPANY, The

This plant was located in East Liverpool, Ohio on the north side of Railroad St. east of Boyce Street. Its history was as follows:

1894	East End Pottery Co.	White granite
1903	East Liverpool Potteries Co.	Semiporcelain
1905	East End Pottery Co.	"
1910	East End China Co.	"
1915	Trenle China Co.	"
1917	The Trenle Porcelain Co.	Porc. & Elec. porcelain
1937	Moved to Ravenswood, W. Va.	

Founded by S. Turnbull, J. Doekin, E.J. Owen and Gus A. Trenle. The company was refitted in 1917 for the manufacture of electrical porcelain. The plant ceased operation in 1937 when Trenle bought the Ravenswood (W. Va.) Porcelain Co. plant (q.v.), therein establishing the Trenle-Blake China Company.

Trenle used a marking "TRENLE" on standard porcelain insulators, and specialty insulators have been found at the old plant site with a marking "T.T.P. Co." (The Trenle Porcelain Co.).

Wiring cleats have also been found at this same plant location which bear the marking "E. E. P. Co.", and it is possible these were manufactured by Trenle's predecessor, East End Pottery Co.

TRENTON CHINA COMPANY

This plant was located in Trenton, N.J. on 3rd Street below the (old) state prison. Its history (in part) is as follows:

1869	Trenton Terra-Cotta Co.	Terra-cotta
1880	Trenton China Co.	China hotelware
1888	Trenton China Co.	China & Electrical porcelain
1891	(Operations suspended)	
1892	Maddock & Sons	??

The 1869 company was organized by three Quaker businessmen -- George Comfort, Alex Bell and Johnathan Stewart.

Trenton China Company was then organized in November 1880 with James Moore as president. The main product was vitrified tableware for hotels, but electrical porcelain was also manufactured commencing 1888. There is no information on the type of porcelain insulators manufactured.

The company was in the hands of a receiver in 1891 and was purchased by Thomas Maddock & Sons on May 11, 1892. F.A. Duggan and B.B. Dinsmore left Trenton China after the 1891 failing and founded Imperial Porcelain Works (q.v.) for the manufacture of electrical porcelain.

TRENTON PORCELAIN COMPANY

It is unclear as to whether this was only a sales company or if they did have a porcelain manufacturing plant at some location. Data from my

files are given below.

The company gave the semblance in directories of being a large porcelain manufacturer. They were listed under categories: solid and split knobs, cleats, tubes, porcelain bushings, mine insulators, rack insulators, strains, telephone & telegraph pin types, etc.

They used as a business address 803 E State Ave., Trenton, N.J., and gave New Brunswick, N.J. and Trenton, N.J. as locations of their factories. The State Ave. location is in a business district and no factory could have been located there. I have never inspected a possible factory site in New Brunswick. These locations, including the 803 E. State Ave. address exactly fit the locations given for E. H. Freeman Co. (q.v.).

In 1921 the officers of Trenton Porcelain Co. were E. H. Freeman (Pres), George E. Maguire (Sec-Treas) and P.T. Bradley (Sales Mgr). This agrees exactly with the officers of E. H. Freeman Co. also.

Trenton Porcelain used tradenames "JIFFY", "BUCKEYE" and "FINDLAY" for split knobs, and these were actually tradenames of knobs made by Findlay Electric Porcelain Co., Findlay, Ohio. The BUCKEYE was registered by Findlay. Knobs with the JIFFY marking also appear in plant dumpage of General Porcelain Co. at Parkersburg. All of this points in the direction that Trenton Porcelain contracted others to make their ware.

Knobs are commonly found with a marking "T. P. Co.", some of which are in combination on the same knob with the "JIFFY" marking, and these can be found in dumpage at Findlay, Ohio.

Obviously a few key bits of information could turn up which would fill in the story on Trenton Porcelain Co. and E. H. Freeman Co.

UNION ELECTRICAL PORCELAIN COMPANY

This company is located at 31 Muirhead Ave., Trenton, N.J. (08605). Its history is as follows:

1865	Union Electric Co.	
1924	Union Electrical Porcelain Works	Electrical porcelain
1959	Union Electrical Porcelain Co.	" "
1977	(In operation)	

The company established in 1865 by the Mackenzie family and operated by the family for many years. In 1920 the officers still were mostly of the Mackenzie family: J. D. Mackenzie (Pres.), Duncan Mackenzie (V.P.), T. Mackenzie (Treas.), W. I. Peacock (Sec'y and General Manager).

The original company had always been located at Hamilton and Clark Streets in Trenton, but it moved to the Muirhead location in 1924 and was incorporated as Union Electrical Porcelain Works. In 1959, the company was reincorporated as Union Electrical Porcelain Company without changes otherwise. The current president, Frederick P. Van Orden, said that the current location was formerly that of the Greenwood Pottery Co. plant, but this appears in conflict with other sources on Greenwood.

The company for many years manufactured a great variety of specialty porcelain insulators for other companies, but it has its own proprietary line of porcelain sign insulators.

Markings that have been used by the company include "U", "UNION" and Shield-U. Note that "U" was also used by Universal Clay Products as a code marking on contract porcelain insulators.

UNION PORCELAIN WORKS

Operating before the Civil War in the manufacture of heavy tableware and hardware trimmings. Advertisements in 1888 trade journals gave their address as 300 Eckford St., Greenpoint (Brooklyn), New York, and indicated they were making "Hard porcelain insulators, large and small, for electric work, telephone, telegraph."

Watts states that Union Porcelain Works started making porcelain insulators shortly after Empire China Works (q.v.), and Empire started before 1879. Needless to say, any such insulators would have been for signal use, since the light bulb hadn't even been invented by that time.

Porcelain knobs have been reported which have an underglaze marking consisting of "U. P. W." over an eagle's head with arrows in its beak, and it is not unthinkable that this could be a proper trademark for a china company of this period. Reference books on potteries making tableware might confirm this trademark.

UNION POTTERY COMPANY

One source states that Union Pottery Company was incorporated March 30, 1869 with a capitol stock of \$25,000. Located in Trenton, N.J.

An 1883 source states that The Union Pottery Company is (1883) the name of a new association formed to operate the works of the defunct New Jersey Pottery Company (in Trenton).

No other information. (Note: A company in East Liverpool, Ohio operated under the name Union Pottery Company from 1891 to 1904.)

UNITED STATES ELECTRIC PORCELAIN COMPANY

(Refer also to "Findlay Electric Porcelain Co.") This company was located in Findlay, Ohio. It was founded in 1906, utilizing by refitting the plant of Bell Pottery Company. The company manufactured standard electrical porcelain until 1910 when it became Findlay Electric Porcelain Company.

There are numerous specimens of the early manufacture on the edges of the mountains of dumpage at the plant site. The most common marking used was a Monogram-US which appears at first glance to be a \$ sign. The other markings noted were "U S E P Co" and "U.S.P.Co."

UNIVERSAL CLAY PRODUCTS COMPANY

Located at 1528 - 1st St. (Box 1631), Sandusky, Ohio (44870). The company manufactured dry process porcelain insulators in standard and special shapes, both glazed and unglazed. They also make wet process porcelain insulators, notably rack spools, wireholders, etc.

The company has used the marking "UNIVERSAL" and also uses a factory code marking "U" on contract insulators and possibly some proprietary insulators. No other information.

VIRGINIA POTTERY COMPANY

Located in New Lexington, Ohio, this was one of the companies which merged in 1913 to form General Porcelain Company (q.v.).

The most notable insulator company located in New Lexington was New Lexington High Voltage Porcelain Company (1902-1918), and they made only wet-process, high-voltage insulators.

One historical compilation of Ohio potteries includes information on New Lexington High Voltage but failed to mention Virginia Pottery Co. in the same town, and I could find no trace of the latter when I visited the town and vicinity. Nevertheless, one insulator collector reported that he had once seen an insulator catalog by Virginia Pottery Company.

No other information.

WASHINGTON PORCELAIN COMPANY

Located on Southeast Willow St., Washington, N.J. (07882). Since 1917 the company has manufactured electrical porcelain for the parent company, Arrow Hart, Inc., Hartford, Conn. They also manufacture electrical porcelain to customer specifications.

One source listed a company operating as Washington Porcelain Company on Muirhead Ave., Trenton, N.J. prior to 1930.

No other information.

WEST VIRGINIA PORCELAIN COMPANY

The founding company of the electrical porcelain plant in New Haven, W. Va. For details, please refer to "Superior Porcelain Company".

WHEELING TILE COMPANY

Located in Wheeling, W. Va. I estimate the company was founded 1918 to 1919. Officers were Samuel O. Laughlin (Pres), C. R. Hubbard (V.P.), J. B. Youngson (Sec-Treas). (Note: There is a probable family connection of Samuel Laughlin with the Homer Laughlin China Co., Newell, W. Va.)

The Wheeling Tile Co. manufactured standard porcelain insulators and possibly specialty porcelain insulators. They had a patent July 29, 1919 on nail knobs, and these were also marked "W. T. Co.".

No other information.

WISCONSIN PORCELAIN COMPANY

Located at 120 Lincoln St., Sun Prairie, Wisconsin (53590). Founded in 1919 by Ludwig A. Stohl and still operated as a family business. The production manager is Ludwig's son, L. J. Stohl.

The company has always manufactured an extensive line of electrical porcelain insulators and specialties, all by dry press. In recent years the company has manufactured concurrently as many as 6,000 different items with a production rate of several million pieces daily. Besides the regular electrical porcelain items, they manufacture by dry press all types of items from refractory porcelain, steatite and other types of ceramic bodies.

Markings used on insulators have included "WIS-P", "WIS-P-C.", and "WISP", the latter mostly on electric fence insulators. A marking "W P" is also known on knobs and is probably that of Wisconsin Porcelain Co.

AKRON HIGH-POTENTIAL PORCELAIN COMPANY

A company (name unknown) was formed about 1900 for the manufacture of general ceramic products. The plant was located in Barberton, Ohio, now a suburb of Akron. Several years later, this company was reorganized to another group as Akron High-Potential Porcelain Company. "Standard porcelain" was manufactured by dry process at first, but the company became involved in wet process manufacture shortly thereafter -- probably between 1903 and 1905. Ohio Brass Company took Akron H-P's output of the high voltage insulators and owned the company outright by 1910

Evidently Akron H-P discontinued manufacturing the dry press insulators almost immediately after they started making high voltage items by wet process. Wiring cleats are known (but are rare) with a marking of "H. P. CO." which is attributed to Akron H-P, since their catalog cuts were labeled in an identical manner.

Chapter 5

PORCELAIN INSULATOR MARKINGS

The following tabulation of markings will allow a great many specimens to be attributed to specific companies. The great majority of these markings are taken from actual insulator specimens, but some are trade-names advertised by the company in connection with the indicated class of insulator and which could be expected to turn up on specimens. Some that are listed as "unattributed" appear to match certain company names listed in old directories, but engaging in initial-matching has always led to a frustratingly high degree of errors in the past. Attributions are firmed only with good basis -- specimens found in plant dumpage, in the original cartons, shown in company literature, accompanied by patent or cataloging numbers belonging to the company, etc.

The class of insulators shown for each company indicates either the major porcelain items made by the company or the particular types of insulators made by the company on which the marking was used. The following notes will explain the classification terminology used:

Standard porcelain -- generally the complete range of standard items such as cleats, knobs, tubes, split knobs, etc. Some large porcelain companies made a very extensive line. Others made only the high-volume items such as split knobs and wiring cleats. Many wiring insulators (especially #334 cleats and split knobs) bear jobber trademarks, and these could have been made by any contracted porcelain company.

Wiring devices -- various insulating devices not connected with routing of the wires in a structure. These include ceiling rosettes, pendent switches, wall switches, sockets, plugs, current taps, etc.

Specialty items -- all types of special purpose porcelain items made by the company as proprietary items or on contract for others. Relating to electrical porcelain, this could be anything from sparkplug cores to bases for tap-changing switches on a transformer. Most porcelain companies made anything for which they could contract, and nonelectrical specialty items are abundant in their plant dumpage.

Radio antenna insulators -- as sold separately, or in antenna installation kits with wire, these are guy strains, nail knobs, small screweyes and lightning arrestors. Many have colored glazes, and most markings on them are those of radio companies or wire manufacturers.

Poleline hardware -- generally insulators used on pole lines, but also including insulators to services -- rack spools, wireholdres, etc.



Akron Insulator & Marble Co., Akron, Ohio, standard porc.

Appleton Electric Co, Chicago, end outlet bushings

Anderson Mfg Co, Albert & J M, Boston, plugs & receptacles

A C unattributed, clamp insulators

A C F Co. unattributed, telephone cleats & knobs

ACME Crescent Elec'c Co, Mtn Grove, Mo, rosettes, sockets, etc.

ACME Reliable Elec'c Co, Chicago, switches, connectors, cutouts

ADAPTI Adapti Co, The, Cleveland, conduit items

 unattributed (Boston, Mass), guy strains

A. E. Co. Automatic Elec'c Co, Chicago, tel insulators & specialties

A. I. & M. CO. Akron Insulator & Marble Co, Akron, Oh, standard porcelain

AJAX Ajax Elec'c Co, Jersey City, NJ, ground'g & wir'g devices

AJAX Ajax Elec'c Specialty Co, St Louis, Mo, radio & wir'g dev.

ALADDIN Pass & Seymour, Inc, Syracuse, NY, plug-socket switch

ALLIGATOR Porcelain Products, Inc, Findlay, Ohio, split knobs

ALPHA unattributed, radio antenna insulators

AMERICAN American Porcelain Co, E Liverpool, Oh, standard porcelain

AMERICAN ELEC CO INC (of Chicago), telephone equipment & supplies

AMERICAN SUNDRIES CO. (of Brooklyn), electrical specialties

ANYLITE Anylite Electric Co, Ft Wayne, Ind, sockets

 American Porcelain Co, E Liverpool, Oh, standard porcelain

A.P.C.L. unattributed, special knobs

A. P. Co. Anderson Porcelain Co, E Liverpool, Oh, standard porcelain

APPLETON ELECTRIC CO. (of Chicago), end outlet bushings

ARGUS Foote, Pierson & Co, Inc, New York Cy, tel & tel arrestors

ARROTYPE Arrow Electric Co, Hartford, Conn, plug fuses

ARROW Arrow Conductor & Mfg Co, Chicago, tel & tel arrestors

ARROW Arrow Electric Co, Hartford, Conn, wiring devices

A.S.P.Co. Akron Smoking Pipe Co, Mogadore, Ohio, standard porcelain

B unattributed, standard porcelain

 unattributed, specialties

BABY Solar Electric Co, Chicago, sign receptacles

B & B Betts & Betts Corp, New York, NY, bushings, specialties

B D unattributed, standard porcelain

B & D Buffinton & Dow patent (licensed), cleats, split knobs

BEAVER Beaver Machine & Tool Co, Newark, NJ, wiring devices



B. E. Co. Bryant Elec'c Co, Bridgeport, wiring devices, specialties

BENBOW Parker & Son, J H, Parkersburg, W Va, mine insulators





BENCO Benjamin Electric Mfg Co, Chicago, sockets





BENDHICK Fairmount Electric & Mfg Co, Phila, Pa, conduit fittings



BENDIX	Bendix Radio Corp, radio antenna insulators
BENJAMIN	Benjamin Elec'c & Mfg Co, Chicago, wiring devices, splcls
BESCO	unattributed, radio antenna insulators
BEST	Best Electric Corp, New York, NY, wiring devices
BINKLEY	Binkley Mfg Co, Warrenton, Md, wireholders
BIRNBACH	Birnbach Radio Co, New York, NY, radio antenna insulators
BOSS	Elec'l Specialty Mfg Co, Prov, RI, cleats, outlet bushings
BRACH	Brach Mfg Co, L S, Newark, NJ, insulators & specialties
BRASCO	unattributed, secondary rack spools
BRUNT	Brunt Porcelain Co, G F, E Liverpool, Ohio, standard porc.
BRYANT	Bryant Elec'c Co, Bridgeport, wiring devices, specialties
BSCO	Edison Storage Battery Co, Orange, NJ, wet batteries
B & T	Brunt & Thompson, E Liverpool, Ohio, standard porcelain
BUGKEYE	Findlay Electric Porc Co, E Liverpool, Ohio, split knobs
BULL DOG	Illinois Electric Porcelain Co, Macomb, Ill, split knobs
BULL DOG	Mutual Electric & Machine Co, Detroit, switches, cutouts
BUNNELL	Bunnell & Co, J H, New York, NY, lgtnng arrestors, bushings
C	unattributed, split knobs
Ⓒ	unattributed, split knobs
Ⓒ	unattributed, standard porcelain
Ⓒ	Cook Pottery Co, Trenton, standard porcelain, specialties
CAMPBELL	Steel City Electric Co, Pittsburgh, Pa, receptacles
CAPLETS	Phelps, James C, Springfield, Mass, end outlet bushings
CAREY - O.	Carey Ohio Porcelain Co, Carey, Oh, std porc & specialties
CAREY / OHIO	ditto
C. C. E.	unattributed, standard porcelain
C E CO.	Central Electric Co, Chicago, standard porc & specialties
Gem Co	Connecticut Elec'c Mfg Co, Bridgeport, Ct, wiring devices
CENCO	unattributed, standard porcelain
C.F.W.& M.CO.	Chicago Fuse Mfg Co, Chicago, fuse cutout bases
C.G.R.	Robin, Charles G, New York, NY, end outlet bushings
C - H	Cutler-Hammer Mfg Co, Milwaukee, wiring devices, speclties
CHAPMAN	Bryant Electric Co, Bridgeport, Conn, receptacles
CHAPMAN	Minnesota Electric Co, Mimmeapolis, tel & tel arrestors
CHASECO	Chase Electric Co, Chicago, wiring systems
Ⓔ	Crouse-Hinds Co, Syracuse, NY, end outlet bushings
CHICAGO	Chicago Steel Foundry Co, Chicago, secondary rack spools

C Colonial Insulator Co, Akron, Oh, std porc & specialties
 C. I. Co. ditto
 CINCH Brunt Porcelain Co, G F, E Liverpool, Ohio, split knobs
 COLONIAL Parker & Son, J H, Parkersburg, W Va, split knobs
 COLORADO Flint Electric & Mfg Co, Denver, mine signaling systems
 CONDULET Crouse-Hinds Co, Syracuse, NY, end outlet bushings
 CONDULETTO ditto, wiring devices
 CONLON Conneaut Metal Works Co, The, Conneaut, Oh, wiring devices
 CONNECTICUT Conn Tel & Electric Co, Meriden, Conn, lightning arrestors
 COOK Cook Electric Co, Chicago, tel & tel lightning arrestors
 FRANK B. COOK CO. / CHICAGO ditto above
 COOK / TRENTON Cook Pottery Co, Trenton, NJ, standard porc & Specialties
 COOKE WILSON E. S. CO. unattributed (on U-98 mine insulators)
 C.O.P. Carey Ohio Porcelain Co, Carey, Oh, stand porc & speclties
 CORWIGO Cornish Wire Co, Inc, New York, NY, radio antenna insuls.
 COX Cox arrestor Co, Eaton, Oh, tel & tel lightning arrestors
 C. P. Co. Cook Pottery Co, Trenton, NJ, standard porc & specialties
 CRL Centralab, Inc, Milwaukee, radio antenna insulators
 CROSS COUNTRY unattributed, electric fence insulators
 CROUSE-HINDS Crouse-Hinds Co, Syracuse, NY, end outlet bushings
 C.S.I. Co. Colonial Sign & Insulator Co, Akron, stand porc, speclties
 C.S.& I.Co. ditto
 C. S. K. Knowles Co, C S, Boston, Mass, wiring devices
 ditto, switches, rosettes
 C. S. KNOWLES ditto, wiring devices
 CTS Chicago Tel Supply Co, Cgicago, tel insulators & speclties
 CUTTER Cutter, Scott C, Oswego, Ill, tree insulators
 CUTTER Westinghouse Elec'c & Mfg Co, E Ptsbg, arc light equipment
 C W & A C Consolidated Wire & Assoc'd Corp, Chicago, radio ant insul







D Square-D Co, Detroit, pin type insulators & specialties
 D-2 (etc.) (standard sizes forestry insulators: D-1, D-2, D-3, etc.)
 DAVIDSON Davidson Porcelain Co, E Liverpool, Oh, standard porcelain
 DETROIT Parker & Son, J H, Parkersburg, W Va, split knobs
 DIAMOND EXPANSION BOLT CO. (of New York), bridle ring insulators
 DOUBLEX Parker & Son, J H, Parkersburg, W Va, strain insulators
 D. P. Co. Davidson Porcelain Co, E Liverpool, Oh, standard porcelain
 D & S Davidson & Stevenson Porc Co, E Liverpool, standard porc.



D & S P Co.	Davidson & Stevenson Porc Co, E Liverpool, standard porc.
DUGGAN	Imperial Porcelain Works, Trenton, NJ, cleats
DYKE	Parker & Son, J H, Parkersburg, W Va, porcelain knobs
E	East Liverpool Elec'l Porc Co, E Liverpool, stand. porc.
	Standard Specialty Mfg Co, Cleveland, end outlet bushings
	Arrow Electric Co, Hartford, Conn, wiring devices
EAGLE	Eagle Elec'c Mfg Co, L I City, NY, radio antenna insuls.
EDISON	Edison Storage Battery Co, Orange, NJ, wet batteries
E E E	Elec'l Engrs Equipmt Co, Chicago, hi-tension elec'l equip.
E. ENG. CO.	unattributed, standard porcelain
E. E. P. Co.	East End Pottery Co, E Liverpool, Ohio, standard porcelain
E E & S Co.	Elec'c Engineering & Supply Co, Syracuse, NY, specialties
EFFICIENCY	Efficiency Elec'c Co, The, E Liverpool, porcelain cleats
E.G.B. Co.	Bernard Co, E G, Troy, NY, early cleats (adjustable)
EICO	Electro Importing Co, New York, NY, radio antenna insuls.
ELECTROLET	Killark Electric Mfg Co, St Louis, Mo, end outlet bushings
EL RE CO	Electric Railway Equipment Co, Cincinnati, special knobs
E. M.	Electrical Mfg Co, Battle Creek, Mich, wireholders
E. M. Co.	ditto
EMICO	unattributed, end outlet bushings
EMILY	(special class of screweye insulators, all manufacturers)
E.M.W. Co.	unattributed, wireholders
ENDO	Gillette-Vibber Co, New London, Conn, end outlet bushings
ENDOULETS	Fralick & Co, S R, Chicago, end outlet bushings
ENSIGN	unattributed, large spools
ENTWISTLE	unattributed, specialties
E. P. Co.	Electrical Porcelain Co, E Liverpool, Oh, standard porc.
E. R. E.	Electric Railway Equipment Co, Cincinnati, mine insulators
ERIE	Erie Elec'l Equipmt Co, Johnstown, Pa, cleats, specialties
E. S. S. Co.	Electric Service Supplies Co, Phila, Pa, mine insulators
EUREKA	unattributed, split knobs
EVER READY	Davidson Porcelain Co, E Liverpool, Ohio, split knobs
F	Findlay Electric Porcelain Co, Findlay, Oh, standard porc.
	Freeman Electric Co, E H, Trenton, NJ, wiring devices
	Findlay Elec'c Porcelain Co, Findlay, Oh, porcelain insuls
FAIRMOUNT	Fairmount Electric & Mfg Co, Phila, Pa, wiring devices
FARM MASTER	(Wards or Sears), electric fence insulators

F. C. M.	Mesa Co, Fernando C, Irvington, NJ, wiring devices
	unattributed, strain insulators
F. E. Co.	Federal Elec'c Co, Chicago, porc bushings, wiring devices
FEDCO	Federal Porcelain Co, Carey, Oh, standard porc & speclties
FEDERAL	Federal Electric Co, Chicago, wiring devices
F E P Co	Findlay Elec'c Porc Co, Findlay, Oh, stand porc, speclties
FINDLAY	ditto, standard porcelain
FIVE HUNDRED	Freeman Electric Co, E H, Trenton, NJ, wiring devices
FLERON	Fleron & Sons, M M, Trenton, NJ, radio antenna insulators
FLETCHER	Fletcher Mfg Co, J R, Dayton, Ohio, clamp insulators
FLUTO	Pass & Seymour, Inc, Syracuse, NY, sockets
FORT WAYNE ELECTRIC WORKS	(of Ft Wayne, Ind), primary fuse cutouts
	unattributed, dry process secondary rack spools
FRANKLIN	Elec'l Development & Machine Co, Phila, hi-tension spclts
FUSEGUARD	Electric Fusegard Co, Inc, Newark, NJ, fuse cutouts
G	unattributed, standard porcelain & pin types
	Grabler Mfg Co, The, Cleveland, Ohio, end outlet bushings
GAMEWELL	Gamewell Co, Newton Upper Falls, Mass, signaling systems
GATE INSTALATOR	Accessories Mfg Co, Chicago, electric fence insulators
G. C. F. CO.	unattributed, standard porcelain
G. E. Co.	General Elec'c Co, Schenectady, NY, stand porc & specialty
GEE PEE	General Porcelain Co, Parkersburg, W Va, split knobs
GEE - VEE	Gillette-Vibber Co, New London, Conn, end outlet bushings
GLOBE	Globe Porcelain Co, Trenton, NJ, standard porcelain
GOLIATH	Pass & Seymour, Inc, Syracuse, NY, sockets
GOODRICH/CHICAGO	unattributed, specialties
GORDON	Gordon Electric Mfg Co, Waterville, Ct, sws, receipts, etc.
G P Co.	General Porcelain Co, Parkersburg, W Va, std porc, speclty
GRIP-IT	Parker & Son, J H, Parkersburg, W Va, split knobs
GUARDIAN	Muter Co, The, Chicago, radio antenna insulators
G & W	G & W Electric Spclty Co, Chicago, poleline hardware items
	Hart Mfg Co, Hartford, Conn, switches
	Hubbard & Co, Pittsburgh, Pa, poleline hardware
HALL	unattributed, special 2-groove knob
HAMILTON	unattributed, specialties
HAMMOND	Hammond Cleat & Insulating Co, Boston, special cleats
HARDWICK HINDLE, INC.	(of Newark, NJ), specialties

HARRIS	(John R Harris patent #1,302,158), split knobs
HECO	Heineman Electric Co, Phila, Pa, wiring devices
HEMCO	Hemco Electric Mfg Co, New York, NY, wiring devices
H.F.	Hartford Faience Co, Hartford, Conn, standard porcelain
H. F. Co.	ditto, specialties
H & H	Hart & Hegeman Mfg Co, Hartford, Conn, sws, wiring devices
HI-TEN	Hubbard & Co, Pittsburgh, Pa, poleline hardware
H & M	Elm City Engineering Co, New Haven, Conn, specialties
HOLD FAST	Adamant Porcelain Co, E Liverpool, Ohio, split knobs
HOLMES	High Tension Elec'l Spclty Co, Newton, Mass, tree insuls.
HOPEWELL	Hopewell Insulation & Mfg Co, Hopewell, Va, wiring devices
H. P. CO.	Akron High-Potential Porc Co, Barberton, Oh, stand. porc.
H & S	Hickey & Schneider, Inc, Elizabeth, NJ, lo & hi-volt equip
H.T.P. Co.	Paiste Co, H T, Phila, Pa, wiring devices
 	ditto
HUBBARD	Hubbard & Co, Pittsburgh, Pa, poleline hardware
HUBBELL	Hubbell, Inc, Harvey, Bridgeport, Conn, wiring devices
HUDSON	unattributed, standard porcelain cleats
(I) or (1)	Imperial Porcelain Works, Trenton, NJ, special insulators
IDEAL	Star Porcelain Co, Trenton, NJ, split knobs
ILLINOIS	Illinois Elec'c Porc Co, Macomb, Ill, stand porc, speclty
ISOLANTITE	Isolantite Mfg Co, Stirling, NJ, radio antenna insulators
I T	Electric Appliance Co, Chicago, specialties
<u>J</u>	unattributed, wireholders
J.C.P.	Phelps, James C., Springfield, Mass, end outlet bushings
JEFFERSON	Jefferson Electric Mfg Co, Chicago, specialties
J.H.P. & S.	Parker & Son, J H, Parkersburg, W Va, specialties
JIFFY	Trenton Porcelain Co, Trenton, NJ, split knobs
J.I.P. INC.	Paulding, Inc. J I, New Bedford, Mass, wiring devices
JOHNSON	Johnson Co, E F, Waseca, Minn, radio antenna insulators
JOSLYN	Joslyn Mfg & Supply Co, Chicago, poleline hardware
JUNIOR	Bryant Electric Co, Bridgeport, Conn, cleat rosettes
JUPITER	Cutter Co, George, South Bend, Ind, arc light porc insuls
K	unattributed, wireholders
(K)	unattributed, standard porcelain & specialties

KANT-BREAK unattributed, specialties
 K-C King-Craymer Electric Mfg Co, S Norwalk, Ct, sws, cutouts
 K-E Kirkman Engrg Corp, New York, NY, cutouts, cleat-recepts.
 KEARNEY Kearney Corp, James R, St Louis, Mo, wireholders
 KEYLESS unattributed, keyless ceiling switches
 KEYSTONE Electric Service Supplies Co, Phila, Pa, poleline hardware
 KILLARK Killark Electric Mfg Co, St Louis, Mo, conduit items
 KIRKMAN Kirkman Engineering Corp, New York, NY, wiring devices
 K K K Killock Co, David, New York, NY, porcelain bushings
 KLINGEL Klingel, E L, St Paul, Minn, special knobs
 KNAPP Knapp Foundry Co, Inc, Akron, Ohio, secondary rack spools
 KNOWLES Knowles Co, C S, Boston, Mass, wiring devices
 KNOX Knox Porcelain Corp, Knoxville, Tenn, stand porc & specilty
 KOLUX Kollarth Bros, Schenectady, NY, sign insulators
 KONDU-BOX unattributed, end outlet bushings
 K.P. Bryant Electric Co, Bridgeport, Conn, rosettes
 KRETZER BRAND St Louis Lightning Rod Co, St Louis, Mo, lgtng rod access.
 Kuhlman Electric Co, Bay City, Mich, primary fuse cutouts
 KWIKON Fralick & Co, S R, Chicago, wiring devices

 L or  unattributed, wireholders
 unattributed, wireholders
 unattributed, rack, clamp, wireholder insulators
 LEVITON Leviton Mfg Co, Brooklyn, standard porcelain & specialties
 LF or  L F Mfg Co (Louis Fort), Jersey City, NJ, clamp insulators
 LINGO unattributed, specialties
 LITTLE GEM Pass & Seymour, Inc, Syracuse, NY, rosettes
 L.M. Line Material Co, Milwaukee, Wis, poleline hardware
 or  ditto
 LOCK SHELL Hubbell, Inc, Harvey, Bridgeport, Conn, switches, sockets

 M or  Illinois Elec'c Porc Co, Macomb, Ill, stand porc & specilty
 unattributed, wireholders
 MAGOMB Illinois Elec'c Porc Co, Macomb, Ill, standard porcelain
 MANDIGO Manufacturer's Distributing Co, New York, sign receptacles
 MANHATTAN Manhattan Elec'l Supply Co, Inc, New York, wiring devices
 M. B. Co. unattributed, standard porcelain & specialties
 M. E. Co. unattributed, specialties

MEMCO	Maxwell Engrg & Mfg Co, New York, NY, tel & tel arrestors
MESCO	Manhattan Elec'l Supply Co, New York, wiring devices
METEOR	unattributed, switches
M I CO	Mogadore Insulator Co, Mogadore, Oh, stand porc & specilty
MILHAM	American Sign Co, Kalamazoo, Mich, sign insulators
MONCUR	unattributed, specialties
MONOWATT	unattributed, standard porcelain & specialties
MULLER	Parker & Son, J H, Parkersburg, W Va, strain insulators
MULTI	Multi Electrical Mfg Co, Chicago, conduit items
MULTIPO	Paiste Co, H T, Phila, Pa, sockets
MURDOCK	Parker & Son, J H, Parkersburg, W Va, misc. insulators
N	Nat'l Electric Porcelain Co, Carey, Oh, standard porcelain
NAILIN	unattributed, split knobs
NAILIT	Parker & Son, J H, Parkersburg, W Va, split knobs
NAT	Nat'l Electric Porcelain Co, Carey, Oh, standard porcelain
NAT'L	National Electric Products Co, Pittsburgh, Pa, wireholders
NATIONAL	National Metal Molding Co, Pittsburgh, Pa, conduit items
NCO	Nat'l Electric Porcelain Co, Carey, Oh, standard porcelain
N.E.E. Co.	New England Electric Co, Littleton, Colo, special knobs
N.E.T.& T.CO.	New England Tel & Tel Co, telephone knobs and cleats
N. W. Co.	unattributed, special knobs
O. B. Co.	Ohio Brass Co, Mansfield, Ohio, mine insulators
OHIO	Frankel Light Co, New York, NY, end outlet bushings
OLIVER	Oliver Elec'l Mfg Co, Battle Creek, Mi, poleline hardware
O. P. Co.	Ohio Porcelain Co, E Liverpool, pin types & std porcelain
P	Peru Electric Mfg Co, Peru, Ind, standard porcelain
P or (P)	Porcelain Products, Inc, Findlay, Ohio, standard porcelain
(P)	Pittsburg High Voltage Insulator Co, Derry, Pa, strains
◇ P ◇	unattributed, radio antenna insulators
P A Co.	Pettingell-Andrews Co, Boston, Mass, standard porcelain
PAISTE	Paiste Co, H T, Phila, Pa, wiring devices
PARAGON	Paragon Electric Co, Chicago, misc. porcelain insulators
PASSMOUR	Pass & Seymour, Inc, Syracuse, NY, sockets
PATTERSON	Stanley & Patterson, New York, NY, specialties
PAULDING	Paulding, Inc, J I, New Bedford, Mass, wiring devices
P. B. MFG. Co.	unattributed, end outlet bushings

PEARL unattributed, wireholders

PEIRGE Hubbard & Co, Pittsburgh, Pa, poleline hardware

PEMCO Phila Electrical & Mfg Co, Phila, Pa, poleline hardware

PERU Peru Electric Mfg Co, Peru, Ind, standard porcelain

PHILCO Philco Radio Corp, radio antenna insulators

POWERLET Multi Electrical Mfg Co, Chicago, porcelain bushings

PP Porcelain Products Co, Carey, Oh, stand porc & specialties

P.P. Porcelain Products, Inc, Findlay, Ohio, standard porcelain

P.P. INC. ditto

PINC.P. ditto

PRIME unattributed, electric fence insulators

PRINGLE Pringle Elec'l Mfg Co, Phila, Pa, stand porc & specialties

PRO-TECTO unattributed, radio antenna lightning arrester

P & S Pass & Seymour, Inc, Syracuse, NY, stand porc & specialty

P S W unattributed, split knobs

P. T. - G. CO. unattributed, specialties

QUAD General Electric Co, Schenectady, NY, receptacles

R Ravenswood Porcelain Co, Ravenswood, W Va, stand. porcelain

RACO Raco Elec'c Products Div, All Steel Co, Chicago, specialty

RALCO Central Electric Co, Chicago, wiring devices

READY National Electric Porcelain Co, Carey, Ohio, split knobs

R. E. CO. Reliable Elec'c Co, Chicago, standard porcelain & speclty

RECO. ditto, specialties

RED DEVIL Smith & Hemenway Co, Inc, Irvington, NJ, wiring devices

RELIABLE Reliable Electric Co, Chicago, standard porcelain

R-H & CO. Reyburn-Hunter & Co, Pittsburgh, lightning rod equipment

ROCK unattributed, standard porcelain

RODALE Rodale Mfg Co, Emmaus, Pa, radio antenna insuls, speclties

ROYAL Royal Electric Mfg Co, Chicago, standard porcelain

R. P. Co. Ravenswood Porcelain Co, Ravenswood, W Va, standard porc.

R R Radio Receptor Co, New York, NY, radio antenna insulators

R. R. S. Co. Railroad Supply Co, Chicago, railway signaling systems

R.T. & SONS R Thomas & Sons, E Liverpool (pre-1892 unicorp), std porc

R T & S CO ditto (after 1892 incorporation), standard porcelain

RUBY Bryant Electric Co, Bridgeport, Conn, sign receptacles

RVA Great Lakes Radio Supplies Co, Inc, Elmhurst, Ill, radio

S unattributed, telephone knobs, wireholders, etc.

SACKETT "Sackett Patent" mine insulators, various manufacturers

S & C Schweitzer & Conrad, Inc, Chicago, cutouts, wiring devices

S.C.P. Co. unattributed, split knobs

SCREWIT Parker & Son, J H, Parkersburg, W Va, split knobs

SEALET Butte Electric & Mfg Co, San Francisco, Cal, end outlets

Sears/USA unattributed, electric fence insulators

SEBCO Star Expansion Bolt Co, New York, NY, misc. insulators



SECURITY Freeman Electric Co, E H, Trenton, NJ, wiring devices

SENSORY Heineman Electric Co, Phila, Pa, wiring devices, screweyes

SEYLER Seyler Mfg Co, rack spools, wireholders, etc.

SHAWMUT Chase-Shawmut Co, Newburyport, Mass, cutout bases

S - H Co. Snyder-Hunt Co, Belle Plaine, Iowa, special knobs

 or  Stewart-Howland Co, Boston, standard porcelain

SHURLOK Pass & Seymour, Inc, Syracuse, NY, sockets & receptacles

SISSELL Sissell Co, Lloyd D, Los Angeles, Cal, rack spools

SKY-ROCKET Chance Co, A B, Centralia, Mo, tel & tel lgtng arrestors

S.M.T. Co. So Mass Tel Co, telephone knobs

SNAP-CATCH General Elec'c Co, Schenectady, porc sockets & receptacles

SNAPIT unattributed, switches

SOLDERALL Solderall Co, The, Newark, NJ, radio antenna insulators

S.P. Superior Porcelain Co, Parkersburg, W V, stand porc & spl

S. P. Co. ditto

SPERO unattributed (Cleveland, Ohio), wireholders

S P W Specialty Porcelain Works, E Liverpool, standard porcelain

 ditto

S. P. W'KS ditto, specialties

STANDARD Standard Electrical Mfg Co, Cleveland, end outlet bushings

STANDARD ELEC. MFG. CO. (of Chicago, Ill), switches

STAR Star Porcelain Co, Trenton, NJ, standard porcelain & splty

ST LOUIS St Louis Malleable Casting Co, Mo, secondary rack spools

SUPERIOR Superior Porcelain Co, Parkersburg, W V, stand porc & spl

SURGE Babson Bros Co, Chicago, electric fence insulators

S W P unattributed, standard porcelain

S.Y. unattributed, special knobs









 Trumbull Electric Mfg Co, Plainville, Conn, switches

T or (T) Thomas & Sons Co, R, E Liverpool, Ohio, standard porcelain
TAPLET unattributed, end outlet bushings
TAPON Jordan Bros, New York, NY, porcelain crossovers
T & B Thomas & Betts Co, The, New York, NY, wiring devices
TEGGO Trenton Elec'c & Conduit Co, NJ, sign & wiring insulators
TEMCO Trumbull Electric Mfg Co, Plainville, Conn, switches
TERMILET Freeman Electric Co, E H, Trenton, NJ, end outlet bushings
THOMAS Thomas & Sons Co, R, E Liverpool, Ohio, standard porcelain
T. P. Trenton Porcelain Co, Trenton, NJ, stand porc & specialty
T. P. Co. ditto
TRENLE Trenle Porcelain Co, The, E Liverpool, Ohio, standard porc
TRIANGLE Bunnell & Co, J H, New York, NY, lightning arrestors
T.T.P.Co. Trenle Porcelain Co, The, E Liverpool, std porc & specilty
TULIP Pass & Seymour, Inc, Syracuse, NY, sign receptacles
TWIN TOWERS Accessories Mfg Co, K.C., Mo, elec'c fence lgtng arrestors

U or (U) Union Elec'l Porcelain Co, Trenton, NJ, sign specialties
U or (U) Universal Clay Products Co, Sandusky, Oh, std porc & spcl
UNILETS Appleton Electric Co, Chicago, end outlet bushings
UNION Bunnell & Co, J H, New York, NY, tel & tel arrestors
UNION Chicago Fuse Mfg Co, Chicago, primary cutouts & cut. bases
UNION Union Elec'l Porcelain Co, Trenton NJ, sign & specialties
UNIVERSAL Universal Clay Products Co, Sandusky, Oh, std porc & spcl
U.P.W. Union Porcelain Works, Brooklyn, NY, early knobs
U S or \$ U S Electric Porcelain Co, Findlay, Oh, standard porcelain
U S E P Co ditto
U.S.P.Co. ditto
U. S. CO. Utility Services Co, Allentown, Pa, rack spools, wirehldrs

VAC-M Michigan Elec'c Specialty Co, Muskeegon, tel & tel arrest.
V.V. V V Fittings Co, Phila, Pa, end outlet bushings

W. D. INC. unattributed, specialties
WEBER Weber Electric Co, Schenectady, NY, porcelain sockets
WEDGE Cook Pottery Co, Trenton, NJ, split knobs
W E S Co. unattributed, standard porcelain
W.E.S.& Co. unattributed, standard porcelain
WESTERN ELECTRIC (of New York, NY), standard porcelain cleats
WHITE White Electrical Supply Co, T G, St Louis, Mo, guy strains

WIRT	Wirt Co, Phila, Pa, special knobs
WIS-P	Wisconsin Porcelain Co, Sun Prairie, W, elec fence insuls
WISP	ditto
WIS - P - C.	ditto
WOODIN	Wood Electric Co, C W, New York, NY, specialties
W P	unattributed, knobs
W. R. CO.	Wheeler Reflector Co, Boston, porcelain sockets
W S	unattributed, wall tubes
	unattributed, standard porcelain
W S CO.	unattributed, standard porcelain
W. T. Co.	Wheeling Tile Co, Wheeling, W Va, standard porcelain
W. VA. P. CO.	West Virginia Porcelain Co, New Haven, W Va, standard porc
YOST	Yost Electric Mfg Co, Toledo, Ohio, specialties
	unattributed, early 1890's cleats
	Star Porcelain Co, Trenton, NJ, standard porcelain
	Diamond Porcelain Co, Trenton, NJ, standard porcelain
	unattributed, rack spools
	Delta-Star Electric Co, Chicago, poleline hardware
	Anchor Electric Co, Boston, early wiring cleats
	ditto
	Electric Service Supplies Co, Phila, Pa, line insulators

The following companies sold wiring devices and electrical equipment which probably involved porcelain fittings or insulators. They are listed as a possible aid to attributing porcelain markings used by the companies but which are unrecorded to date.

Austin Co, The M B, Chicago, conduit & entrance bushings, wiring devices
Barnard & Co, B S, New York, NY, rack insulators
Bowie Switch Co, San Francisco, Cal, primary fuse cutouts
Caldwell & Co, Inc, Edward F, New York, NY, conduit box rosettes
Cole & Co, Henry, Boston, Mass, wiring devices
C & P Electric Works, Inc, Springfield, Mass, porcelain bushings
Cusack Co, Thomas, Chicago, sign receptacles
Danbury Electric Mfg Co, Danbury, Conn, wiring devices
Dexter-Reynolds Mfg Co, Inc, Chicago, porcelain cleats
D & W Fuse Works (G. E. Co.), Providence, R I, cutouts, wiring devices
Ericson Mfg Co, Buffalo, NY, tel & tel lightning arrestors
Essex Mfg Co, Newark, NJ, lightning arrestors
Estes & Sons, E B, New York, NY, tree insulators
General Devices & Fittings Co, Chicago, bushings, clamp insulators
Harvard Elec'c Co, Chicago, cutouts, arrestors, conduit items, wir'g dev.
Hebendahl Co, J P, Elizabethport, NJ, clamp insulators
Hi-Voltage Equipment Co, Cleveland, Ohio, primary fuse cutouts
Holtzer-Cabot Electric Co, The, Boston, tel & tel lightning arrestors
Machen Electric Mfg Co, Phila, Pa, cutout bases, wiring devices
Majestic Elec'c Mfg Co, St Louis, cleat rosettes, switches, sockets, etc.
Mathews & Brother, Inc, N W, St Louis, Mo, primary fuse cutouts
Metropolitan Electric Mfg Co, L I City, NY, rack & conduit insulators
Moloney Electric Co, St Louis, Mo, primary fuse cutouts
Ragotzky, C A, Phila, Pa, angle porcelain
Rush Bros Co, Chicago, porcelain lighting fixtures
Sears, Henry D, Boston, wiring devices
Southern Elec'l Porcelain Co, Erwin, Tenn, standard porcelain (Porc mfr)
Stomberg-Carlson Tel Mfg Co, Rochester, NY, tel & tel insuls & arrestors
Technical Ceramics & Lava, Fairfield, NJ, electrical porcelain insulators
United Electric Apparatus Co, Boston, sign receptacles, signal apparatus
Ward Electric Co, Inc, Phila, Pa, standard porcelain and specialties
Windman-Goldsmith, Inc, Perth Amboy, NJ, wiring devices

FIBRE & COMPOSITION INSULATORS

Hundreds of companies have manufactured molded insulation of various forms for use with electrical equipment. The following companies are the ones believed most likely to have manufactured composition insulators related to power distribution applications.

AICO	American Insulator Co, New Freedom, Pa
AETNA	Anderson Mfg Co, Albert & J M, Boston, strains, pin types
ELECTROSE	Electrose Mfg Co, Brooklyn, all forms of line insulators
ARCOVER	ditto
ELECTROBESTOS	Johns-Manville, Inc, New York, NY, line insulators
NOARK	Johns-Pratt Co, Hartford, Conn, line insulators
MOULDED MICA	ditto
MACALLEN	Macallen Co, The, Boston, mines, strains, third rail
DIRIGO	Ohio Brass Co, Mansfield, Ohio, strains, mines, pin types
SHAWLAC	Shaw Insulator Co, Newark, NJ
W	Westinghouse Electric & Mfg Co, E Ptsbg, Pa, line insuls.

LAVA INSULATORS

Lava is the mineral steatite -- hydrated magnesium silicate. In the natural state it can be machined as easily as brass to almost any desired shape. After machining it is fired at 1100° C to extreme hardness. Lava composition, made of crushed steatite with a suitable binder may be made in many forms by molding and then firing, and it has nearly the same good characteristics as solid lava.

Lava insulators are used mainly where heat conditions are severe and where dimensional stability under wide temperature ranges is important. Although this is not true for most power distribution insulators, some of the companies manufacturing lava insulators have made some forms of power distribution insulators. The major companies operating in the era when this occurred are listed below as a possible reference.

LAVA	American Lava Corp, Chatanooga, Tenn
- -	Downey Co, Gilbert H, Phila, Pa
LAVAROCK	Kirchberger & Co, Inc, M, Brooklyn, NY
CRESCENT	ditto, arc light insulators
LAVITE	Steward Mfg Co, D M, Chatanooga, Tenn
XL	Tennessee Burner Mfg Co, Chatanooga, Tenn

Chapter 6

INSULATOR PATENTS

THE SEARCH

Considerable insight into the history of an industry can be obtained by a thorough search and study of the patents on the items. Additionally the patents also fill in many missing dates, names and locations. Once this became evident, I spent several thousands of hours over a period of four years researching the insulator patents -- probably twice the time I spent in other forms of research on electrical porcelain.

The patent data gathered were restricted to actual insulators and related items which pertained to power transmission or distribution from the pole lines to the low-voltage current outlets. Even at that, data were not kept on a number of very large classes of insulators except for items important to insulator collectors. For instance, no data were kept on many hundreds of patents relating to designs of suspension insulators and multipart pin types, or manufacturing processes for them. Similarly the files would have been choked if data had been kept on the hundreds of varieties of wireholders, insulator pins and brackets, etc. One company alone had dozens of patents on just wireholders.

At the outset of this work, a card was designed to uniformly tabulate the patent data, and this is illustrated below. A projection method

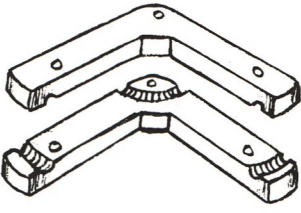
# 911,429	2-2-09	138 VOL.	136 PAGE		3 TOD	GAZ.	PAT.
Cl. 174-157		Inv.: Roderick McLennan, Ballston Spa, NY					
ITEM: Cleat for elec'c wiring							
SPEC.:							
<i>For turns or bends in wiring route.</i>							

was devised to copy onto the cards the small drawings from the Official Gazettes (O.G.) of the patent office, and notes were made from the patent claims (usually written in archaic Greek or Chinese) to briefly explain the workings of the device. In some cases where the drawings and claims defied decoding, the complete patent specifications were consulted.

It rapidly became difficult to group the hundreds of cards in some order and to find items by type. The official patent office classificat-

ion system is hopelessly useless for this -- also being written by the combination of Greek, Boolean algebra and second-guessing. I devised my own classification system which groups items by style or usage, and this system of classes is shown on page 125. All patents tabulated herein are grouped by these particular "Tod Classes".

If you have never searched patents, you couldn't imagine the voluminous amount of material involved. Library stacks 8 shelves high stretch out in long rows to hold just the Official Gazettes. Bound copies of the "Specifications" for just one year in the early 1900's take over 100 feet of shelf space. Looking piecemeal for certain patents, especially ones we don't even know to exist, is truly like looking for a needle in a gigantic haystack. So, where do you start? Well, you could start at one end of the stack and remove one straw at a time until you moved the whole stack and found all the missing needles. I came close to doing that!

First, I checked from 1836 thru 1959 all of the subclasses 139 thru 212 of major Class 174. This was only 2946 patents. It seemed hopeless to check all the reference classifications the IBM computer sheets spit out of the microfilm files.

Then the yearly indexes were checked from 1880 thru 1962, and even the indexes couldn't all be loaded into a pickup truck. The patents are listed alphabetically by invention name -- and therein lies a gigantic problem. The inventions bear names which sometimes have nothing to do with the insulator kingdom. I methodically checked each yearly index against a long list of most probable names: Insulator (of course), tube, knob, cleat, fastener, support, telegraph, telephone, wiring, electrical, electric, block, wireholder, fuse, cutout, rosette, switch, etc. etc.

Needless to say, many of the "knobs" I looked up had something to do with dresser drawers, and "wireholders" sometimes had something to do with stringing barbed wire fences. Nevertheless, this drawn-out search did uncover several hundred more patents not found under the patent office's fancy classification system. All of the indexing and making of yearly sequential lists was done at home in the evenings, while complete days at the distant libraries were spent only in studying the patents.

After the patent searching was completed, I repeated nearly the same process to search for all insulator trademarks registered from 1880 thru 1962. Although the search was equally exhaustive, it entailed considerably less total time and paper shuffling.

My card file on insulator patents is most certainly the most extensive patent file among insulator historians and collectors. In addition to the card file with rather complete notes on each patent recorded, there are worksheets with patents listed sequentially and giving dates, names and some notations on several thousands of patents studied but which are not included in my patent card file.

This book is being used as a vehicle to publish tabulations of many of my carded patents which would be of interest to other researchers on insulators but which are not related to the dry process electrical porcelain industry covered in the history sections of this book. Hopefully these published lists will make it unnecessary for other researchers to duplicate the exhaustive search I have already made. And for this same reason, patents are included on certain radio antenna insulators which are of interest to collectors but have nothing to do with power wiring.

BETTER MOUSE TRAPS

Patents are supposed to privilege inventors the exclusive manufacture of an item for a term of 17 years, after which time everyone else may horn in on the act. You don't have to invent something radically new. You may merely find a cheaper, simpler or more efficient device than that which is already patented -- that is, better mouse traps.

Many times when you contrive some gadget to do some chore around the home, all the neighbors automatically say, "Great, why don't you get a patent on that?" You should answer by asking them, "But, why should I?" See if they go blank for a logical answer! It costs several thousands of dollars to obtain even a very simple patent. There's no reason for trying to get a patent on any scheme, regardless of how ingenious it is, if you don't intend to manufacture it and if it wouldn't sell if someone else might be interested in manufacturing it. Of course, it may be worth a few grand to you to have the wife tell the bridge party, "Oh, Harry was granted his second patent last week."

I am convinced that you can't just sit down with the purpose of trying to invent a better mouse trap. Worthwhile inventions are flickering inspirations. They arise accidentally. A workman may struggle with some repetitive chore for years and then have it come to him in a flash of how to do the job much easier or in a better way.

The output of Edison's Menlo Park, N.J. laboratories might appear to refute the above statement, but I stand by it. His "inventions" were the product of dogged research and development on schemes which were known to be feasible but which hadn't been worked out. Some, such as the phonograph, came about by pure accident in his labs.

It is interesting when searching the insulator patents to sort them all out as to their reason for being. You immediately discover that few of them show any real ingenuity. Few are really clever. Rarely do they do something better than what is already in use for the purpose. Many are simply the product of one's dreaming up something that would work, regardless of how cumbersome it might be, and then responding positively to the old question, "Why don't you get a patent on that?"

Some of the patents are extremely childish, many are impractical for various reasons, some are for designs that couldn't be made by any method or wouldn't work if they could be made. Would you believe -- insulators with curved, threaded holes which screw onto curved pegs? I can show you the patents on such things. Other than the well published rule about no patents on "perpetual motion schemes", the patent office seemed to have no qualms on granting patents for impossible schemes. If you applied for a patent on a curved gun barrel that would shoot bullets around in large circles, you'd get a patent granted -- and your patent attorney would be laughing all the way to the bank.

Although some insulator patents covered true invention of novel and useful gadgets, many insulator patents were secured as a means of entry into an already overcrowded manufacturing and sales field. If you could stamp your nail knobs with a patent number or date, they might sell much better. If it's patented, it must be something new and better?

In the 1900-1920 period, dozens of small companies were starting up to manufacture wiring cleats and nail knobs. Virtually every conceivable form of nail knob had already been patented, and the basic patents were not old enough to have expired yet. So what now? Simple. Design your own nail knob with some picayunish detail claimed as an improvement and apply for a patent on it. If others captivated the top with a washer, a spring, a winged-nail, a piece of glue -- or if others used a round nail, a square nail, a bent nail or whatever -- well, geewhiz, ours uses a nail

with a touch of glow-paint on the head so you can see it better in dark corners of the attic when wielding the hammer. We're now in business, and tell the shipping department to stamp all boxes "Patent Pending".

There was no end to this. A patent no longer protected the real inventor. Anyone could get a patent on essentially an identical item and start production immediately. Nearly all of the nail knob patents shown herein should not have been granted a patent. Some are identical, even if you study the claims with a fine-toothed comb. If you invented something really novel and patented it, someone next month would be making the identical thing (with glow-paint on the nail head, of course).

Several classes of patents are interesting in that they show a prolonged desire to alleviate some frustrating problem, and a few examples will be given below.

If you've ever tried to hammer in nail knobs over your head on a rafter, you'll see why everyone strived to find a good way to captivate all the pieces together, and also why there were so many patents to align the cap to the base part. And then all those patents for wall tubes, to devise some means to keep them from falling out of the hole, or to put them in place after the wire was already installed through the hole.

There were many forms of cleats and self-tying knobs designed so as to make it possible to install all the knobs and then run in the wires. Several were rather ingenious, but many were hopelessly impractical.

The biggest example of frustration and boredom on the part of those who installed insulators is shown by all the patents for pin types which secure the conductor without using a tie wire. There are at least two hundred patents on such designs (read the lists!). Possibly a million or more lineman stood on climbers atop poles for 100 years tying wires onto countless millions of insulators; they had plenty of time to think about, "There must be an easier way to do this." We need a "better mouse trap".

I regret that drawings of all these self-tying pin types cannot be shown in this book ostensibly devoted to "standard porcelain". They are extremely interesting. A few show some ingenuity, but most of them are hopelessly childish, impractical, unworkable, very expensive, unreliable, or even much more complicated to install than using a tie wire.

Even though thousands of engineers and lineman dreamed up schemes to eliminate tie wires, and hundreds spent money to get patents on schemes, we are still today (near the demise of pin types) using tie wires. Seems nothing else works so good, so cheap, so easy, so reliable. Inroads have been made by clamp-top power insulators in the last 40 years, and these may soon become the standard, but the self-tying insulator for telegraph and phone lines just never made it before the lines were doomed to underground cables and microwave transmission methods.

Some specimens of self-tying cleats, knobs and pin types are extant, showing that at least someone down the line thought they would sell, but most are of comparatively early vintage, and most are scarce or rare. The big majority ever made have probably long since gone to the town dump. Odd specimens do continue to turn up, and these are usually attributable as to patent or inventor and manufacturer by consulting my card file of patents, partially included herein. It would be a rarity for an oddball self-tying pin type specimen to show up which wasn't patented.

ABOUT PATENT PROCEDURES

U.S. Letters Patents grant the inventor exclusive right to manufacture, sell or use a new and useful invention. In the United States the patent is for 17 years and it may not be renewed. Serious omissions or errors, if promptly noticed, can be corrected with a Reissue Patent dated later than the original patent. U.S. patents afford no protection in foreign countries but "International Union" agreements give the inventor priority in the filing of foreign patents on the item. The inventor need not manufacture or operate under the patent, but he must mark the patent date or number on what is produced and must stop infringers, otherwise his monopoly lapses.

Design Patents grant exclusive rights to the originator of an "ornamental design" of manufactured objects and not to their structural design. Even when a Letters Patent covers the mechanical novelty, a Design Patent might be obtained to protect against imitations if the design is a distinctive one. In the case of insulators, some design patents were obtained (especially on guy strains) where no novelty was involved other than a specific shape of insulator. Design Patents may be for periods of $3\frac{1}{2}$, 7 or 14 years, at the option of the applicant. They may not be extended or renewed.

Trademarks are distinctive marks or names which identify goods made or sold by a particular trader and which distinguish the goods from other goods of a similar nature. The U.S. Patent Office will register and give certificates for Trademarks under a broad set of rules and guidelines. The certificates run for periods of 20 years and are renewable.

The Patent Office issues weekly an Official Gazette (O.G.) which gives an abridged description of each patent issued during the weekly period (also Designs, Trademarks, Prints, Labels, etc.). The issuing date of each O.G. and the granting dates for all patents is always on a Tuesday, regardless of date. The fact that many patent dates naturally fall on Christmas and other holidays is of no consequence, since that was the Tuesday which ended one weekly period of publication.

Each year an "Annual Report" (annual index) is issued. It tabulates all patents issued during the preceeding year, alphabetically by name of inventor and name of invention. It lists the patent number and date, the weekly volume and page number in that volume.

There are many official depositories for these issuances from the patent office, including all state capitols, most of the larger universities, some of the larger colleges. Some public libraries are listed as depositories, and others may have partial or complete sets of the O.G. & Indexes. Any large library should be able to advise you of the nearest depository. Generally any collections of the O.G., even if complete, are worthless unless they have the Indexes (annual reports) which are necessary to locate the patents if the patent date or number are unknown. Some sets of patent publications are available in industry, law offices, etc., anyone regularly paying the large subscription fees involved.

Looking up any patent in the O.G.'s is simple if the patent number is known. It is relatively easy if the date and inventor's name are both known. It is possible, although time-consuming, to find it in the 1,000 or so patents issued for one week if you know only the date. More often than not, insulator specimens are marked with the patent date only, not the number. If you know the item was patented but do not know the date, number or inventor's name, it's usually a hopeless task. It is possible that people who have done patent searches professionally all their life might locate the patent, but I assure you the patent office classification system and listings of search classes within same will be completely

unfathomable to the lay person.

Complete copies of the patents can be obtained from: Commissioner of Patents, Washington, DC 20231. Send either (1) the patent number, or (2) the full name of the inventor and the patent date. If you want to press your luck, send only the name of the inventor and the approximate patent date. The copies are ~~50¢~~ each, and expect delivery of 1 to 3 months.

Many patent dates appearing on specimens are in error or partially illegible. Sometimes the correct or full date can be deduced by knowing that all patent dates are Tuesdays. The chart I have concocted in the Appendix lists the dates of all Tuesdays from 1836 to the year 2000, and this has proved very useful in unraveling error markings.

It is also very useful to be able to tell in which year a given patent number falls. The Appendix contains a tabulation of the first number each year for Letters Patents, Designs, Reissues and Trademarks. A similar tabulation by weeks would be even more helpful but would involve 52 times the volume of tables. Obviously only professional patent searchers would make such tabulations.

For those wishing to make patent searches to determine prior patents issued for given items, or to try to locate the patent on an item when neither the patent number, date or inventor's name are known, one must employ the patent office classification system. The patent office list of classification definitions for Class 174 (Electricity, conductors and insulators) is 36 pages long and is about five times more difficult to comprehend than a full set of income tax forms for General Motors. I've attempted to boil this down into 3 pages which is possibly comprehensible to collectors and casual researchers, and this is included in the Appendix. Only the major subclasses 137 thru 212, plus subclasses 2, 32 and 40 are of primary interest to insulator collectors.

First, you must attempt to deduce in which subclass the insulator would be included -- such as Class 174-141. There exists an IBM printout annually which lists all the 4 million odd patents by their classification definitions. This is available in libraries on microfilm, if they do have it at all, and it might not be too recent a year's vintage. It will show you all patents ever granted which fit into Class 174-141 that you wish to search. This may be only several, but more likely hundreds.

Additionally, some inventions may have features which would place it in more than one classification or subclass. It is placed in the class or subclass deemed most prominent in the invention, and the "reference" classifications are listed on a separate printout (on microfilm). Thus, for your Class 174-141, the "reference" classifications would list all other patents in other classes which should also be searched. This list is usually even larger than the original class under search.

If you have a strong desire to search out a patent on a given item, and if you have lots of time and patience, you may have success. Before it's over, you may find that it would have been worthwhile to pay a fee to a professional searcher to locate the patent on the item.

PATENTS WITH ILLUSTRATIONS

The "Tod Classes" of patent identification are listed at the bottom of this page. On the following pages, all the patents from 1880 through 1962 which are of interest to insulator collectors and pertinent to those histories included in this book are tabulated. Each patent is identified by number, date, inventor(s) name, assignees (if any). A brief description of the patent is given if it isn't obvious from the drawings.

Explanatory drawings are given for Classes 1 through 26, plus Classes 35 and 36. Some other patents, especially in Class 40, are pertinent to the histories in this book, but there had to be a limit to the number of drawings included. The patents in the remaining classes are merely tabulated with very brief descriptions of the main patent feature. Classes 80 through 88 are not tabulated, since they are very numerous and aren't nearly as pertinent to the content of this volume. All tabulated patents are those from my card file of patent information, and none are from my worksheets which contain some reference information on more than 3,000 other patents on insulators and related items.

The drawings are essentially tracings of those on my file cards and which, in turn, were copied from the O.G. drawings. Quality, scale and drawing methods vary among the patents -- all being made by different draftsmen over a period of many years. Most knobs and cleats were meant to be ceiling mounted. Some are depicted that way, but many are inverted in orientation as to the mounting surface.

TOD PATENT CLASSIFICATIONS

1	Cleats, two-piece reversible	36	Bushings for holes & conduits
2	" , multi-piece nonreversible	40	Miscellaneous non-pintypes
3	" , corners and ridges	46	Transpositions, all types
4	" , one-piece and specials	50	Misc. pin types and processes
6	Knobs, split, square and round nail & screw knobs	52	Oil resevoir, dry-spots, etc.
7	" , split, reversible	53	Fogs, Helicals, Hi-Tops, etc.
8	" , split, special	54	Upside-down under crossarms
10	Knobs and Cleats, self-tying	55	Self-tying, twist-lock or slack-wire types
12	Crossovers	56	Self-tying, fingers, or types which bend conductor
14	Knobs using tie wires	57	Self-tying, top cap screws on
15	Wireholders and similar	58	Self-tying, miscellaneous types
16	Insulator blocks held in clamps	60	Tie-wire clips, clamps & bails
18	Clamp types and rack insulators	62	Protective shields over glass
20	Slack-wire knobs and spikes	64	Wire-groove protector bands
22	Grossarm "block" types	66	Metal/composition combinations with top cable clamps
24	Swinging tree types & hangers	80	Pegs and pin brackets
25	Miscellaneous tree insulators	82	Sleeves to surround pins
26	Mine insulators & their pins	86	Suspension type insulators
28	Strains and break knobs	88	Crown clamps and metal caps
32	Knob-mounting brackets & clips		
35	Wall tubes		

Note: Parts of Class 46 and all of Class 88 and Classes 50 through 82 pertain to pin type insulators.

CLASS 1 -- Cleats, two-piece reversible.

458,964	9-1-91	Electric wire cleat, H P Ball, Brooklyn, NY
502,614	8-1-93	Cleat for insulated wires, E H Clarke, Lynn, Mass., assr $\frac{1}{2}$ to S Eaton, Boston, Mass.
508,687	11-14-93	Cleat for electric wiring, F A Duggan, Trenton, NJ
518,301	4-17-94	Ceiling-cleat, H C Wirt, Boston, assr to G. E. Co.
544,501	8-13-95	Cleat for holding electric wires, E W Buffinton and A F Dow, Fall River, Mass. ("B & D" cleat)
575,090	1-12-97	Cleat, C F Adam, Trenton, NJ (Corrugated grooves.)
631,234	8-15-99	Cleat for electric wiring, H M Stevens, Boston, assr $\frac{1}{2}$ to Petingill Andrews Co., Boston
769,639	9-6-04	Cleat for electric conductors, H R Sargent, Schenectady, NY, assignor to G. E. Co.
1,042,677	10-29-12	Insulating-cleat, R D Hilty, Carey, Ohio, assignor $\frac{1}{2}$ to Ira N Zeis, Carey, Ohio
1,163,114	12-7-15	Insulator, L Stahl, Carey, Ohio
1,178,539	4-11-16	Insulator, F Schaub, Jersey City, NJ

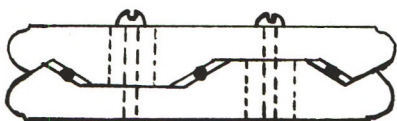

458,964

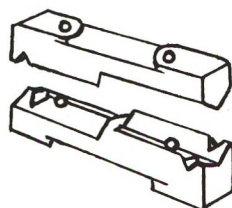

518,301

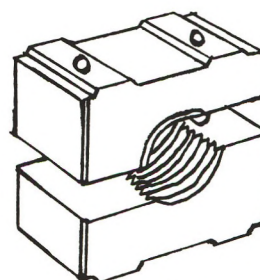

769,639



502,614

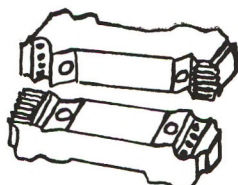

544,501

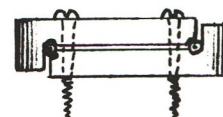

1,042,677

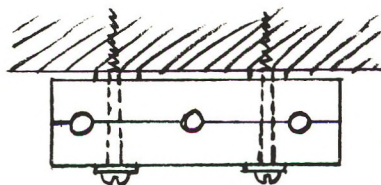
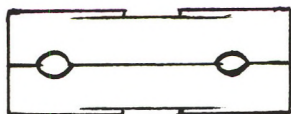

575,090

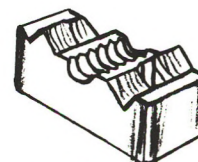

1,163,114

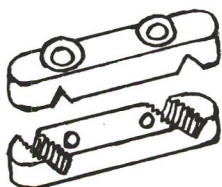

508,687

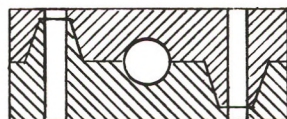

631,234

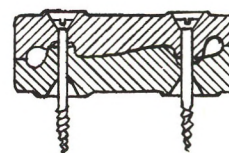

1,178,539

CLASS 2 -- Cleats, multi-piece nonreversible.

- | | | |
|---------|---------|--|
| 324,692 | 8-18-85 | Insulator for securing telegraph and other wires, G W Hill, Quincy, Mass. (Rigid top plate squeezes wires between soft and yielding insulator sections.) |
| 411,801 | 10-1-89 | Wire holder & insulator, J R Fletcher, Dayton, Ohio |
| 476,827 | 6-14-92 | Wire-cleat, A P Seymour, Syracuse, NY (Clamping jaws entire length, bending wires when in place.) |
| 503,384 | 8-15-93 | Cleat for electric wires, J P Pawolowski, Cincinnati |
| 505,215 | 9-19-93 | Cleat for holding a plurality of insulated electric wires, E W Buffinton, Fall River, Mass., assr $\frac{1}{2}$ to A F Dow, same. (Continuous longitudinal grooves.) |
| 505,912 | 10-3-93 | Cleat for holding insulated electric wires, E W Buffinton, Fall River, Mass., assr $\frac{1}{2}$ to A F Dow, same place. (Transverse ribs on mounting base.) |
| 527,254 | 10-9-94 | Insulator, W D Trimble, Baltimore (Both pieces have flange, one or more grooves, fitting one in other.) |
| 531,702 | 1-1-95 | Cleat for electric wiring, J H Swift & W F Maintien, Plainville, Mass. (Cornering grooves in bottom half and grooveless top. Convex surfaces, bends wires.) |
| 558,165 | 4-14-96 | Electric-wire cleat, F B Evans, Clinto, Mass., assr $\frac{1}{2}$ to T Gould, Boston, Mass. |

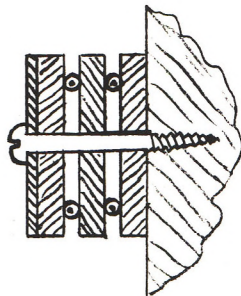

324,692

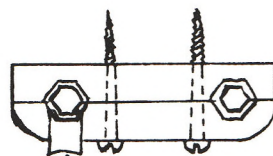

503,384

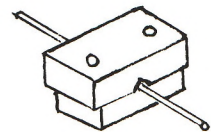

527,254

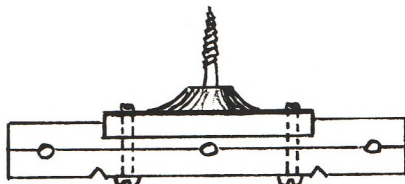

411,801

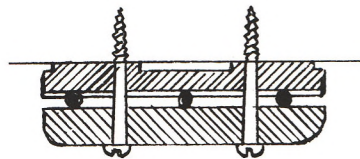

505,215

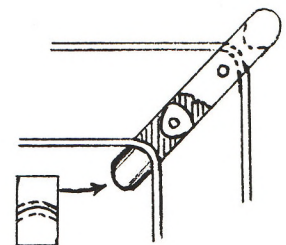

531,702

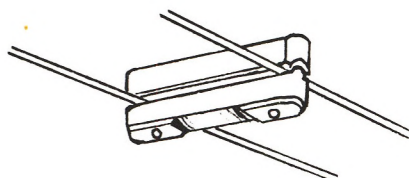

476,827

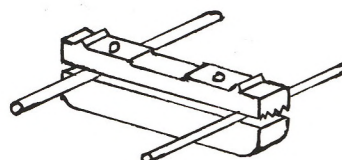

505,912

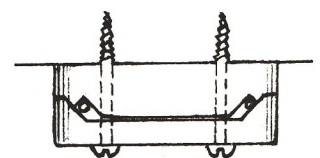

558,165

CLASS 2 (continued)

- 818,186 4-17-06 Insulating-cleat, H D Murdock, Wilkinsburg, Pa. (Top piece grooves different for different wire sizes.)
- 872,993 12-3-07 Insulator, A S Deem, Reading, Pa., assr ½ to I Bear, same place. (Two pairs of register grooves spaced apart and which don't extend to the ends.)
- 910,975 1-26-09 Cleat for elec'c wires, A L Vickers, New Sharon, Ia. (Three-piece top, each part independently removable)
- 911,864 2-9-09 Porcelain cleat, E Ball, Cedar Rapids, Ia. (Mortised slot on plane-surface base. Two independently removable caps have tenons which fit into mortise.)

CLASS 3 -- Cleats, corners and ridges.

- 869,163 10-22-07 Cleat for corner edges, W J Devibe Norwalk, Conn.
- 911,429 2-2-09 Cleat for electric wiring, R McLennan, Ballson Spa, NY (For turns or bends in the wiring route.)
- 1,048,736 12-31-12 Insulating-cleat, B Richards, Canton, Mass.

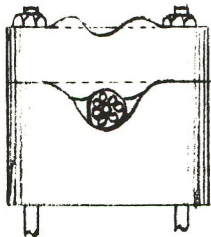

818,186

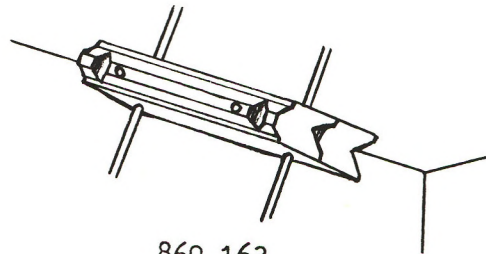

869,163

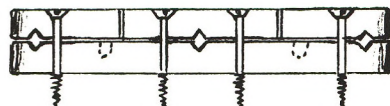

910,975

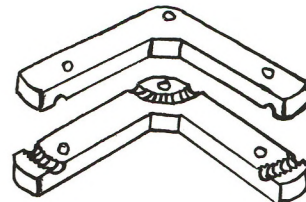

911,429

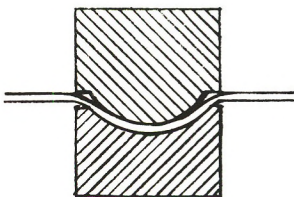

872,993

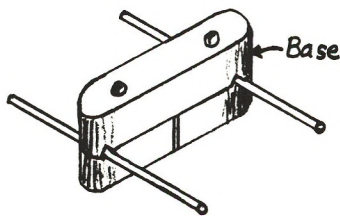

911,864

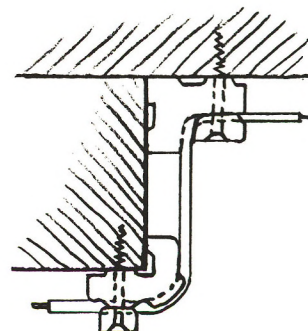

1,048,736

CLASS 4 -- Cleats, one-piece and specials.

271,825	2-6-83	Fastening for electric-circuit wires, H G Fiske, Springfield, Mass. (Earliest patented cleat.)
422,651	3-4-90	Insulator, G E Stanley, Whitman, Mass. (Resilient jaws. Mounting screws clamp wire between jaws.)
433,651	8-5-90	Cleat for electric wires, L Furlong, Hartford, Conn., assignor to F C Rockwell, Hartford
444,317	1-6-91	Elec'c-wire insulating-cleat, J S Potter & D C Cartwright, Boston (Wedges for tapered wire grooves.)
497,515	5-16-93	Insulator, T H Brady, New Britain, Conn.
504,059	8-29-93	Insulator, G W Blackburn, Palmyra, NY
518,907	4-24-94	Cleat for supporting conducting wires for electric circuits, H B Wymna, Slingerlands, NY, assignor $\frac{1}{2}$ to A C Goodwin, Albany, NY
539,040	5-14-95	Insulator, L H Des Isles, Boston, assignor $\frac{1}{2}$ to F S Palmer, Boston, Mass.
551,032	12-10-95	Cleat for electric wiring, J R Hemphill, Akron, Ohio

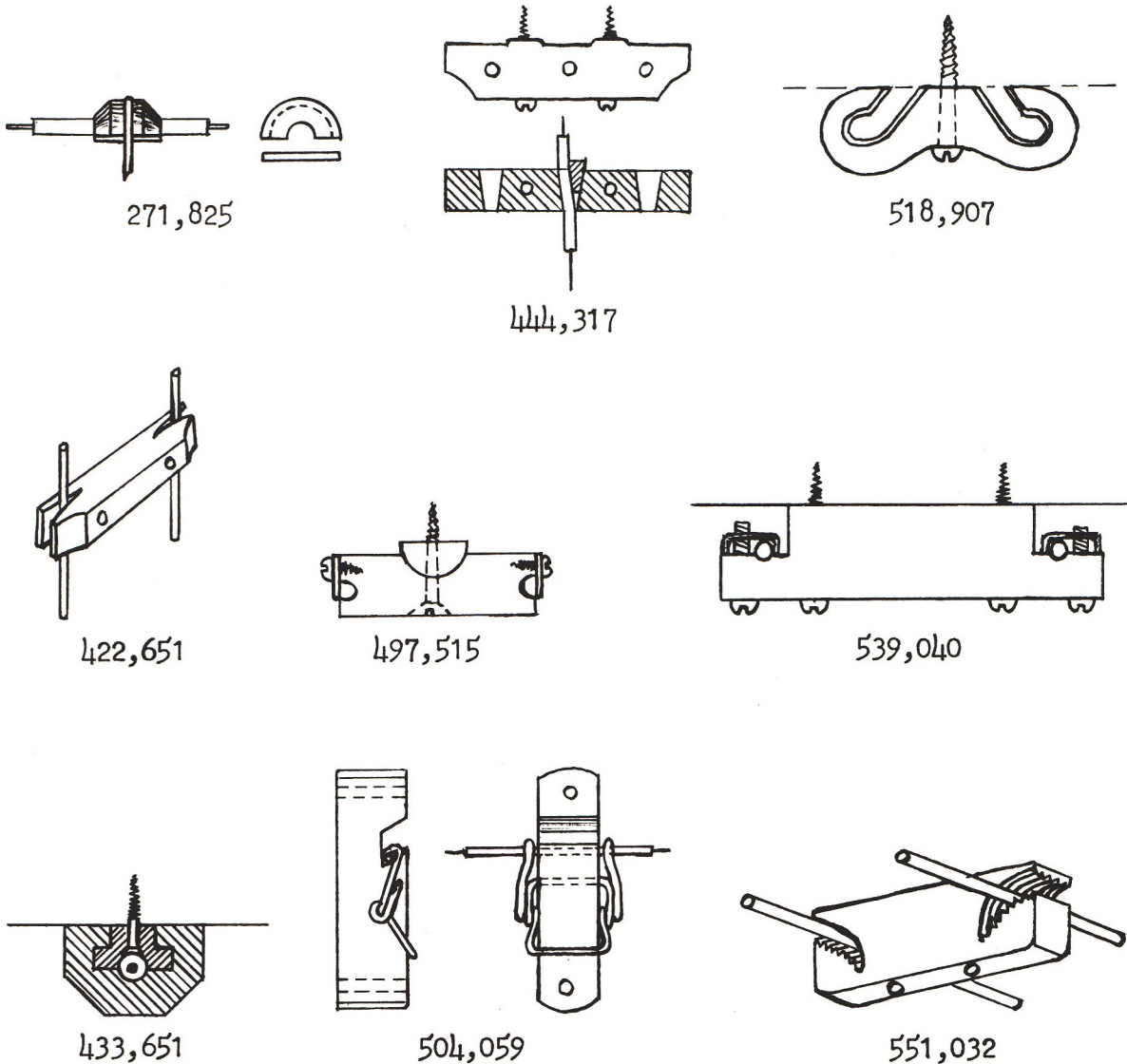

CLASS 4 (continued)

- 682,831 9-17-01 Adjustable insulator, H D Murdock, Pittsburg, Pa.
 (Series of split knobs, each with different groove sizes to accomodate different wire sizes.)
 934,463 9-21-09 Cleat for electric wires. W F Ritter, Cincinnati
 978,941 12-20-10 Combined cleat & rosette, F Schimpf, St. Louis, Mo.

CLASS 6 -- Knobs, split, square & round nail & screw types.

- 296,688 4-8-84 Insulating-support for elec'c conductors, D S Haines & S D Lake, Brooklyn, NY (Earliest patented "nail knob". Bracket for this is Pat #296,558, same date)
 398,025 2-19-89 Insulator, W C Brown, Tarrytown, NY (Side saddle.)
 440,042 11-4-90 Insulator for electric conductors, W Kessler, Lafayette, Ind. (Cap reversible, thus 1 or 2 grooves.)
 531,635 1-1-95 Electric-conductor holder or insulator, A Iske, Lancaster, Pa.
 753,398 3-1-04 Cleat for elec'c wiring, E C Hunt, Belle Plaine, Ia, assr 1/2 to C Snyder, Benton County, Ia. (Side saddle)
 776,514 12-6-04 Cleat for electric wiring, E C Hunt, Belle Plaine, Ia. assr 1/2 to C W Snyder, Belle Plaine, Ia. (Groove for registry opposite wire groove slots.)

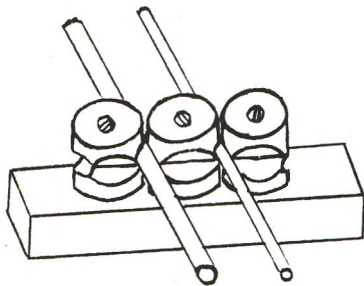

682,831



296,688

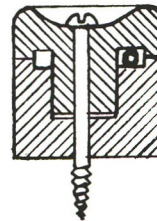

531,635



934,463

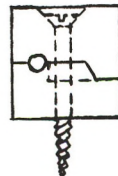

398,025

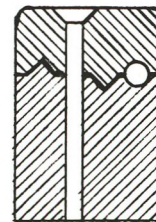

753,398

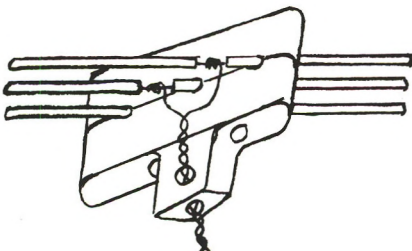

978,941



440,042

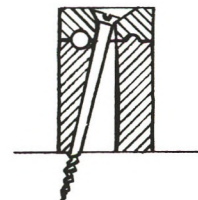

776,514

CLASS 6 (continued)

806,588	12-5-05	Electric insulator, H Sinclair, Trenton, NJ (Oval.)
825,954	7-17-06	Cleat for electric wires, C C Blake, Brookline, Mass (Specifies wood, grain parallel with axis, grooves in bottom of cleat to hold the wires.)
845,544	2-26-07	Wiring-knob, W C Gordon, Windsor, VT., assr to The Electric Good Mfg Co, Maine (Radial corrugations on periphery of cap at the mating surface.)
864,947	9-3-07	Clamp for electric conductors, E W Buffinton, Fall River, Mass. assr ½ to Marietta M Huggett, same.
876,059	1-7-08	Split knob, W H Irons, Beaver, Pa.
907,251	12-22-08	Electrical-wiring knob, H W Lawrence, Denver, Colo.
917,207	4-6-09	Insulator, A Weber, Jr., Schenectady, NY, assr to A Weber, Sr., same place. (Registry groove between hole and wire groove. Side saddle type.)
919,386	4-27-09	Insulator, F Schaub, Jersey City, NJ
981,074	1-10-11	Split-knob insulator, H D Dupont, Indianapolis, Ind.
1,014,934	1-16-12	Insulator-knob, G Baker, Torrington, Conn. (Short spring at base captivates the screw.)
1,021,059	3-26-12	Insulator, W R Markley, Findlay, Ohio

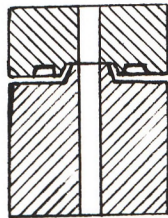
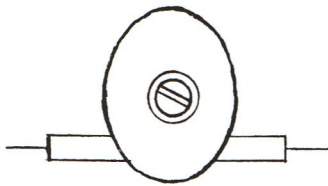

845,544

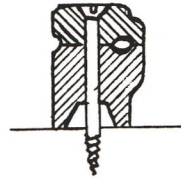

907,251

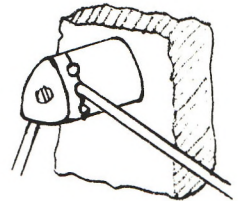

981,074

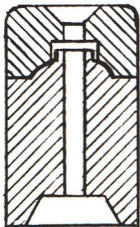

806,588

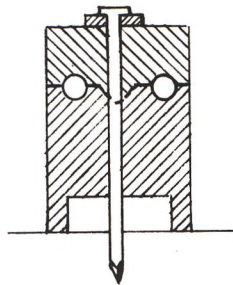

864,947

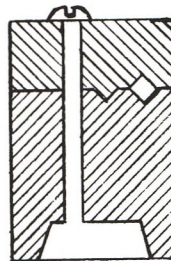

917,207

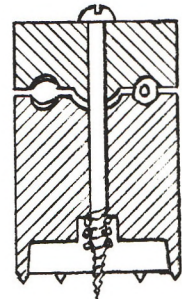

1,014,934

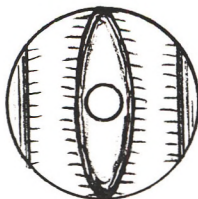

825,954

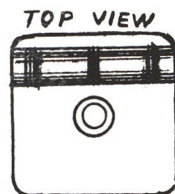

876,059

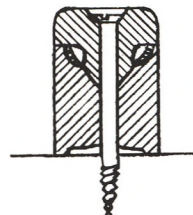

919,386

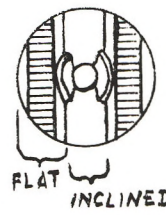

1,021,059

CLASS 6 (continued)

- 1,042,372 10-22-12 Split insulator, J R Harris, Allegheny County, Pa. (Captive top. Fin on cap stem off center and will enter & come out in only one position.)
- 1,048,850 12-31-12 Insulator, J W Moore, Carey, Ohio (Conductor wire will pull through straight, but jams otherwise.)
- 1,049,405 1-7-13 Insulator, F Schaub, Jersey City, NJ
- 1,061,620 5-13-13 Insulator, H R Markel, Columbus, Ohio
- 1,079,239 11-18-13 Insulator, J R Harris, Crafton, Pa. (Metal tube, both ends upset, captivates top cap to base.)
- 1,217,315 2-27-17 Insulator, J H Kendig, Pittsburgh, Pa. (Adhesive in base captivates nail, gives way when driven in.)
- 1,218,181 3-6-17 Insulator-knob, J W Homer, Greencastle, Pa. (Captivated washer held by ribs in base recess.)
- 1,232,354 7-3-17 Insulator, J E Mair, Pittsburgh, assignor to The Brunt Tile & Porcelain Co., Columbus, Ohio
- 1,273,313 7-23-18 Insulator, T W Beatty, Carey, Ohio (Spring clip captivates cap to base, rotatable to insert wire.)
- 1,290,540 1-7-19 Knob-insulator, G Glocker, North East, Md.
- 1,302,158 4-29-19 Insulator, J R Harris, Allegheny County, PA (Nail & its hole rectangular, serving to align cap & base.)

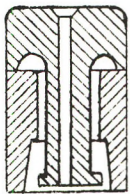

1,042,372



1,061,620

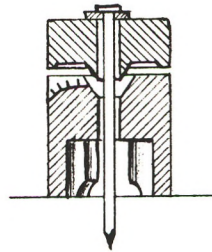

1,218,181

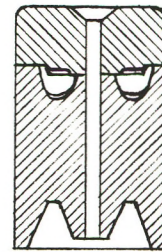

1,290,540

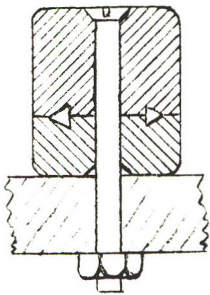

1,048,850

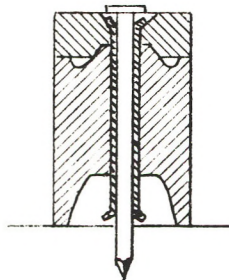

1,079,239

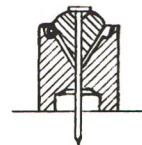

1,232,354



1,049,405

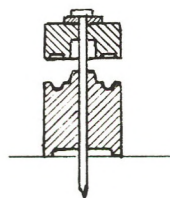

1,217,315



1,273,313

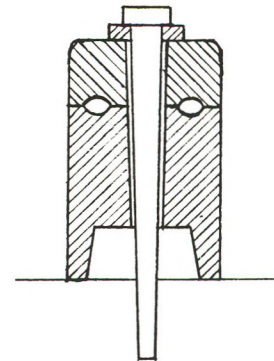

1,302,158

CLASS 6 (continued)

- 1,311,483 7-29-19 Insulator, F Amos, Wheeling, W Va, assr to Wheeling Tile Co., same place. (Cap has radial ridges flush with rim of cap. Ribbed base grooves.)
- 1,329,656 2-3-20 Insulator, A H Fargo, Poughkeepsie, NY, assignor to C Tremain (Captivated nail.)
- 1,335,634 3-30-20 Insulator, F M Amos, Wheeling, W Va, assignor to Wheeling Tile Co., same place.
- 1,354,396 9-28-20 Fastening device, H E Hoenig, East Liverpool, Ohio, assignor $\frac{1}{2}$ to J T Smith, same place.
- 1,376,307 4-26-21 Insulator, F M Amos, Wheeling, W Va, assignor to Wheeling Tile Co. (Base hole off center and inclined, putting friction on assembly nail to captivate cap.)
- 1,390,118 9-6-21 Insulator, P C Fridrichsen, Wheeling, W Va
- 1,427,953 9-5-22 Attaching device, A W Harrison, Winthrop, Mass., assr to Porcelain Appliance Corp., Wilmington, Del. (Elastic-material prong on nail captivates assembly)
- 1,429,079 9-12-22 Split insulator, C W Kettron, Macomb, Ill., assr to Illinois Electric Porcelain Co., same place.
- 1,429,369 9-19-22 Attaching device, Wm Morrill Parker, Parkersburg, W Va, assr to J H Parker & Son, Inc., same place. (Filed 1-8-15! Winged nail end captivates cap.)

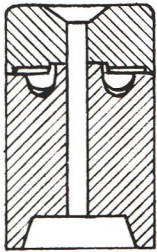

1,311,483

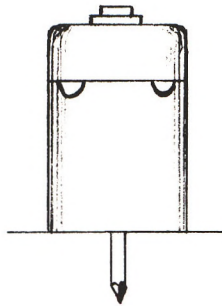

1,335,634

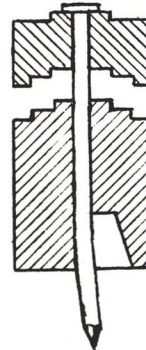

1,376,307



1,427,953

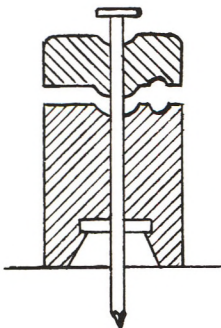

1,329,656

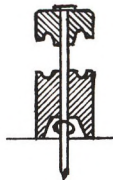

1,354,396



1,390,118



1,429,079



1,429,369

GLASS 6 (continued)

- 1,474,736 11-20-23 Insulator, F Schaub, Jersey City, NJ (Glazeweld captivation breaks apart when installing.)
- 1,521,433 12-30-24 Indicating insulator, R W Charlton, Pineville, La. (Side ridges indicate that grooves are lines up.)
- 1,592,042 7-13-26 Insulator, M Newman, Alameda & Wm Gilardin, Oakland, Cal. (Frangible material between bore and horizontal slot. Becomes 2-piece when nail seated down.)
- 1,602,918 10-12-26 Insulator, W J Martinez, Berkeley, Cal.
- 1,668,581 5-8-28 Electric insulating knob, D M Brown, Prince Rupert, B.C., Canada

CLASS 7 -- Knobs, split, reversible.

- 697,001 4-8-02 Insulator, W H Nichols, Bennington, Vt, assignor $\frac{1}{2}$ to E E Larrabee, same place.
- 878,302 2-4-08 Insulator, H R Markel, Dayton, Ohio
- 971,683 10-4-10 Insulator, H R Markel, Columbus, Ohio
- 992,570 5-16-11 Insulator, H R Markel, Columbus, Ohio
- 1,127,776 2-9-15 Insulator, C W Kettron, Macomb, Ill., assignor to Illinois Electric Porcelain Co., same place.

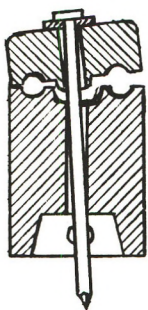

1,474,736



1,602,918

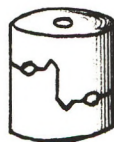

697,001



971,683

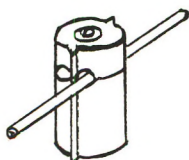

1,521,433

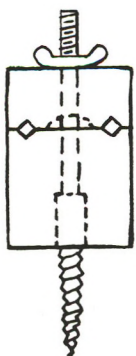

1,668,581

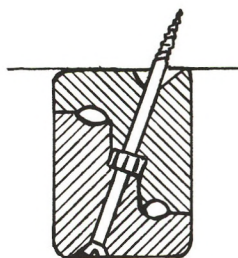

878,302

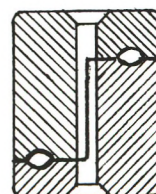

992,570



1,592,042



1,127,776

CLASS 7 (continued)

- 1,139,748 5-18-15 Insulator, T W Beatty, New Cumberland, W Va
 1,144,153 6-22-15 Insulator, W H Nichols, Bennington, Vt. (Two grooves on each surface, for different wire sizes.)
 1,147,498 7-20-15 Divided insulator, E H Freeman, Trenton, NJ, assr to Trenton Porcelain Co., same place.
 1,177,996 4-4-16 Insulator, W J Curry & W A Andrews, E Liverpool, Oh.
 1,201,325 10-17-16 Insulator, H R Markel, Columbus, Ohio

CLASS 8 -- Knobs, split, special.

- 272,069 2-13-83 Insulator for electric conductors, T Mack, Plainfield, NJ (Hopelessly impractical.)
 418,369 12-31-89 Screw-cleat for electric wires, G E Huff, Hartford, Conn.
 464,770 12-8-91 Clamp for elec'c wires, J Green & others, Elizabeth, NJ (Adjustable, camming type, one or two elements.)
 525,001 8-28-94 Insulator, L W Bradley, Cincinnati, Ohio (Conductor groove bends around nail.) (Rediculous!)
 526,472 9-25-94 Insulator for elec'c conductors, G A Webster, Phila, Pa., assr 1/2 to others. (Washer is also insulating.)



1,139,748



1,177,996

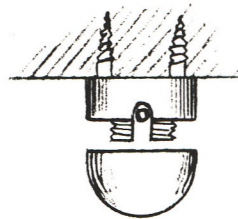

418,369

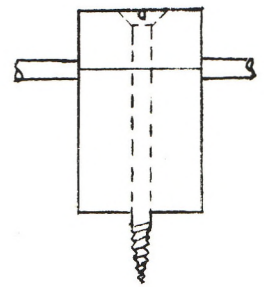

525,001



1,144,153

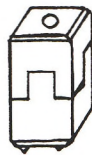

1,201,325

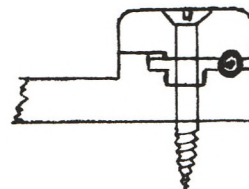

464,770



1,147,498



272,069

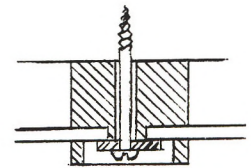
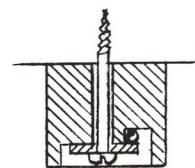
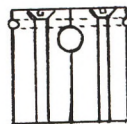

526,472

CLASS 8 (continued)

- | | | |
|-----------|----------|---|
| 745,999 | 12-8-03 | Insulator, S Bower, NY City, assr $\frac{1}{2}$ to J Levy, same. |
| 815,471 | 3-20-06 | Insulator, G L Ricks, Yuma, Ariz. (Convex base, convex cap, cutaways for 2 upward projections.) |
| 840,336 | 12-25-06 | Insulator, A Johnson, Quincy, Ill. (Central block has grooves for different wire sizes.) |
| 855,208 | 5-28-07 | Insulator, H Sinclair, Trenton, NJ |
| 906,296 | 12-8-08 | Insulator, C Rosenberg & V Bailey, NY City (!) |
| 964,586 | 7-19-10 | Insulator, J Tufts, Jr., Weymouth, Mass, assignor $\frac{1}{2}$ to F W Clark, Boston, Mass. |
| 965,723 | 7-26-10 | Insulator, J F Malthaner, Chillicothe, Md. (sic.) (Two-piece, known as "Paragon Knob".) |
| 1,060,886 | 5-6-13 | Insulator, J E Bicknell, Findlay, Ohio, assr to Findlay Electric Porcelain Co., same. (Identical pieces stack to accomodate any number of conductors) |
| 1,194,747 | 8-15-16 | Insulator, H R Kells, NY City. (Both upper and lower pieces provided with a petticoat as shown.) |

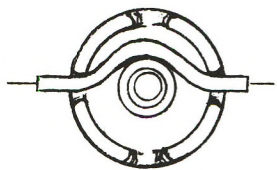

745,999

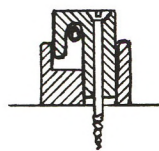

855,208



965,723

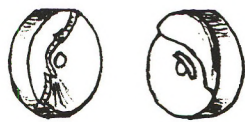
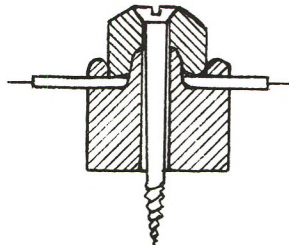

815,471

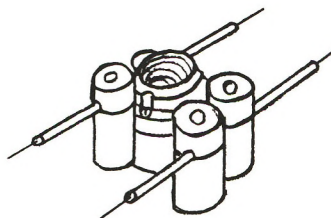

906,296

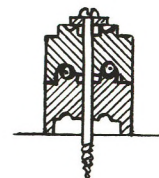

1,060,886

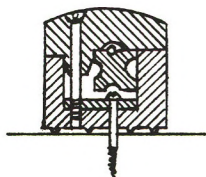

840,336

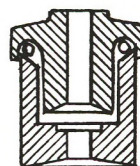

964,586

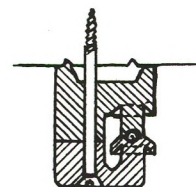

1,194,747

CLASS 10 -- Knobs & Cleats, self-tying.

- | | | |
|---------|----------|--|
| 403,727 | 5-21-89 | Insulator, J C Berrang, Asbury Park, NJ (Plate retaining arms held between the porcelain blocks.) |
| 469,940 | 3-1-92 | Insulator, C N Hammond, Boston (Curved wire entrance slot leads into straight recess for wire.) |
| 479,134 | 7-19-92 | Insulator, C E Conover, Cincinnati |
| 480,011 | 8-2-92 | Insulator, J J Green, Boonton, NJ, assr to Security Insulator Co of NJ. (Twist-lock type, and possible detents to slightly bend wire at final position.) |
| 483,771 | 10-4-92 | Insulator, A P Seymour, Syracuse, NY |
| 511,611 | 12-26-93 | Insulator, C N Hammond, Boston, assignor to Hammond Cleat & Insulator Co, Boston (Three-wire type.) |
| 511,612 | 12-26-93 | Insulator, C N Hammond, Boston (Two-wire type.) |
| 518,214 | 4-17-94 | Ceiling-cleat, H P Ball, Bridgeport, Conn. |
| 520,412 | 5-29-94 | Insulator, C E Conover, Cincinnati, Ohio (Entrance & exit nonparallel planes, thus kinking wire.) |

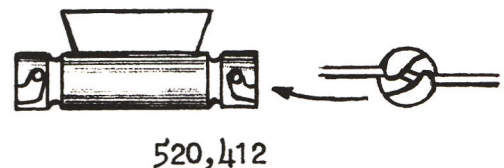
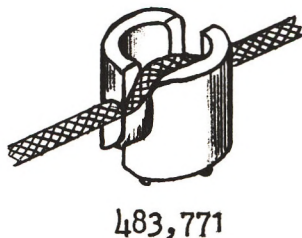
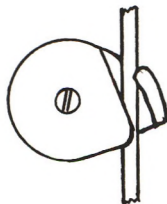
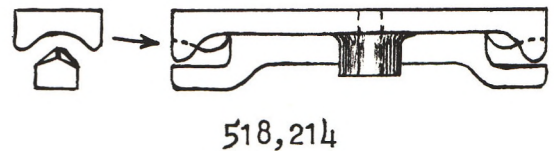
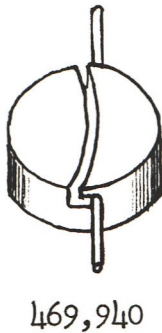
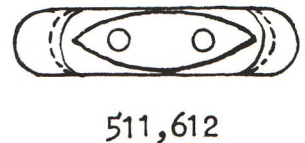
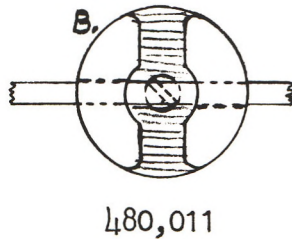
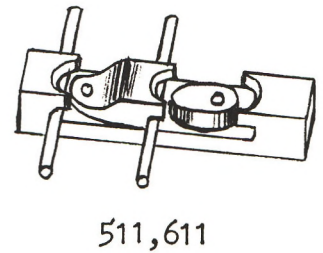
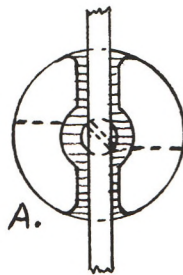
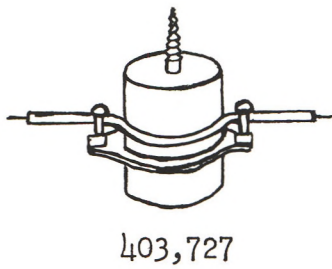

CLASS 10 (continued)

- 522,302 7-3-94 Self-locking cleat for electrical wires, E Nashold Chicago, assignor 2/5 to H W Baskette, Chicago
- 536,684 4-2-95 Self-locking cleat for electric wires, F O Greager, Marseilles, Ill. (Movable dogs hold wire taut.)
- 545,620 9-3-95 Cleat for electric wires, M M Wood, Chicago (Wire slightly bent in final position.)
- 591,104 10-5-97 Insulator for electric wires, W Roberts, Mobile, Ala (Twist-lock. Seated wire prevents insul unscrewing)
- 593,689 11-16-97 Insulator, L F Rembe, Haverstaw, NY
- 621,661 3-21-99 Insulator, Morton Harloe & W S Bloes, Peckville, NY (Three-finger type plus tie wire. Insulator can rotate about the mounting stud.)
- 627,366 6-20-99 Insulator for fastening electric wires, J Treleaven, Vancouver, BC, assr to Painter & Turton, same place.
- 660,271 10-23-00 Insulator-knob for electric-light wiring, R H & J G Henderson, Chicago (Turn of wire around ordinary groove locks in end of wire under the hook part.)

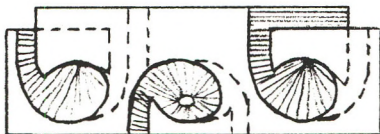

522,302

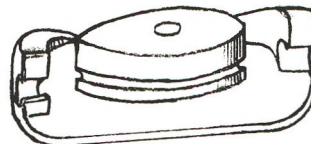

593,689

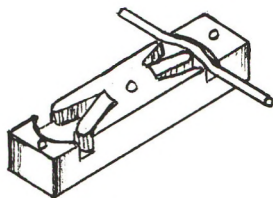

536,684

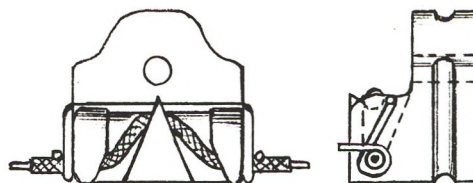

621,661

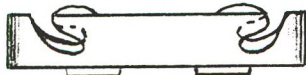

545,620

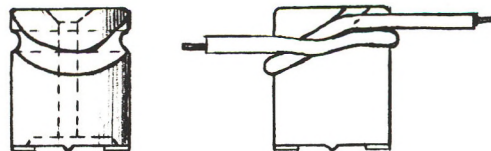

627,366

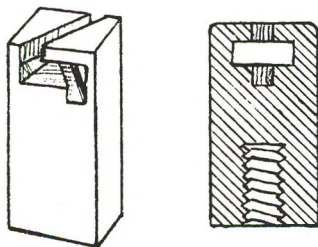

591,104

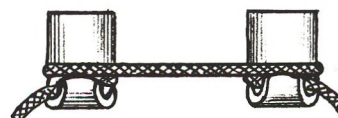

660,271

CLASS 10 (continued)

724,329	3-31-03	Insulator, R H Polk, Birmingham, Ala.
756,724	4-5-04	Insulator, J C Snodgrass, Steubenville, Ohio
757,765	4-19-04	Insulator, J W Osborne, Winchester, Ill. (Pins, plate & screw all coated with insulating material.)
783,348	2-21-05	Insulator, E C Wright, Portland, Ore., assignor $\frac{1}{2}$ to F J McHenry, same place.
785,561	3-21-05	Wiring-cleat, J M Latimer, Weehawken, NJ, assignor to Consolidated Fire Alarm Co., NY City
804,115	11-7-05	Electric insulator, G W Goodridge, Bridgeport, Conn. (Spiral groove, triangular body section at groove.)
815,506	3-20-06	Insulator, H S Blynt, Steubenville, Ohio (Groove at lower end of tapered recess for insertion of wire.)
861,275	6-30-07	Insulator for electric wires, C Gallagher, Richmond, Va. (Arc-shaped groove, bending wire.)
874,445	12-24-07	Insulator, A L Shears, Seattle, Wash. (Upward ears & lateral pegs taper to captivate slightly bent wire.)
887,520	5-12-08	Insulator, J W Rehling, Allegheny, Pa.

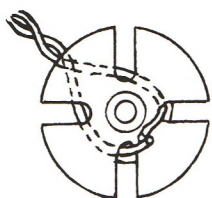

724,329

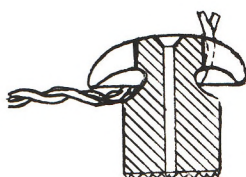

756,724

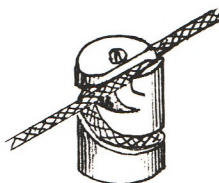

783,348

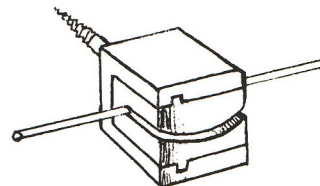

861,275

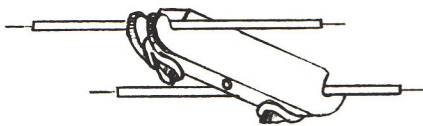

785,561

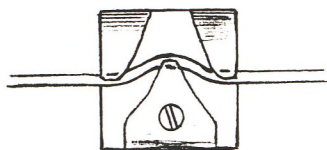

804,115

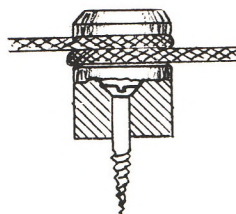

815,506

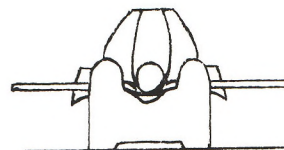

874,445

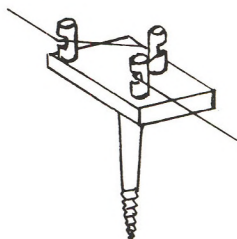

757,765

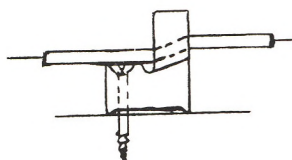

887,520

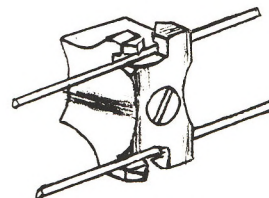

CLASS 10 (continued)

897,669	9-1-08	Insulator, F J Seigwart, Pittsburg, Pa.
970,078	9-13-10	Insulator, J A Meurling, Chicago, Ill.
1,008,087	11-7-11	Insulator, J M Sweeney, Howell, Fla.
1,029,980	6-18-12	Insulator, J Ellis, Salem, Mo., (Reissue #13,748, June 16, 1914, Vol. 203, page 878.)
D. 44,117	5-27-13	Wiring-cleat, C H Waterman, Athens, Mich. (3½ yrs)
1,188,599	6-27-16	Self-tying insulator, S L Youmans & J A McLaughlin, Jesup, Georgia (Wire clip retainer rotates.)
1,640,815	8-30-27	Insulator, H D Brookman, East Liverpool, Ohio
1,718,259	6-25-29	Insulator, A C Scott, Dallas, & W G Rupe, Cameron, Texas (Metal base grips flanged porcelain block, detent retaining porcelain after sliding into place.)
1,954,952	4-10-34	Wire support, E L Klingel, St Paul, Minn.
D.108,489	2-15-38	Electric insulator, R E Dalton, Fostoria, Ohio, assr to Porcelain Products, Inc., Findlay, Ohio (14 yrs)



897,669



D. 44,117

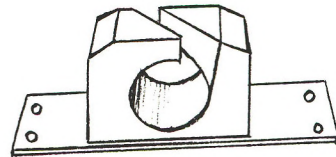

1,718,259

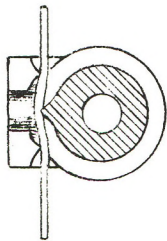

970,078

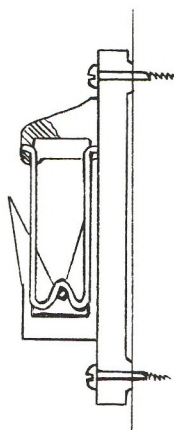

1,188,599

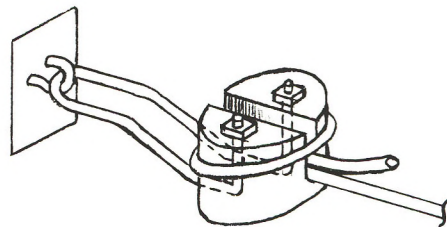

1,954,952

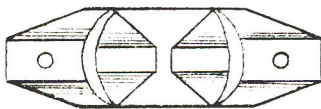

1,008,087

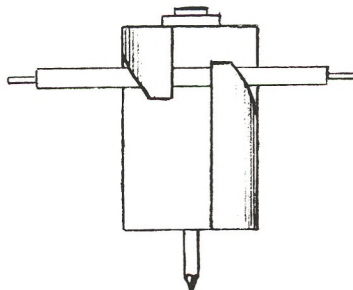

1,640,815

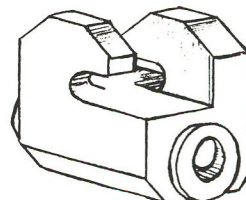

D. 108,489

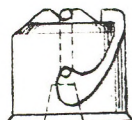

1,029,980

CLASS 10 (continued)

- 2,304,204 12-8-42 Electrical insulator, B B Ratzman, Buttzville, NJ
 2,307,277 1-5-43 Wire support, E L Klingel, St Paul, Minn.
 (Sold under the tradename "Parallel Knob".)

CLASS 12 -- Crossovers.

- 328,728 10-20-85 Insulator, L O Smith, Philadelphia, Pa.
 524,850 8-21-94 Insulator, C N Hammond, Boston, Mass.
 550,673 12-3-95 Cross-over insulator, F G Beron, Waterbury, Conn.,
 assr $\frac{1}{2}$ to J F Gaffney, same place. (Arrangement of
 slots prevents turning when wires are tightened.)
 824,055 6-19-06 Insulator, H M Acly, Pittsfield, Mass., assignor to
 Stanley Electric Mfg Co., same place.
 878,949 2-11-08 Electric-wire insulator, J H Hanson, Chicago, Ill.
 995,838 6-20-11 Knob for electric wiring, F B Bower, Pen Yan, NY,
 assr $\frac{1}{2}$ to E R Ramsey, same. (Two reversible parts
 slide up & down to accomodate different wire sizes.)
 996,782 7-4-11 Insulator, W Moore, Princeton, Ill. (Curved grooves
 outside for conductors, tie wire passing through
 holes in block parallel to respective conductors.)

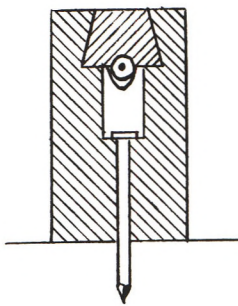

2,304,204

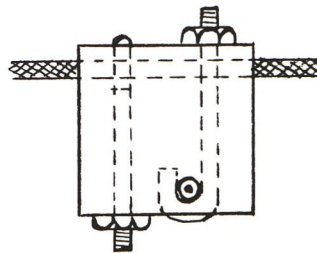

524,850

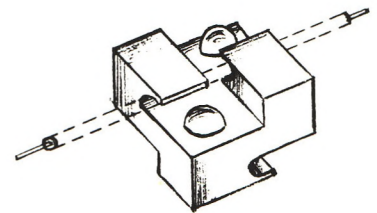

878,949

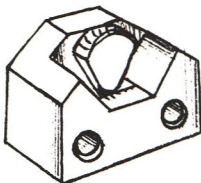

2,307,277

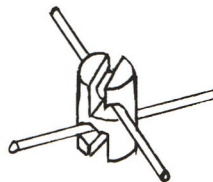

550,673

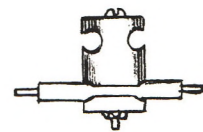

995,838

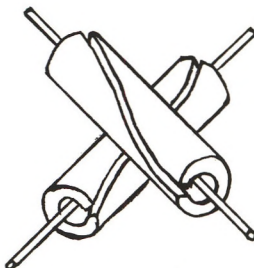

328,728

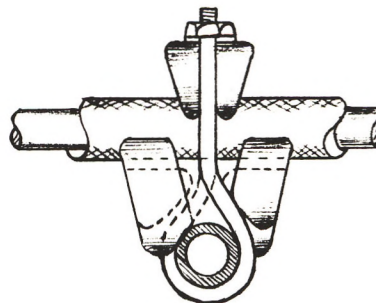

824,055

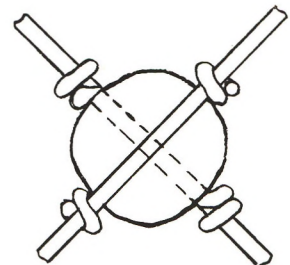

996,782

CLASS 12 (continued)

- 1,056,711 3-18-13 Crossover-insulator for electrical conductors, F Schaub, Jersey City, NJ
 1,176,801 3-28-16 Insulator, W H Williams, Carey, Ohio (Reissued #14,256, Feb 16, 1917.)
 1,755,587 4-22-30 Insulating device, W Broad, Beaver Falls, Pa., assr 3/4 to H E McLain, Pittsburgh, Pa. (Wire passing through both porcelain parts retains the assembly.)

CLASS 14 -- Knobs using tie wires.

- 349,788 9-23-86 Insulator, N T Finch, Chicago (Screw is embedded.)
 450,384 4-14-91 Elec'c-wire insulator, D Bertolette, Norristown, Pa.
 477,980 6-28-92 Insulator, H C Wirt, Boston, assr to Thomson-Houston Electric Co., Conn. (Tie wires not required.)
 482,913 9-20-92 Insulator, H H Brooks, Cambridge, Mass., assr 1/2 to A T Clark, Boston (Sheet metal bracket holds porc.)
 549,443 11-5-95 Electric supporting-insulator, J Collins, Washington, D.C. (Square knob.)
 669,761 5-13-02 Insulator, H F Kretzer, St Louis, Mo. (Lightning rod ground insulator.) (Not illustrated below.)

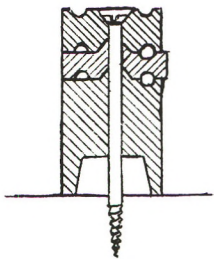

1,056,711

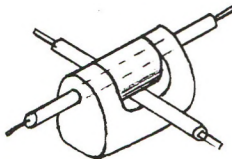

1,755,587

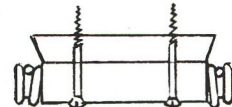

477,980

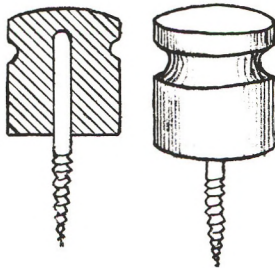

349,788

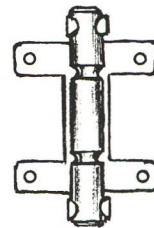

482,913

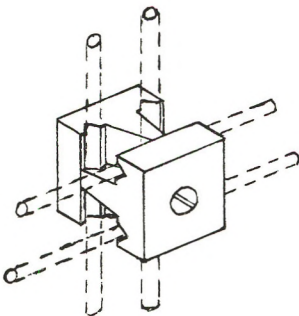

1,176,801

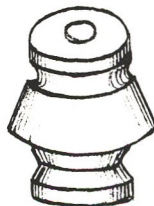

450,384

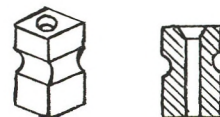

549,443

CLASS 14 (continued)

753,399	3-1-04	Combination bracket & knob for electric conductors, E C Hunt, Belle Plaine, Ia., assr $\frac{1}{2}$ to C W E Snyder
868,530	10-15-07	Telegraph and telephone insulator, J A Cooper, Mercury, Texas
879,033	2-11-08	Insulator for electric wires, J Caldwell, Phila, Pa. (Round knob with base of groove triangular shape.)
948,321	2-8-10	Knob-insulator, S P Grace, Pittsburgh, Pa., assr to Western Electric Co., Chicago (For twisted pairs, groove rib separating tie wire from pair.)
954,596	4-12-10	Insulator, A L Stadermann, Terre Haute, Ind. (Sold under the tradename "Universal Knob".)
1,186,862	6-13-16	Insulator, O P Swartz, Mt Pleasant, Pa. (Grooves in outer & inner pieces align, retained by tie wire.)
1,527,318	2-24-25	Insulator, E Lewis, NY City, assr to A T & T Co, NY
1,530,298	3-17-25	Knob, Y C Chambless & A L Lee, Panama City, Fla.
1,736,043	11-19-29	Insulator, W D Kyle, assignor to Line Material Co. (Recessed hex opening for bolt head, tool-engaging knob surface. Turn whole insulator to seat screw.)

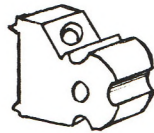

753,399



948,321

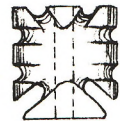

1,527,318

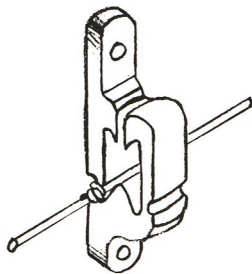

868,530

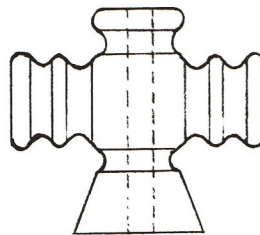

954,596

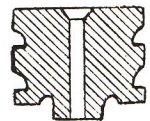

1,530,298

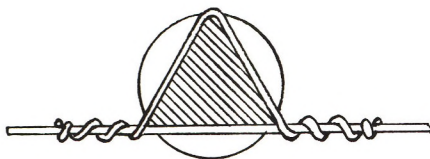

879,033



1,186,862

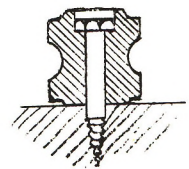

1,736,043

CLASS 14 (continued)

- | | | |
|-----------|---------|--|
| 1,755,971 | 4-22-30 | Insulator, R Smalley, Arlington, NJ, assr to Claude Neon Lights, Inc, NY City (Neon sign standoff.) |
| D.115,530 | 7-4-39 | Insulator, L A Stohl, Sun Prairie, Wis. (7 years) |
| D.121,705 | 7-30-40 | Electric fence knob, R R Smith, Lakewood, O. (14 yr) |
| D.126,721 | 4-22-41 | Strain insulator, L J Schilling, Brookfield, Ill., assignor to Babson Brothers, Chicago, Ill. (14 yrs) |
| D.126,722 | 4-22-41 | Line insulator, ditto above inventor (14 years) |
| 2,311,779 | 2-23-43 | Insulating apparatus for electric fences, L J Schilling, assignor to Babson Brothers, Chicago |
| 2,343,576 | 3-7-44 | Support for electric conductors, R R Pittman, Pine Bluff, Ark. |
| 2,688,654 | 9-7-54 | Insulator for fence posts, A Bussman, St Louis, Mo. |

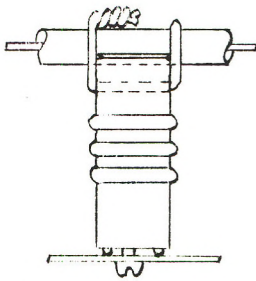

1,755,971

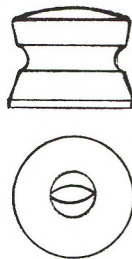

D. 126,721

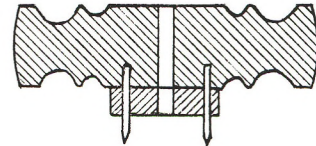

2,343,576

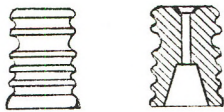

D. 115,530

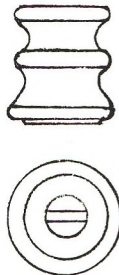

D. 126,722

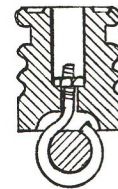

2,688,654

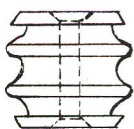

D. 121,705

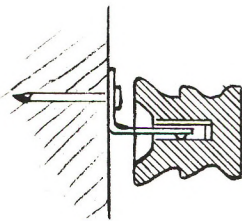

2,311,779

CLASS 15 -- Wireholders and similar.

D. 52,991	2-11-19	Insulator, J T Horton, Brooklyn, NY (14 years)
D. 53,522	7-8-19	Insulator, C L Peirce, Jr., Pittsburgh, Pa, assr 1/2 to Hubbard & Co., Pa. (14 years)
1,594,207	7-27-26	Insulator, W D Kyle, Milwauk., assr to Line Material Co., So. Milwaukee (Polygonal sides, for wrench.)
1,651,704	12-6-27	Line insulator, L E Hendee, Milwaukee, assr to L-M
1,664,172	3-27-28	Insulator, J R Holler, Ellwood City, Pa.
1,720,181	7-9-29	Insulator, W D Kyle, Milwaukee, assr to L-M Co.
1,779,501	10-28-30	Insulator, A G Steinmayer, assr to Line Material Co.
2,155,189	4-18-39	Electric wire bracket, W A Heinrich, assr to James R. Kearney Corp., St Louis, Mo.
2,228,196	1-7-41	Insulator, O A Boch, E Liverpool, Ohio (Insert to close outward recess after screw is installed.)

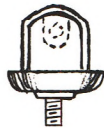

D. 52,991



1,651,704



1,779,501



D. 53,522

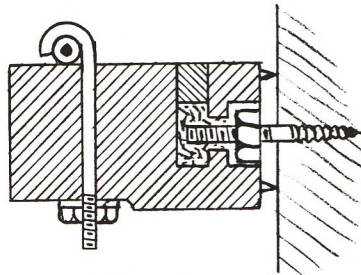

1,664,172

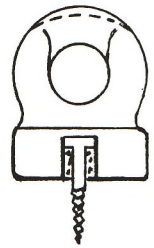

2,155,189



1,594,207

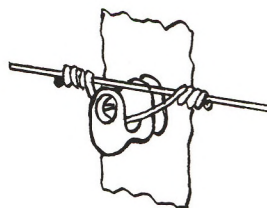

1,720,181

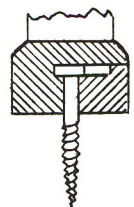

2,228,196

CLASS 16 -- Insulator blocks held in clamps.

368,284	8-16-87	Electric-wire-clamp insulator, J R Fletcher, Dayton
369,447	9-6-87	Insulator, E T Greenfield, NY City (Wire into slot, plug inserted, then block rotated to retain plug.)
419,642	1-21-90	Insulator for electric wires, I P Cornog, Phila, Pa.
466,726	1-5-92	Insulator, G B Nograve, Phila, Pa. assignor to R L Brewster, NY City (Metal yoke, porcelain blocks.)
477,753	6-28-92	Insulator, F D'a Goold, NY City, assignor to Edison General Electric Co., NY (Spring wire hanger.)
491,362	2-7-93	Insulator, A R Lane, NY City
495,552	4-18-93	Insulator, L Hills, NY City (McLeod Ward & Co item)
503,778	8-22-93	Insulator for elec'c wires, W D Trimble, Hanesville, Md. (Porcelain half-pieces held in brackets with a central mounting pin.) (Not illustrated below.)
554,723	2-18-96	Insulator, E Peboulet, Alexander, Ark.
554,955	2-18-96	Insulator for electric wires, M Riera, Havana, Cuba (Two L-shaped pieces, elastic filler gripping wire.)

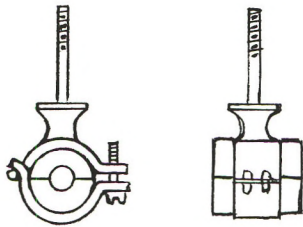

368,284



466,726



495,552

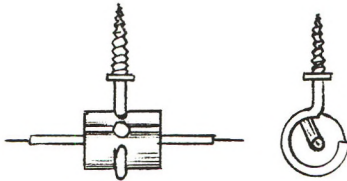

369,447

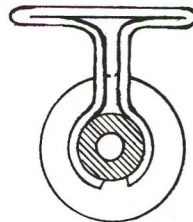

477,753

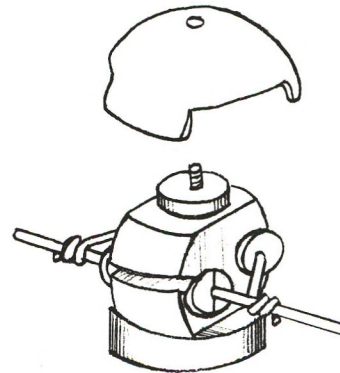

554,723

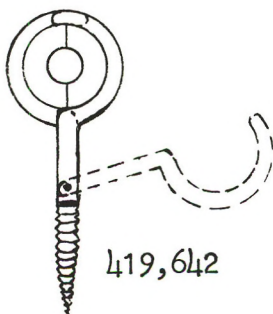

419,642



491,362

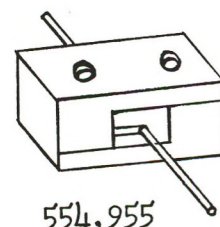

554,955

CLASS 16 (continued)

583,692	6-1-97	Insulator, E Renault, Waldo, Fla.
584,235	6-8-97	Insulator for telegraph or other electric wires, C C Nesmith & G F Arnett, Manchester, Ala.
660,140	10-23-00	Insulator, C Alley, Pendleton, Ind., assignor 1/3 to C H Miller & H Wagner, Anderson, Ind.
751,739	2-9-04	Insulator, P S Lindal, Edinburg, Pa.
756,627	4-5-04	Insulator, J A Hanson & A F Lambert, Davenport, Wash.
787,107	4-11-05	Telegraph or telephone wire insulator, R J McDaniel & S V Graves, assignors to S I Hudson, Watkins, Mo.
803,973	11-7-05	Insulator, G M Bemis, Readsboro, Vermont
826,916	7-24-06	Insulator, S Bartley & W O Bartley, Calhoun, Ill. (Locking plate over beveled & toothed surfaces.)
830,585	9-11-06	Insulator for telegraph & telephone wires, S Graves & H McDaniel, McFall, Mo. (Bend tabs to hold cover.)

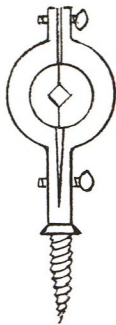

583,692

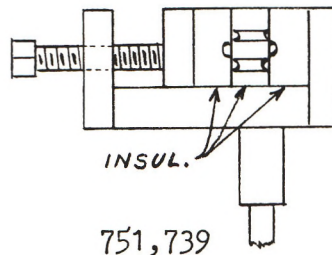

751,739

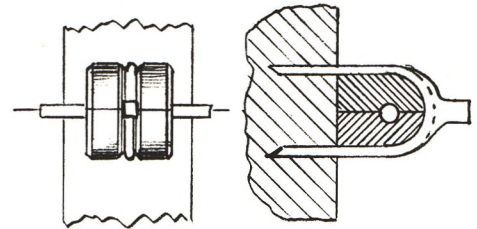

756,627

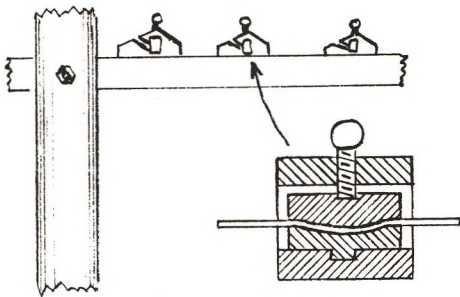

584,235

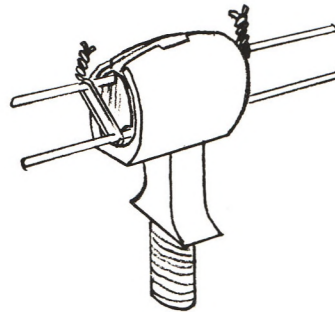

787,107

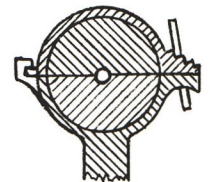

826,916

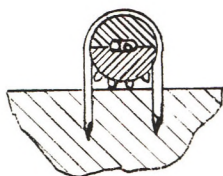

660,140

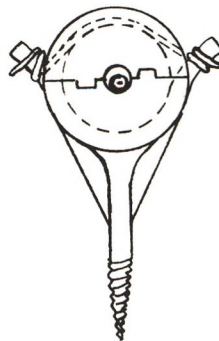

803,973

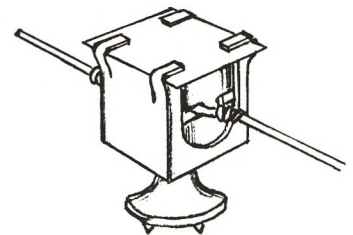

830,585

CLASS 16 (continued)

- 834,533 10-30-06 Insulator, J F Nichols, Plainfield, Ark., assignor $\frac{1}{2}$ to C D Stevens, Magnolia, Ark.
- 854,315 5-21-07 Insulator, H D Stauffer, Oregon, Ill.
- 888,154 5-19-08 Insulator, H Friend, Lexington, Okla., assignor $\frac{1}{2}$ to W J Stevens, same place.
- 915,406 3-16-09 Insulator, S Bartley & W O Bartley, Calhoun, Ill.
(Top insulator half overhangs wire to protect same.)
- 918,905 4-20-09 Insulator, B A Pond, Boston, Mass.
- 947,094 1-18-10 Insulator, E Burton, Ansley, Nebr.
- 971,619 10-4-10 Insulator, J T Klugh, Madison, Mo.
- 996,312 6-27-11 Insulator, T Childress, Anstead, W Va, (Cap smaller than base, clamped down by flattened U-bolt top.)
- 999,683 8-1-11 Insulator, A B Tinsley, Anstead, W Va

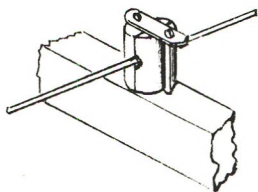

834,533

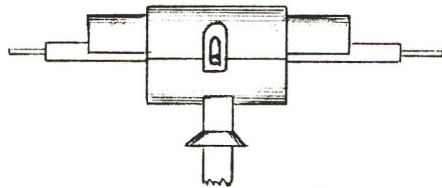

915,406

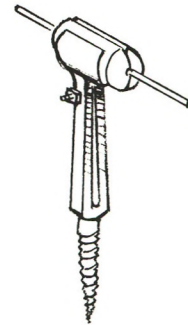

971,619

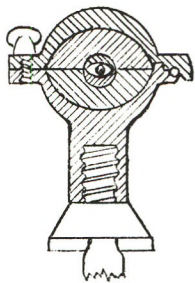

854,315

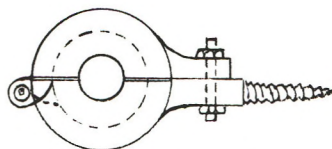

918,905

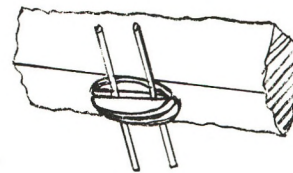

996,312

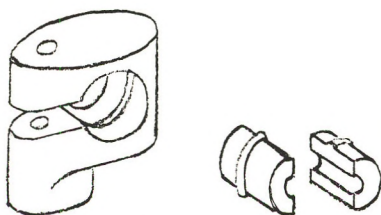

888,154

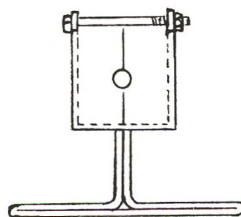

947,094

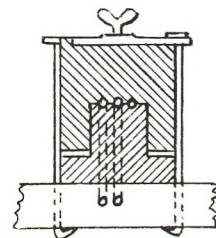

999,683

CLASS 16 (continued)

- | | | |
|-----------|----------|--|
| 1,011,164 | 12-12-11 | Insulator, S C Cornelius, McDowell, Mo. |
| 1,027,601 | 5-28-12 | Insulator & support, L F Gressett, Ballinger, Texas
(Nonreversible. Bends wire, clamp holds together.) |
| 1,047,059 | 12-10-12 | Insulator-support for line-wires, Hoybrook, Tyler, TX |
| 1,070,151 | 8-12-13 | Insulator, W H Martin, Ukiah, Cal., assr ½ each to
D Newman, Ukiah and M P Knupp, Yountsville, Cal. |
| 1,071,419 | 8-26-13 | Insulator, B Hetherington, Everest, Kans. |
| 1,212,547 | 1-16-17 | Automatic insulator, R A Parent, So. Tacoma, Wash. |
| 1,233,475 | 7-17-17 | Insulator, C C Hudson, Niceville, Fla. |
| 1,788,245 | 1-6-31 | Insulator sup't, R Manson, Ptsbg, assr Hubbard & Co. |
| 1,956,526 | 4-24-34 | Insulated support for electric wires, J I Ellmann,
assr to Ellmann, Inc, Washington, DC (Cable hanger.) |

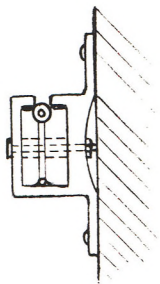

1,011,164

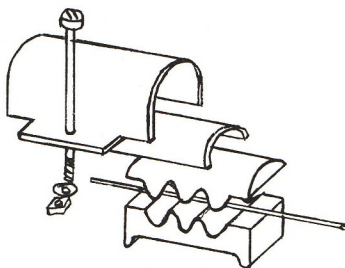

1,070,151

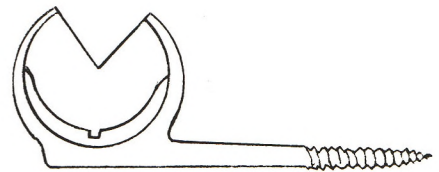

1,233,475

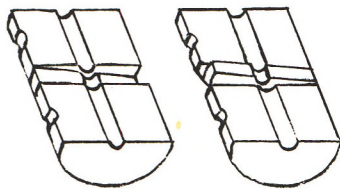

1,027,601

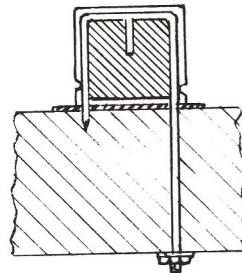

1,071,419

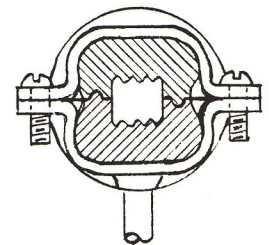

1,788,245

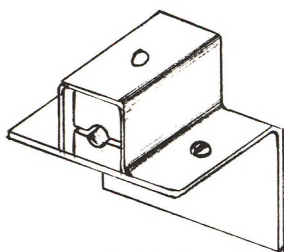

1,047,059

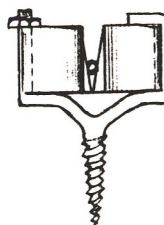

1,212,547

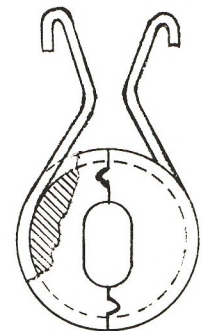

1,956,526

CLASS 18 -- Clamp types & rack insulators.

678,042	7-9-01	Rack-insulator, H R Sargent, Schenectady, NY, assignor to General Electric Co., New York
770,278	9-20-04	Insulation-rack, J R Fletcher, Dayton, Ohio
1,013,241	1-2-12	Insulator, F VanEtten, Davenport, Iowa (3 sections.)
1,125,742	1-19-15	Cable-supporting insulator, E O Sessions, Chicago, assr to Electrical Engineers Equipment Co, Chicago
1,240,330	9-18-17	Insulator & support therefor, L Fort, Jersey City, NJ
1,625,645	4-19-27	Insulator, L Fort, Jersey City, NJ
1,920,978	8-8-33	Insulator, L Fort, Jersey City, NJ

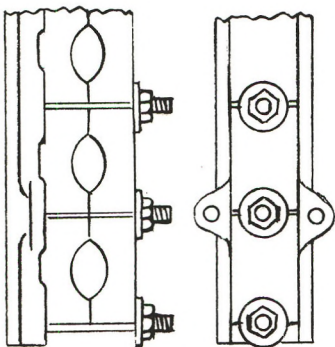

678,042

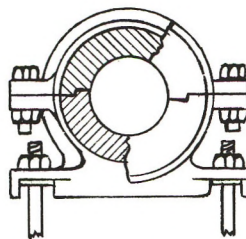

1,125,742

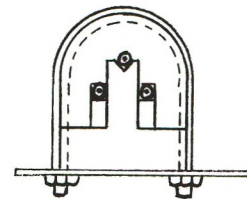

1,625,645



770,278

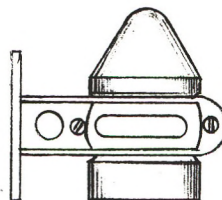

1,240,330

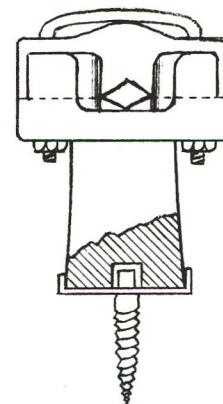

1,920,978

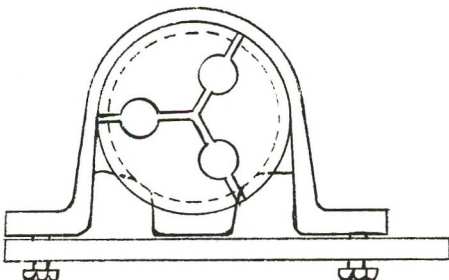

1,013,241

CLASS 20 -- Slack-wire knobs and spikes.

- | | | |
|-----------|----------|---|
| 306,718 | 10-21-84 | Insulator, E Clark, Jersey City, NJ |
| 306,719 | 10-21-84 | Insulator, E Clark, Jersey City (Metal hooks run through or screwed into wooden blocks.) |
| 573,101 | 12-15-96 | Wall insulator, J J O'Neill, Boston, Mass. |
| D. 31,861 | 11-21-99 | Ring insulator, H P Copeland, Jersey City (3½ years) |
| 667,103 | 1-29-01 | Insulator, H R Sargent, Schenectady, NY, assignor to General Electric Co, New York (Elastic loop up into knob. Top hook secures. Notch is for disassembly.) |
| 679,308 | 7-30-01 | Insulator, H Geisenhoner, assr to G.E. Co., New York |
| 907,834 | 12-29-08 | Insulator, G B Marshall, Shannon, Texas |
| 1,596,931 | 8-24-26 | Insulator, B P Joyce, Davenport, Ia. (Spool in resilient strip which grasps picture molding.) |

CLASS 22 -- (Please see page 156.)

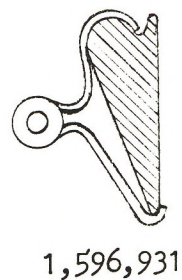
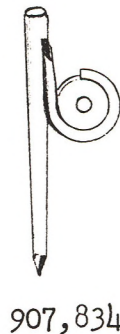
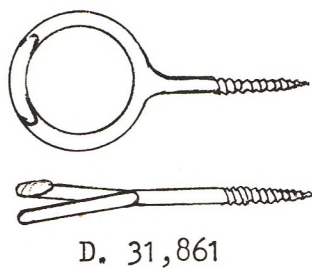
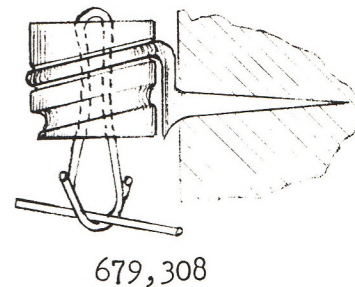
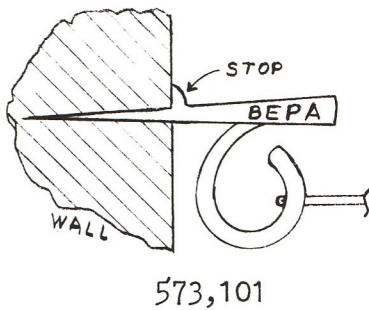
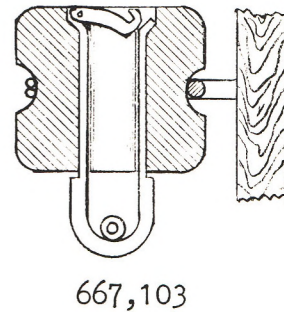
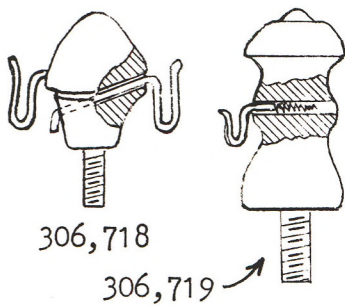

CLASS 24 -- Swinging tree types and hangers.

- | | | |
|-----------|----------|--|
| 444,879 | 1-20-91 | Insulator, C Elkins, Saccarappa, Maine |
| 626,065 | 5-30-99 | Insulator, W E Holmes, Newton, Mass. (Uses pin type) |
| 756,026 | 3-29-04 | Insulator, W S Kingsley & S S Bell, Reading, Mass. |
| 802,096 | 10-17-05 | Tree-insulator, C W Dunton, Boston, assignor 1/2 to F D Field, Cambridge, Mass. |
| 887,578 | 5-12-08 | Hanger for electric wires, D Beyer, Edgewood Pk, Pa. |
| 973,409 | 10-18-10 | Insulated hanger, E Crabbe, Seattle, Wash. |
| 1,176,629 | 3-21-16 | Tree-insulator & wire-supporter, W Wallace, Roscommon, Mich. (Porc. tube in metal bracket, rotatable.) |
| 1,258,802 | 3-12-18 | Insulator-support, A J Morgan, Framingham, Mass. |
| 1,282,876 | 10-29-18 | Line-conductor support, W D Kyle, Milwaukee, Wis. |
| 1,882,486 | 10-11-32 | Insulator, W H Cole, Abington, Mass. (Two sister hooks enclose cable, secured with bottom tie wire.) |

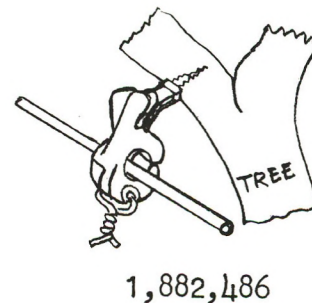
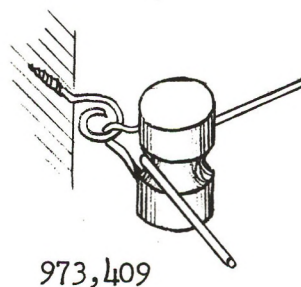
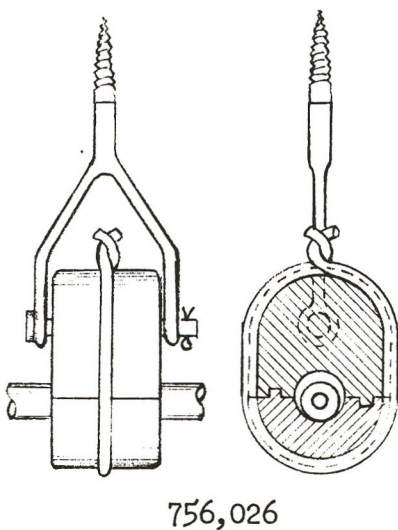
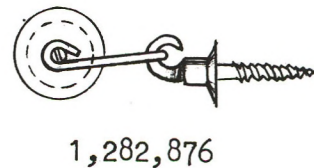
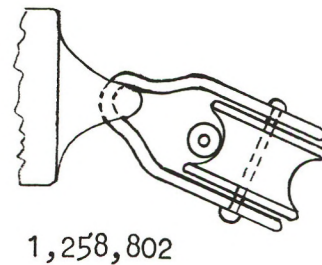
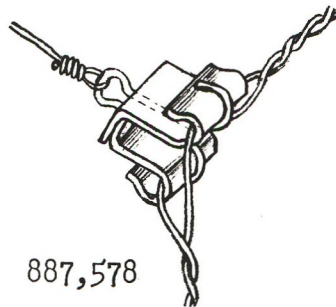
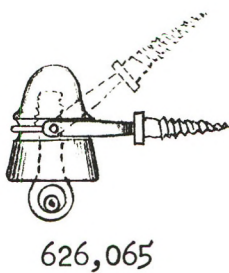
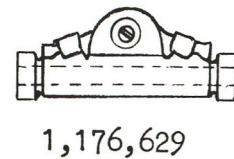
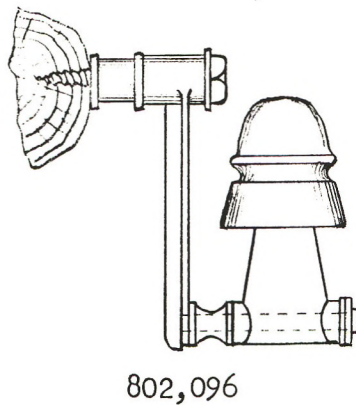
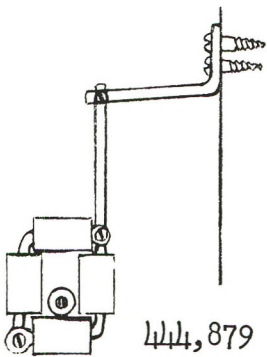

CLASS 25 -- Miscellaneous tree insulators.

- | | | |
|-----------|----------|--|
| 346,475 | 8-3-86 | Insulator-block for electric conductors, T Hawken, Salem, Mass. |
| 403,491 | 5-14-89 | Insulating device for line-wires, T Smith, Brooklyn, NY, assignor to E S Greeley & Co., Connecticut |
| 758,175 | 4-26-04 | Insulator, S C Cutter, Oswego, Ill. |
| 951,505 | 3-8-10 | Insulating-tube, T T Mather, Egg Harbor City, NJ (Split tube, registry pins, 3 tie-wire grooves.) |
| 1,595,653 | 8-10-26 | Tree insulator, Gammon & Averill, Haverhill, Mass. assrs $\frac{1}{2}$ to Line Material Co, So Milwaukee, Wis. |
| 1,620,804 | 3-15-27 | Insulator, S C Cutter, Oswego, Ill. |
| 1,721,657 | 7-23-29 | Insulator, S C Cutter, Oswego, Ill. |
| 2,361,109 | 10-24-44 | Insulating protector for conducting wires, M M Kennally, assr to Porcelain Insulator Corp., Lima, NY |



346,475

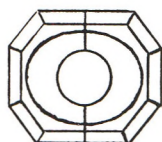

403,491

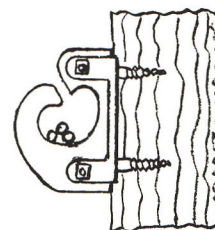

1,620,804

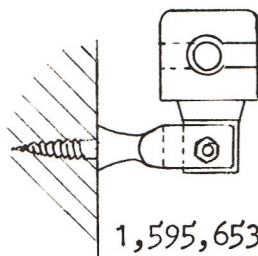

1,595,653

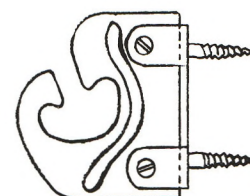

1,721,657



758,175



951,505

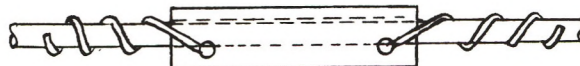

2,361,109

CLASS 26 -- Mine insulators & their pins.

- | | | |
|-----------|----------|---|
| 526,498 | 9-25-94 | Conductor-support & insulator, D N Osyor, Columbus, Ohio, assr to Joseph A Jeffrey, same place. |
| 667,882 | 2-12-01 | Feeder-wire insulator, C K King, Mansfield, Ohio (Washer-pin retainer system. Grooves thru insulator allow moisture drainage without wetting wire groove) |
| 696,665 | 4-1-02 | Wire-insulator, W C Benbow, Columbus, Ohio, assignor to Benbow Company, Columbus |
| 903,692 | 11-10-08 | Feeder-wire insulator, G M Finskel, Columbus, Ohio, assr to The Sackett Mine Supply Co., Ohio (Uses key-shaped pin, camming surface to tighten.) |
| 971,322 | 9-27-10 | Mine-insulator, C W Speakman, Monongahela, Pa. (Pin grooved, concave insulator top, to drain moisture. Lugs on pin through keyway retain insulator.) |
| 1,013,250 | 1-2-12 | Insulator-pin, W J Wilson, Pittsburg, Pa. (Stamped sheet metal, folded over, deforms to fit hole.) |
| 1,213,002 | 1-16-17 | Insulator, F C Pierce, Campbird, Colo. (Side entry to vertical wire slot, wedges to retain conductor.) |

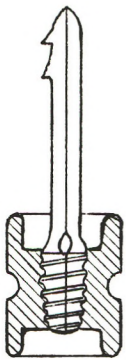

526,498

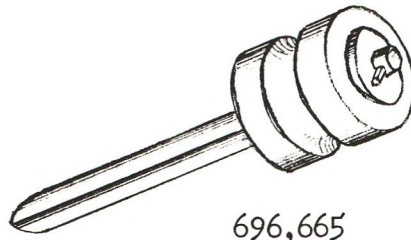

696,665

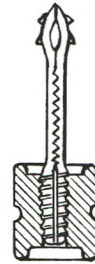

1,013,250

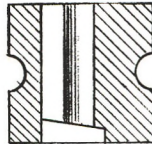

903,692

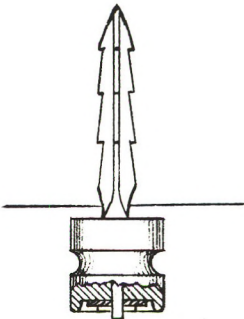

667,882

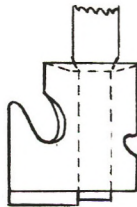

971,322

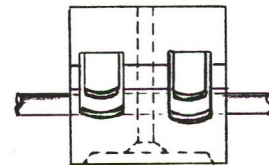

1,213,002

CLASS 35 -- Wall tubes.

- | | | |
|-----------|----------|---|
| 476,964 | 6-14-92 | Insulating-tube for elec'c conductors, A P Seymour, Syracuse, NY (End projections secure in place.) |
| 517,591 | 4-3-94 | Insulator-tube, M Robinson, Newton, Mass. (4 spline ridges provide air space between wood and tube.) |
| 607,315 | 7-12-98 | Insulator, C L Wingard, Walla Walla, Wash., asssr ½ to L H Wingard. (Installable after wire is in place.) |
| 773,733 | 11-1-04 | Insulator, L W Greene, Brooklyn, NY (Fits varying wall thickness. Retainer clip holds in place.) |
| 1,080,257 | 12-2-13 | Insulator, K Bruchsaler, San Francisco, Cal. (Metal strip attached to head, bent up at end to secure.) |
| 1,158,105 | 10-26-15 | Insulating-tube, E F Callender, Galesburg, Ill., asssr ½ to L B Callender. (Tapered fins secure.) |
| 1,171,267 | 2-8-16 | Insulator for electrically charged wires, G R Smith, Arlington, Md. (Spring clip with gripping teeth.) |
| 1,206,882 | 2-15-16 | Insulating-tube, G T Morene, Nixon, Texas. (Wedge-shaped parts, staggered positions, secure tube.) |

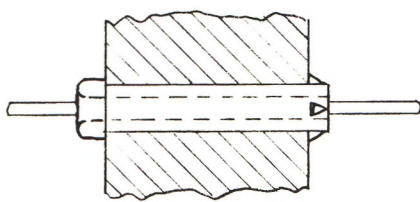

476,964

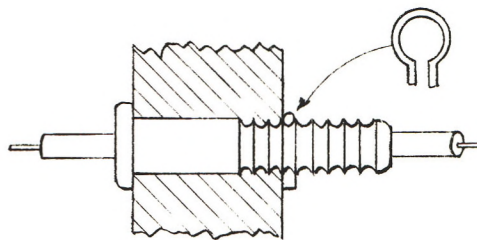

773,733



517,591

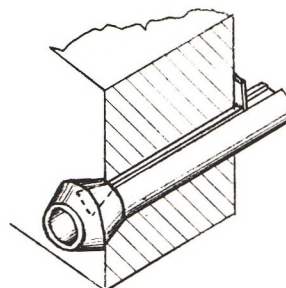

1,080,257

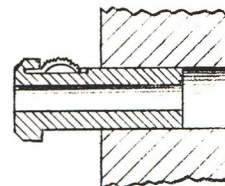

1,171,267

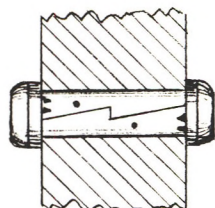

607,315



1,158,105



1,206,882

CLASS 36 -- Bushings for holes & conduits.

- 684,909 10-22-01 Insulating-bushing, J A Cole, Boston. (Pushes into hole in yielding plate and snaps into place.)
 947,185 1-18-10 Insulating-support, G B McBean, Chicago, assignor to Mechanical & Electrical Mfg Co, Chicago
 1,056,392 3-18-13 Insulator, C A Barr & J H Koren, Chicago (Held in place by spring clip engaging grooves on bore.)

CLASS 22 -- Crossarm block types.

- 430,696 6-24-90 Insulator, W H Seamon (Longitudinal grooves for conductor and tie wire.)
 568,060 9-22-96 Insulator, W Wood, Middlebury, Conn., (Double slotted tubes, one end flanged, inserted into crossarm.)
 1,022,026 4-2-12 Insulator, J A Guthrie, Little Rock, Ark., assignor to Guthrie-Mitchell Co., same place.
 1,099,374 6-9-14 Insulator, I Hunter, Carlisle, Kent., assr 2/3 to G C Rafferty & 1/3 to L Wells, both Carlisle, Kent. (Two-piece. Long axial slots align for conductor, rotate to align eccentric end grooves for tie wire.)

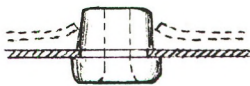

684,909

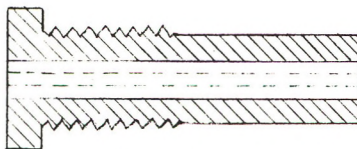

430,696

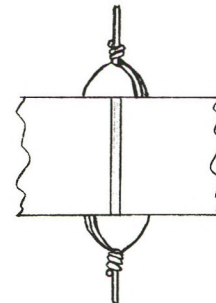

1,099,374

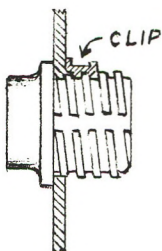

947,185

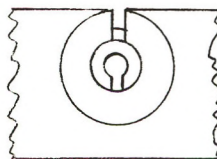

568,060

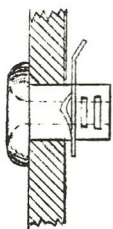

1,056,392

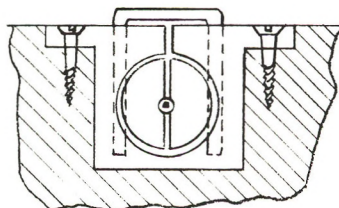

1,022,026

OTHER INSULATOR PATENTS

CLASS 28 -- Strains and break knobs.

352,436	11-9-86	H Winton.	End hooks, embedded fail-safe ring.
352,437	11-9-86	H Winton.	Ramshorn hooks in each end of insulator.
445,790	2-3-91	H Winton.	Ramshorn ends, interlock inside block.
459,686	9-15-91	C Gerrard	
467,941	2-2-92	C Lee ($\frac{1}{4}$ Gould & Watson Co).	Interlocked internally.
474,319	5-3-92	C Goodrich ($\frac{1}{2}$ assnd).	Long, interposed U-bolts.
476,828	6-14-92	A P Seymour.	Standard circuit-break knob.
482,872	9-20-92	C Lee (Johns-Pratt Co.).	(Impractical)
488,046	12-13-92	C Wirt.	Eye bolts attach threaded male-female.
515,779	3-6-94	H Luscomb (Johns-Pratt Co.)	
530,498	12-11-94	H Ball (G.E. Co., Boston).	Pressure-planes type.
650,445	5-29-00	E Zertuche, Pueblo, Mexico.	Z-shaped passages.
1,028,104	6-4-12	O Fletcher (Peru Electric Co.)	
1,039,799	10-1-12	C Priestly, Paris, France.	Similar to "pork liver".
D. 44,118	5-27-13	T White.	Closed-end strain, square. (7 years)
D. 45,172	1-20-14	T White.	" " " , round. (7 years)
D. 46,014	6-30-14	A Austin (O-B Co.).	Crossed planes. (7 years)
D. 46,243	8-11-14	C Bundy.	(14 years)
D. 46,451	9-22-14	W Schaaake (Westinghouse).	Ribbed closed-end. (14 yr)
1,216,000	2-13-17	T Scully.	Water drain holes on ends of closed-end.
D. 52,139	7-2-18	J Kendig.	Ribbed, closed-end break knob. (14 years)
D. 56,262	9-14-20	A Austin (O-B Co.).	Open-end strain.
D. 59,947	12-31-21	A Austin (O-B Co.).	Crossed-plane, closed. (14 yrs)
D. 69,381	2-9-26	L S Brach (Mfg Co).	Standard radio strain. (7 yrs)
1,706,987	3-26-29	O Schaffler.	Skirted ends.
1,707,054	-29		(very similar to 1,706,987)
2,540,608	2-6-51	A Bussman.	For electric fence, open-end strain.

CLASS 32 -- Knob-mounting clips and brackets.

573,966	12-29-96	R Duncan.	Metal clip, rests down on edge of girder.
746,362	12-8-03	McFeaters.	Set-screw bracket for edge of girders.
989,231	4-11-11	W Chamberlain.	Rotatable bracket.
1,271,596	7-9-18	W Mayer (Elec Serv Supplies Co).	Set-screw bracket for girders. Knob adjusts to any angle.
1,315,633	9-9-19	G McFeaters.	Girder mount, holds 4 knobs, any angle.
2,213,425	9-3-40	H Young (Western Wire Prod. Co).	Fastener clip thru regular knob hooks over edge of angle-iron girder.

CLASS 40 -- Miscellaneous non-pintypes.

161,058	3-23-75	G Pidgeon.	Block, positive wire sparation.
254,610	3-7-82	W Capewell.	Hinged blocks hook together about wire.
303,399	8-12-84	G Prince.	Wire thru knob, tie-wire to side notches.
305,020	9-9-84	J Ruth.	Lightning rod insulator, 2-piece, dovetailed.
336,828	2-23-86	C Travis.	Petticoated hanger type.
386,111	7-17-88	H Cutler.	Wire between two knobs mounted on plate.
402,752	5-7-89	F Locke.	Hanger type for crossarms.
413,146	10-15-89	L McCarthy (to Gould & Watson Co).	Knobs enclose.
421,819	2-18-90	J Davy.	Two pieces slide together to grip wire.

CLASS 40 (continued)

450,294	4-14-91	Lieb & Lavens. Metal finger tabs in porcelain.
450,708	4-21-91	T Creighton. Lightning rod holder, screw mounting.
481,624	8-30-92	Pass & Seymour, Inc. Ceiling rosette cut-out.
482,297	9-6-92	W Clark. Crown groove, side tie wire, screws in.
485,106	10-25-92	C Lee (Johns-Pratt Co). Knob, built-up mica sheets.
546,585	9-17-95	Dibb & Vickers. Plug in cavity (NOTI insulator).
570,034	10-27-96	C Martin (G.E. Co.). Third-rail insulator.
574,828	1-5-97	B Smock. Hanger on hook, wedge to retain wire.
588,048	8-10-97	G Ashby, Canada. Spool mounted in fork.
D. 30,564	4-18-99	J Morgan. Screw-mounting type of tube.
664,176	12-18-00	E Risler, Germany. Five-piece knob assembly.
682,709	9-17-01	W Jenkins. Metal-composition combo, side support.
710,282	9-30-02	E Lefever. Plate clips on porc. block hold wire.
736,049	8-11-03	J Wood. Primary fuse cutout (Ft Wayne Elec'c Works)
746,469	12-8-03	B Cullen. Multiple-piece assembly wire hanger.
746,671	12-15-03	T Carter. Swinging toothed dogs on block hold wire.
767,948	8-16-04	F Locke. Skirted thru-pin dead-ending insulator.
795,521	7-25-05	J Lapp. Multipart, skirted thru-pin dead-end.
825,795	7-10-06	M Baker. Pivoting top on stationary base.
849,896	4-9-07	C Griffith. Toothed cam wire retainer, side of knob.
870,187	11-5-07	F Locke. High tension wall insulator.
908,089	12-29-08	J Gibson. Two-piece knob screws onto mounting stud.
918,127	4-13-09	W Clark. Wedge holds conductor into crown groove.
986,213	3-7-11	J Phelps. End outlet bushing, metal clip attached.
1,028,534	6-4-12	C Brady. Knob, hook bolt pulling wire into groove.
1,031,975	7-9-12	F Warren. Porcelain tube tie-wired to metal base.
1,032,545	7-16-12	R Hilty. Two-piece knob, pieces dovetailed together.
1,038,418	9-10-12	W Nelson. Knob type, special tie-wire method.
1,040,971	10-8-12	C Wirt (Elec. Specialty Co). Insulated conduit joint
1,072,999	9-9-13	G Simcoe. (Incomprehensible from the O.G.)
D. 46,862	1-19-15	R Clapper. Special knob. (7 years)
1,169,246	1-25-16	A Folstad. Concave base for pole, conductor hook.
1,175,849	3-14-16	F Warren. Base to mount tube to conduit items.
1,185,700	6-6-16	B Moss. Double-spool mount for break insulator.
1,224,320	5-1-17	J Phelps. Conduit end outlet bushing.
1,268,972	6-11-18	L Hendee. Double spools on wall-mounting bracket.
1,292,451	1-28-19	L Fort. B & D cleat in a line-wire application.
2,286,488	6-16-42	L Johnson (P P Inc). Special shape of rack spool.
2,517,221	8-1-50	R Loux. Multiple service dead-ender spool.
2,921,112	1-12-60	L Dykstra (PINGO). Three-phase strand separator.
2,372,995	4-3-45	P Whitmore. Combo rack spool & service deadender.

CLASS 46 -- Transpositions, all types.

289,449	12-4-83	N Rousseau. Double storm-shed pin type (U-197).
520,367	5-22-94	F Locke. Anti-leakage petticoats between conductors.
1,760,983	6-3-30	Gordon & Lowe (A T & T Co). Two-piece pin type.
1,761,046	6-3-30	C Pfautz. For spaced radio transmission lines.
2,043,754	6-9-36	E Johnson. " " " " " "
2,135,344	11-1-38	F Johnson (Crosley Radio Corp.) " " " "
2,138,571	11-29-38	R Dehmel (Bell Tel Labs) " " " "
2,195,986	-40	D Goddard (RCA Corp.) " " " "
2,305,688	12- -42	D Goddard (RCA Corp.) " " " "
2,455,227	11-30-48	R Case. Two-spool, midspan transposition.

CLASS 46 (continued)

2,455,228 11-30-48 R Case. Four-spool midspan transposition.
 2,455,229 11-30-48 R Case. Sim above, but fixed mounting on support.
 2,734,098 2-7-56 Bonnessen (A T & T). Elastic mid-skirt on CD-203.2

CLASS 50 -- Miscellaneous pin types & processes.

255,800 4-4-82 A Lewis. Key-type pin, keyed pin hole in insulator.
 276,839 5-1-83 J Lewis, England. Corkscrew top, Sim CD-110.5.
 281,452 7-17-83 T Chapman. Side hole with wire entrance slot.
 286,801 10-16-83 Fiske & Mott. Diamond-shapes in groove. CD-135
 288,360 11-13-83 S Oakman ($\frac{1}{2}$ Amer Insul Co). Recess above petticoat.
 290,922 12-25-83 Pope. Corkscrew top, opposed threads. CD-110.5
 315,660 4-14-85 H Prenzel. Two-piece, threaded top part. U-182
 317,479 5-5-85 W Wright. Vertical corrugations inside skirt.
 324,957 8-25-85 J Putnam. Base screws into crossarm peg hole.
 346,971 8-10-86 J Wilson. Top groove having rain spout at each end.
 347,454 8-17-86 J Wilson. Retainer ring over wire in crown groove.
 390,741 10-9-88 T Adams. Curved insulator, skirt still sheltering
 pin when conductor groove oriented vertically.
 406,041 7-2-89 J Gill (Hemingray Glass Co). Line wire cast into the
 insulator, spliced to conductor between poles. (!)
 425,513 4-15-90 W Kookogey. Upturned rainshed edges over conductor.
 430,296 6-17-90 S Oakman. Dovetails on crown hold wire. CD-259
 434,879 8-19-90 S Oakman. Annular projections on inside of skirt.
 437,685 10-7-90 T Gaynor. Reflector to shine light downward so
 insulator can be detected from others.
 443,187 12-23-30 F Bain. Horizontal skirt grooves, inner & outer.
 451,950 5-12-91 S Oakman. Holed wing for conductor. CD-263
 476,813 6-14-92 Pass & Seymour. Porcelain shell, porous cement inner
 to retain metal threads thimble. U-141 (unreported)
 496,652 5-2-93 R Hemingray & J Gill. Drip points on skirt bottom.
 503,039 8-8-93 W Essick. Crown groove, crown hole for tie wire.
 D. 22,684 8-8-93 L Gray. Knob-shaped pin type, crown groove. (14 yr)
 545,819 9-3-95 D Rothenberger. Crown groove & crown hole for tie.
 562,166 6-16-96 Blankinsop & Brown. Pin, internally reinforced with
 metal, screws directly into crossarm peg hole.
 D. 26,323 11-24-96 F Locke. Multipart top shell design. (7 years)
 573,092 12-15-96 F Locke. Glazeweld, outer shell more puncturable.
 590,806 9-28-97 F Locke. Oblong skirt with rain troughs. U-937
 600,475 3-8-98 J Boch. Glazewelding process, specifically U-928.
 601,195 3-29-98 J Boch. Extended petticoat, through crossarm.
 605,109 6-7-98 F Locke. Glazeweld, petticoat extends to crossarm.
 605,256 6-7-98 R Mershon. Long petticoat & ridges on skirt top.
 D. 30,637 4-25-99 V Converse. Specifically CD-283. (14 years)
 633,173 thru 633,176, 9-19-99, F Withycombe. Pin types with various
 outer ridges to cushion against impact blows.
 D. 31,798 and D.31,799, 11-7-99. Ditto immediately above. (14 years)
 D. 32,741 5-29-00 F Locke. Multipart crown with rain spouts. (14 yrs)
 657,574 9-11-00 A Sinding-Larson, Norway. Embedded electric heater,
 powered by induced e.m.f. from line conductor.
 664,301 12-18-00 R Sterling (Stanley Elec'c Mfg Co). Flatten cone
 with vertical flange, detachable rain spout on same.
 D. 34,211 3-12-01 L Stillwell. Specifically Niagara "E", U-966 (14 yr)
 D. 34,450 4-30-01 F Locke. Multipart crown design. (14 years)

CLASS 50 (continued)

676,881	6-25-01	H Ethridge. Locks to pin, but rotatable on same.
685,776	11-5-01	F Locke. Crossarm bolt draws down expanding sleeve plug to tighten to insulator pin hole.
689,171	12-17-01	Duffy & Hershey. Double crown with common base.
700,463	5-20-02	W Walther. Strengthening ribs, petticoat to skirt.
701,847	6-10-02	V Converse. Multiple stacked sections, pin type.
701,848	6-10-02	V Converse. Essentially identical to 701,847.
702,660	6-17-02	F Locke. Glazeweld, identical to Boch process.
702,661	6-17-02	F Locke. Molten glaze poured into joint, then cooled
724,848	4-7-03	F Gregory. One straight section of side-wire groove.
728,805	5-19-03	F Locke. Rain-diverting spout in top shell.
735,212	8-4-03	V Converse. Rase screws to pin. Top insulator on pin which itself screws into top of base part.
744,631	11-17-03	E Scoethaler. Enclosed side slots. CD-139
745,284	11-24-03	F Locke. Glazeweld at shoulders, air otherwise.
761,814	6-7-04	A Bease. Arrestor fuse inside unscrewable crown cap.
775,986	11-29-04	S Oakman. Severely flared skirt forms broad annular chamber to hold paraffin or similar substance.
776,789	12-6-04	F Locke. Horizontal surfaces on top two skirts.
778,005	12-20-04	C Booker, Canada. Cylindrical pin hole. Grooved pin and hole, Spring washer holds insulator to pin.
806,717	12-5-05	(R Thomas & Sons Co). Bottom piece of multi cemented to top assembly and rests tightly on crossarm.
822,211	5-29-06	F Locke. Glazeweld, flat junction surface.
831,168	9-18-06	A Lembeck. Second crown projects horizontally.
833,877	10-23-06	F Grant. Combo pintype crown, horizontal knob mount
836,122	11-20-06	F Locke. Tapered bolt in tapered hole of base part.
852,730	5-7-07	F Locke. Large skirt extends to crossarm.
867,901	10-8-07	J Barclay. Spiral tie-wire groove on crown. CD-147
876,828	1-14-08	R McNutt. Composition, with metal skirt, base coat and thread thimble, all secured with embedded studs.
880,971	3-3-08	G Carter. Tie over crown groove & thru peg also.
894,616	7-28-08	J Fay. Clamp insulator. Specifically, U-401.
917,031	4-6-09	C Eveleth (G.E. Co). Weakening grooves in skirt.
927,321	7-6-09	J Bond. Undercut side grooves plus vertical grooves.
954,350	4-5-10	A Siler. Convex crown conductor groove. Tie wire completely encircles crown, bending top conductor.
955,065	4-12-10	C Hardin. Conductor between pressure plates.
1,042,902	10-29-12	J Foutz. Screws into base attached to crossarm.
1,055,322	3-11-13	H DeLong. Two holes thru groove extend to pin.
1,140,050	5-18-15	Manwaring & Hessel. Also vertical grooves. U-189A
1,144,672	6-29-15	G Wheale. Fuse link between two side grooves
D. 49,538	8-22-16	W Goddard, Canada. Large-crown multipart. (14 yrs)
1,206,846	12-5-16	R Hopkins. Double-groove. Crown hole for wire ends.
1,229,272	6-12-17	J Irwin. Deep top groove, below brow of side groove.
1,361,948	12-14-20	J Widmyer. Pertains to mounting method.
1,663,421	3-20-28	Stubbings. Break-knob glazewelded to pintype crown.
1,708,038	4-9-29	L Wilson (A T & T Co). Whitall-Tatum #12. CD-176
2,165,773	7-11-39	Wheeler (Western Union Tel Co). "TS-3" CD-142.4
2,215,152	9-17-40	G Hosfield. Porcelain shell, live rubber interior.
2,218,497	10-15-40	Smith (Western Union). Vulcanized rubber.
2,274,955	3-3-42	(Victor Insulators, Inc.). Antimony coating on top portion of pin type for radio treatment.
2,304,483	12-8-42	(Western Union Tel Co). Vulcanized rubber.

CLASS 52 -- Oil resevoir, "no leak", and dry-spots.

524,659	8-14-94	G Winslow. Two-piece, bottom part with oil cup into which above petticoat extends to effect a seal.
771,297	10-4-04	Cummings (Stanley Elec'c Mfg Co). Oil resevoir.
882,803	3-24-08	L Storrer. "No Leak" CD-211
898,921	9-15-08	Purves & Sinnot, England. Screw-cap dry-spot with holes to dry chamber from wire grooves.
1,088,278	2-24-14	Holmes (Hemingray Glass Co). Metal base shield with spring fingers around skirt, for no rain splashing.
1,700,166	1-29-29	Johnson (A T & T Co). In-line dry-spot device.
1,703,853	2-26-29	R Gould (Postal Tel Cable Co). Dry-spot. U-173
2,381,676	8-7-45	M Mathews. Dry-spot, cap screws on same peg as base.
2,406,095	8-20-46	M Mathews. Dry-spot, one-piece construction.

CLASS 53 -- Fog types, Helicals, "Hi-Tops", etc.

1,677,346	7-17-18	R Jackson (Westinghouse). Fogbowl suspension.
1,706,488	3-26-29	Hawley (Locke). Fogbowl via metal pan bottom insert.
1,742,628	1-7-30	S Barfoed. Fog petticoats on bell-shaped suspension.
1,854,459	4-19-32	J Dienner. Upturned skirts, drain holes in each.
1,858,611	5-17-32	S Barfoed. Petticoats on bell-shaped suspension.
1,869,397	8-2-32	C Stroup. External helical petticoats, upturned.
1,942,284	1-2-34	Halton (England). Spiral petticoat on suspension.
1,955,609	4-17-34	Rowland (Locke). Fogbowl via glazewelding bottom.
2,084,866	6-22-37	Plimpton (Locke). Outer petticoats ("Hi-Tops").
2,088,433	7-27-37	Plimpton (Locke). Ruggedized Hi-Top. U-816 series.
2,155,848	4-25-39	Taylor (O-B). Long helical-petticoated suspension.
2,266,400	12-16-41	F Reed. Specifically, CD-219.

CLASS 54 -- Upside-down mounting under crossarm.

353,120	11-23-86	R Brown (Greeley & Co). Duplex pony.
484,209	10-11-92	F Locke. Regular pin & insulator inverted, rain-shedding pan held over insulator by pin to crossarm.
634,568	10-10-99	C Beal. Multi-petticoated, pin hole in top, central bottom tie post for conductor. Essentially U-400.
686,609	11-12-01	R Hemingray. Pin type mounted upright under cross-arm. Double-ended pin then allows upside-down mount of pony under the other insulator.
955,661	4-19-10	W Moore. Essentially U-400 but with metal cap fixed to crown and having wire-retaining lugs on same.
1,694,415	12-11-28	Gordon (A T & T Co). Multi-petticoated, inverted as U-400, tip cap screws on to provide shelf for wire.

CLASS 55 -- Self-tying, twist-lock or slack-wire types.

316,812	4-28-85	J O'Brien. One side hole with slanted entrance slot.
D. 27,756	10-19-97	S Graham. Horizontal wire slot in crown. (14 years)
D. 35,462	12-17-01	T King. Long "L" slot in crown. (14 years)
707,429	8-19-02	T King. Similar to above, but a form of twist-lock.
737,027	8-25-03	W Rutledge. Sinuous crown slot forms twist-lock.
740,314	9-29-03	Robertsons. Form of twist-lock.
831,388	9-18-06	M Glick. Form of twist-lock.
834,567	10-30-06	Falkenberg & Simon. Twist-lock.
881,967	3-17-08	C Slusser. Crown slot, "V" entrance. U-185
915,330	3-16-09	J Blackburn. Twist-lock.
1,059,629	4-22-13	T Platt. Triple-slot twist-lock.
1,107,111	8-11-14	B Purkey. Twist-lock top, slack wire. U-186
1,116,631	11-10-14	F Schisler. Slack-wire crown slot, metal lined.
1,217,032	2-20-17	C Lyon. Twist-lock onto wire, then attach to X-arm.
1,251,416	12-25-17	B Purkey. Identical U-186 but concentric ridges in slot termination to prevent wire from sliding thru.
1,302,796	5-6-19	T Heard. Inverted U-slot on side plate appendage.
1,382,483	6-21-21	J Decker. Twist-lock crown slots.
1,684,312	9-11-28	Fischer & Payne. Twist-lock type.

CLASS 56 -- Self-tying, fingers, or types which bend the conductor.

293,901	2-19-84	T McGrory. Angled slot on side of crown.
323,055	7-28-85	T McGrory. Three-finger hold in side of crown.
342,320	5-25-86	Blake/Trimmell. Three-fingers, both sides of crown.
347,635	8-17-86	J O'Brien. Side ears on toll. Specifically CD-119, specimens error-marked wrong O'Brien patent date.
367,164	7-26-87	H Ruger. Similar U-185 Slusser. Slot in crown side.
463,955	11-24-91	H Newell. Three-finger, on both sides of crown.
590,832	9-28-97	Grimm & Nessler. Vertical curved crown groove.
669,691	3-12-01	M Harloe. Two-piece. Fingers on crown.
715,375	12-9-02	M Harloe. One-piece. Three fingers on crown.
730,805	6-9-03	W Stroh. Sinuous slot down into crown top.
801,196	10-3-05	C Mathias. Crown side entrance to vertical slot.
821,401	5-22-06	T Carter. Sinuous vertical-to-horizontal slot.
888,616	5-26-08	C Johnson. Vertical crown slots, retaining notches.
929,878	8-3-09	J Ranson. Twist-lock, severe wire bend. U-183
986,702	3-14-11	D Friend. Vertical entrance to horizontal slot.
1,109,058	9-1-14	O Fritz. Vert. into horiz. center slot. Wire bends.
1,149,017	8-3-15	R Balliet. Wire kinked up in side groove fingers.
1,151,179	8-24-15	E Harris. V-shaped horizontal groove, severe bend.
1,174,002	2-29-16	V Ettinger. Long three-finger top arrangement.
1,177,315	3-28-16	W Gee. Groove brow & lip hook-shaped, bends wire.
1,200,294	10-3-16	Ayre et al. Vert slot, becoming curved, to wire seat
1,234,313	7-24-17	A Efrig. Three-finger type, each side of crown.
1,371,855	3-15-21	H Buller. Three-finger type in top of crown.
1,470,322	10-9-23	H Frederick. Bending fingers & notches side of crown
1,475,722	11-27-23	J Romandy. Bail item hinges down on top of and perpendicular to wire, snaps into place, bends wire.
2,266,340	12-16-41	N Sindlinger. Combo twist-lock to three-fingers.

CLASS 57 -- Self-tying, cap screws on to hold wire.

402,592	5-7-89	Heavyside (England). Cap presses wire into groove.
460,448	9-29-91	F Ross. Cap presses wire into groove, bending wire.
490,560	1-24-93	A Hauty. Cap vertically slotted for conductor.
544,778	8-20-95	Sproat & Tarr. Annular grooves on cap bottom hold conductor against base. Both pieces screw onto peg.
582,396	5-11-97	W Schnee. Wire in base groove. Cap twist-locks on.
585,026	6-22-97	R Delery. Flanged bottom with vertical wire slot. Screw-on cap threaded both sides for flange. (!)
619,555	2-14-99	I Frantz. Grooved plate on bottom piece for wires, cap screwing down onto same to hold wires in place.
626,592	6-6-99	Carpenter/Tonn. Yielding gaskets between cap & base.
664,432	12-25-00	E Renault. Vertical wire groove in threaded base.
671,876	4-9-01	W beardsley. Spring-loaded paul holds cap in place.
697,628	4-15-02	C Johnston. Cap presses conductor into base groove.
704,172	7-8-02	J Calvin. Radial cap corrugations lock on wire.
713,904	11-18-02	J Murray. Cap presses conductor into slot in base.
726,846	5-5-03	J Bell. Cap presses conductor into slot in base.
739,147	9-15-03	H Bottjer. Wire in split base, cap holding together.
759,276	5-10-04	C Hobert. Two pieces, both screwing onto peg. Cap presses conductor against base piece.
783,229	2-21-05	L Steinberger. Cap presses wire into slot in base.
802,397	10-24-05	C Humphrey. Base slotted. Cap presses plug into hole on base to apply pressure to conductor.
849,606	4-9-07	A Goldstein. Cap presses wire into slot in base.
872,756	12-3-07	Scherer & Fashbaugh. Wire in side groove L-shaped downward. Cap encloses entrance to said groove.
961,646	6-14-10	Reusch (Canada). Wire in split tube in base part. Cap screws down and closes end of tube to hold wire.
992,397	5-16-11	M Anderson. Two pieces connected with threaded plug. Cap holds conductor into groove in top of base part.
1,043,916	11-12-12	F Farwell. Cap presses conductor into slot in base.
1,048,390	12-24-12	F Brown. Cap presses conductor into slot in base.
1,146,201	7-13-15	S Nunn. Cap screws over vertical slot in base, but claims specify slack-wire use.
1,150,697	8-17-15	Neely & Lewis. Cap holds wire in annular base groove.
1,161,080	11-23-15	F Spicer. Base slides on peg, cap screwing onto top of peg. Cap overhangs base and retains conductor.
1,167,208	1-4-16	W Oppelt. Base has annular and coinciding parallel grooves, cap only annular grooves. Both parts screw onto peg. External ribs to facilitate tightening.
1,263,746	4-23-18	W Creamer. Cap presses wire into base slot. Radial cap grooves to catch wire in any position. Finger grip depressions in cap to aid tightening.
1,266,435	5-14-18	English (Canada). Vertical slot in base. Radial notches in bottom of cap catch wire in any position.
1,305,168	5-27-19	O Roberts. Base slides onto peg. Cap screws onto peg top to hold wire against base. Similar U-182.

CLASS 58 -- Self-tying, miscellaneous types.

274,821	3-27-83	W Reiff. Hook embedded into indented crown recess.
332,061	12-8-85	B Deblieux. Split halves enclose wire and then mount through hole in crossarm. Secured with nut on base.
346,972	8-10-86	J Wilson. Crown screw presses wire into horiz. slot.
347,943	8-24-86	J Leonardson. Vertical-plane cam presses wire into groove, cam secured by hooking end to conductor.
383,734	5-29-88	F Keyes. Conductor in vertical crown slot. Clip from groove to crown closes slot opening. Slack wire.
408,383	8-6-89	C Graham. Semi-twistlock crown slot. Three-piece wire bail holds conductor tightly in slot.
448,956	3-24-91	Graham/Gamane. Crown externally threaded for metal cap, screws down to lower wire-hooks attached to same and which pull conductor down in crown groove.
515,448	2-27-94	Schombourg (Germany). Toggle attached with bolt thru crown, toggle eccentric holding wire in crown slot.
546,383	9-17-95	G Gerstenlauer. Horizontal crown slot to large wire hole. Conductor held in hole with long tapered plug.
552,501	12-31-95	C Snively. Camming lever squeezes pressure plates above-below conductor. (Positively unbelievable!)
586,372	7-13-97	H Steinberg. Clip holds wire in irregular slit.
587,273	7-27-97	Rudolph (Germany). Vertical crown slot. Conductor in slot loops over securing pin perpendicular to it.
679,544	7-30-01	J Sharpe. Wedging ring slides down crown to squeeze conductor between side plate and crown.
711,629	10-21-02	C Hobert. Side slots turning downward and wedging.
712,440	10-28-02	J Shreffler. Screw through crown presses wire into horizontal slot in side of crown.
728,442	5-19-03	E Burke. Split wedges containing conductor drop into large crown recess. Wire weight increases clamping.
770,962	9-27-04	J Gill. Cross slots in crown. Plug screws down into hole between slots to hold conductor down.
789,573	5-9-05	L Steinberger. Plug cemented into crown of glass insulator. Cap presses conductor into plug slot.
798,235	8-29-05	W Twiggs. Convex L-shaped crown groove. Balls drop into groove over wire to retain wire movement by clutching action. Very clever, even tho impractical.
805,169	11-21-05	J Taubold. Rack-and-pinion cam squeezes wire between blocks. (You have to see this to believe it!)
844,796	2-19-07	A Hatchett. Spiral slot, wire retained at center.
865,697	9-10-07	Henderson & King. Upslanting ends of side groove.
866,596	9-17-07	W Morton. Large, threaded crown hole with side slot entrance. Threaded plug in hole, also slotted, also surrounds wire. Half turn of plug secures conductor.
872,216	11-26-07	H Bodley. Camming lever holds wire up against boss. Lever end-weighted to stay in clamping position. (!!)
900,917	10-13-08	G Dobson. Base ring rotates and moves upward on stepped notches to squeeze wire against top piece.
922,477	5-25-09	R Henry. Cap screws onto base. Tapered pegs through vert. cap holes retain wire in cap horiz. groove.
931,507	8-17-09	A Silver. Severely convex vertical groove in crown. Cross pins hold wire in place in groove, bending it.
944,259	12-28-09	A Dennler. Wire in side groove, preformed tie-wire hooking same and secured in notches on other side.
971,785	10-4-10	A Pierce. Slack-wire tree insulator. Cap holds wire in groove of base. Specifically, U-187.

CLASS 58 (continued)

980,495	1-3-11	G Crawford. Cylindrical serpentine wire slides over insulator, holding wire in insulator's side groove.
1,009,810	11-28-11	T Watkins. Large V-groove in crown. Plate snaps into groove, tongue in plate holding conductor.
1,032,153	7-9-12	M Nemes. L-clamp through crown hole, loops over conductor on one side. Tightens with wing-nut.
1,035,415	8-13-12	Brown & Brown. Embedded springs from base form harness-type snaps at groove to hold conductors.
1,090,686	3-17-14	W Cook. Large lever over crown holds wire in crown groove, snap-catch on nonhinged side holds lever.(!)
1,168,796	1-18-16	C French. Hollow cap with slits up bottom edges goes over central plug which has annular wire groove.
1,172,963	2-22-16	A Englehardt. Wire in top groove. Spring clip over wire and into notches on side of crown.
1,176,618	3-21-16	W Swearington. Pivoted rocker restrains lateral wire movement in annular side groove.
1,190,286	7-11-16	E Harlan. Two-piece crown encloses conductor. Catch on crown side holds top piece to bottom piece.
1,205,069	11-14-16	R Williams. Vertical crown slot to offset recesses.
1,208,874	12-19-16	W Wilson. Wire in side slot. Spring-loaded pincer dogs restrain wire movement laterally. (!!!)
1,241,929	10-2-17	Dade & Morgan. Inclined side slot. Wire retained by eccentric rotatable piece over wire in slot.
1,257,983	3-5-18	C DeVaughn. Large crown hole. Split, toothed pieces around wire through hole. Top of crossarm peg then prevents split pieces from moving laterally. (!)
1,260,160	3-19-18	C Disbennet. Plug in crown hole with slot for conductor. Plug then rotates to capture conductor.
1,291,139	1-14-19	R Reese. Vertical crown slot. Clamp squeezes wire, and horizontal crown pin holds clamp down in place.
1,509,074	9-16-24	J Wilson. Cap holds conductor down against base. Cap held to base by separate latches at side.
1,509,645	9-23-24	M Foss. Zig-zag crown slot in base. Cap mates zig-zag, held in place with horizontal pin thru crown.
1,516,884	11-25-24	H Frederick. U-shaped brackets, non-frangible, plus a nonfrangible insert. Operates as "three-fingers".
1,675,589	7-3-28	O Babineau. Two-piece. Wire in crown slot wedges between sliding pieces.
1,829,354	10-27-31	Houde (Canada). Side slot turns downward toward center. End of pivoted lever holds wire down and is retained by other end snapping into side groove.

CLASS 60 -- Tie-wire clips, clamps and bails.

313,377	3-3-85	W Sawyer. One-piece, semicircular groove-hook.
434,144	8-12-90	J Dunbar. Clip wired to side groove. Conductor in bend of clip, held in by wedge thru holes in clip.
465,961	12-29-91	G S Albanese. 3-piece bail wire on ordinary pony. (Advertised as "G.S.A. line wire holder" in 1892.)
491,208	2-7-93	W Edmunds. One-piece, semicircular groove-hook.
557,881	4-7-96	H Rappleye. Three-piece bail wire, insulator having second groove for base wire of bail system.
558,509	4-21-96	G Middleton. Two-piece bail with camming pall.

CLASS 60 (continued)

601,454	3-29-98	A Weikman. Bail wire system, standard insulators.
609,888	8-30-98	S Leonard. Two-piece clamp on wire, with large band around groove. Secured together with nut on band.
619,915	2-21-99	F Wentworth. Semicircular groove hook, spring wire.
782,676	2-14-05	Macek (Austria). Three-element wire clamp.
814,889	3-13-06	H Swanson. Loop around insulator groove to pivot of camming level which holds conductor in place.
864,599	8-27-07	Becketts. Clamp wired to insulator groove. Conductor through clamp slot, held with set screw in clamp.
882,095	3-17-08	W Callane. One-piece spring wire, hooks conductor on both sides insulator, snaps into groove other side.
887,930	5-19-08	C Elliott. Two-piece spring wire, one piece camming other to tightness, latching on conductor to secure.
907,788	12-29-08	A Hall. U-shaped clip and stirrup latch.
934,352	9-14-09	J Pratt (U.S. Army). Semicircular groove hook.
966,882	8-9-10	Banfield (England). Clip around groove ends in pierced forks, through which conductor runs. Pegs through pierced holes hold slightly bent conductor.
992,595	5-16-11	L Ridenour. Bridle ring tie-wired to insulator side groove. Conductor runs slack-wire through ring.
1,048,587	12-31-12	Rieffer & Mays. Split band around insulator with end clamp. Conductor secured by rotated staple in clamp.
1,067,246	7-15-13	J Hubbard. One-piece bail, sheet metal cam lever.
1,105,521	6-28-14	J Kephart. Band in bottom groove with lever to press on conductor. Band in upper groove with loop to hold end of said lever. (Simply unbelievable!)
1,119,049	12-1-14	A Smith. Three-piece, wire plus bell crank levers.
1,215,245	2-6-17	R Boyter. Two sheet metal parts clamp conductor at sides, hook together on back side of wire groove.
1,247,531	11-20-17	V Head. Wire around insulator with hook in each end to catch conductor. Special tool aids installation.
1,346,128	7-13-20	Krebs (Denmark). Wire ends catch conductor. Camming levers on back side tighten system over dead center.

CLASS 62 -- Protective metal shields over glass insulators.

396,334	1-15-89	S Gilson. Insulator of Gilsonite compound enclosed in a surrounding metal case except at top.
566,045	8-18-96	Whitaker (England). Metal shell completely encloses.
580,628	4-13-97	Treharne (England). Very similar to #566,045.
787,442	4-18-05	Flynt & Leaman. Two sheet metal halves attach together to enclose insulator from rim up over top.
909,935	1-19-09	J Rea. Glass insulator cemented into metal casing.
983,039	1-31-11	J Field. Two metal halves clip together over entire insulator. Loop in metal crown for conductor.
1,659,731	2-21-28	E Green. Large metal crown and skirt attached to glass bottom part, which then screws onto peg.
1,678,663	7-31-28	Wilson (A T & T Co). Entire skirt to wire groove is metal, attached to central glass part.
2,099,540	11-16-37	Smith (W.U. Tel. Co.). Two-part metal cases encloses skirt of CD-152 glass, protect from thrown missiles.
2,135,558	11-8-38	P Bott. Metal "pan" upwards underneath insulator, resilient or deformable, protects from missiles.

CLASS 64 -- Wire-groove protector bands.

- 527,317 10-9-94 E Bullock. Metal wearing surface on groove, top cap of insulator removable by unscrewing.
592,505 10-26-97 W Barbour. Glass interior, elastic outer shell with groove containing a metal wearing band.

CLASS 66 -- Metal/composition combinations with top cable clamps.

- 520,602 5-29-94 H Luscomb. Metal interior, composition encapsulated, metal outer shield. Top ears bend over cable.
520,855 6-5-94 Lieb (G.E. Co.). Top ears bend down over cable. Inside portion of assembly is insulating material.
522,175 6-26-94 J Anderson. Cap screws down onto top ears to secure cable in crown structure. Insulation interior.
530,706 12-11-94 L McCarthy. Metal-composition-metal as #520,602 above. Top ears bend down over cable.
578,825 3-16-97 Luscomb (Johns-Pratt Co.). Metal case, composition interior. Pivoted cable holder on crown structure.
595,827 12-21-97 C Woolsey. Clamped-on cap holds insulator blocks. Set screw tightens plug down against conductor.
1,249,820 12-11-17 Pharo (Westinghouse). Metal case on composition. Rotatable plate for wire groove at any position.

CLASS 80 -- Pegs and pin brackets. (very selective listing)

- 436,120 9-9-90 H Chubbuck. Wall L-bracket, resilient-material pin.
463,587 11-17-91 V Thomas. Double-pin wall bracket, cast.
463,588 11-17-91 V Thomas. Similar, double-pins are horizontal.
493,434 3-14-93 F Locke. Two-piece, hollow base plus wooden cob.
510,809 12-12-93 F Locke. Two-piece. Hollow metal base screwed to crossarm. Wooden cob attached by bolt or lag screw.
D. 24,249 4-23-95 L Beardsley. Ribbed metal post with contiguous metal cob, slotted vertically.
557,600 4-7-96 C Peterson. Metal rod with coil of wire attached thereto for threads.
565,944 8-18-96 C Toward. J-form transposition bracket, peg above crossarm plus one underneath crossarm.
566,468 8-25-96 (Oliver Iron & Steel Co). Petticoat rests on flange of pin. Hemp used between peg and glass threads.
602,576 4-19-98 J Fletcher. L-shaped pin with surface to drive pin into pole, both vertical & horizontal pin modes.
687,230 11-26-01 T Hallet. Two stamped halves attached to center support piece.
701,063 5-27-02 F Locke. Wooden cob driven onto metal pin with rows of retaining barbs to secure cob.
878,679 2-11-08 W Smith. Large cast pin structure, held to crossarm by large U-bolt surrounding entire crossarm section.

CLASSES 82, 86 and 88 not itemized herein.

TRADEMARKS

Trademarks for insulators registered with the U.S. Patent Office are tabulated below. This list may be helpful in attributing specimens or the manufacturing source for various products shown in directories, catalogs and trade journal notices. Company addresses, classes of products covered by the trademark and the "used since" dates are not detailed, but this information can be readily obtained by consulting the Official Gazettes. Trademarks associated exclusively with high-voltage insulators are not tabulated. Trademarks for fibre or composition insulators are shown for companies making insulators related to power distribution wiring.

It is interesting to note that many widely used trademarks were not registered, and this includes most of the catchy nail knob trademarks of the boom years. Also note that some were in use for many years until being registered, such as the Star Porcelain Company trademarks being used "since 1899" and finally registered in 1949. The asterisks indicate that the trademark was renewed for an additional 20-year period (*) or for two additional 20-years periods (**).

Number	Date	Company	Trademark
22,148	12-6-92	Albert & J. M. Anderson Mfg. Co.,	"AETNA"
22,623**	3-7-93	E. Munsell et al,	"MICANITE"
25,007	7-10-94	J. S. Porter,	"CARTWRIGHT"
25,088	7-31-94	W. T. C. Macallen Co.,	"MACALLEN"
29,217	11-24-96	Hart & Hegeman Mfg. Co.,	Monogram-(H & H M Co)
32,239	12-13-98	Ohio Brass Co.,	"DIRIGO"
32,544*	2-28-99	Albert & J. M. Mfg. Co.,	"HECLA"
34,266	2-27-00	Falcon Elec. Mfg. Co.,	"FALCON"
35,204	10-2-00	Western Electric Supply Co.,	"WESCO"
36,186	4-2-01	Electric Storage Battery Co.,	"EXIDE"
36,305	4-23-01	Franklin Elec. Mfg. Co.,	"FEMCO"
36,306	4-23-01	" " " "	, kite body
36,307	4-23-01	" " " "	, kite with tail, in flight
38,554	7-1-02	D. M. Steward Mfg. Co.,	"LAVITE"
39,410*	12-2-02	Mica Insulator Co.,	"EMPIRE"
39,411*	12-2-02	" " " "	, "LINOTAPE"
39,856	2-21-03	Hart Mfg. Co.,	(a diamond)
43,265	8-30-04	American Mica Co.,	"NUMICA"
44,477**	7-4-05	W. T. C. Macallen Co.,	Diamond-MACALLEN
45,644	8-22-05	American Mica Co.,	"NUMICA"
45,880	8-29-05	Bryant Electric Co.,	"BRYANT"
50,462	3-20-06	Grouse-Hinds Co.,	(a diamond)
50,463	3-20-06	" " " "	, "CONDULET"
56,013	8-21-06	Johns-Pratt Co.,	"JOHNS-PRATT"
59,316	1-8-07	Bryant Electric Co.,	"Junior"
59,317	1-8-07	" " " "	, "JR."
60,741	2-19-07	Trumbull Electric Mfg. Co.,	Circle-T
61,434	3-19-07	American Mica Co.,	"MICABESTON"
61,992	4-16-07	George Cutter Co.,	"Jupiter"
65,586	10-8-07	Electric Service Supplies Co.,	"KEYSTONE"
67,282	1-28-08	The Arrow Electric Co.,	(arrow through "E")
67,753	2-18-08	Appleton Electric Co.,	"WIRELETS"
69,532	6-16-08	" " " "	, "UNILETS"
69,643*	6-23-08	Albert & J. M. Anderson Mfg. Co.,	"AETNA"
70,202*	8-11-08	" " " " " "	, "AEA/AETNA" in a drawing
70,904	10-13-08	Ajax Line Material Co.,	"AJAX"

70,992	10-20-08	Johns-Pratt Co., "J. P. Co."
71,259	11-10-08	" " " , "MOULDED / MICA"
71,260	11-10-08	Manhattan Electrical Supply Co., "MESCO"
71,568	12-1-08	The Wesco Supply Co., ("WESCO" on a shield)
71,992	12-29-08	Crouse-Hinds Co., (see illustration below)
72,721	2-16-09	Pass & Seymour, Inc., "P & S"
72,865	3-2-09	Fairmount Electric & Mfg. Co., "BENDHICKS"
76,338	1-4-10	Delta-Star Electric Co., (see illustration below)
76,814	2-15-10	Charles S. Knowles Co., Monogram-CSK
78,058	5-31-10	Appleton Electric Co., Triangle-A
80,769	1-31-11	Electric Service Supplies Co., (see illustration)
81,797	5-9-11	Elec'l Engineers Equipment Co., (see illustration)
82,254	6-13-11	James C. Phelps, "CAPLETS"
82,555	7-11-11	Arrow Electric Co., "ARROW"
86,119	4-16-12	" " " , "FORTY"
88,160	9-3-12	The Bonnell Mfg. Co., "ADAPT i BOX"
88,325	9-10-12	Mica Insulator Co., "KABLAK"
90,150	2-14-13	Wirt Electric Specialty Co., "DI-EL-ITE"
90,295	2-18-13	Crouse-Hinds Co., "CONDULETTO"
95,822	3-17-14	Electrose Mfg. Co., "ARCOVER"
98,999	8-11-14	Elisha W. Buffinton, "B & D"
107,575	12-14-15	Illinois Electric Porcelain Co., Triangle-M
114,735	1-2-17	The Findlay Electric Porcelain Co., "BUCK EYE"
147,509	10-18-21	J. H. Parker & Son, "NAILIT"
152,651	3-7-22	Ajax Electric Specialty Co., ("AJAX" stylized)
158,544*	9-5-22	Square-D Co., Square-D
159,796	10-10-22	American Insulator Co., "AICO"
172,397*	8-28-23	Illinois Electric Porcelain Co., "BULL-DOG"
188,590	-24	Trenton Porcelain Co., "LITTLE JOE"
188,591	-24	" " " , "BIG JOE"
191,415	-24	" " " , "MEDIUM JOE"
198,982*	6-2-25	Illinois Elec'c Porcelain Co., ("Bull Dog" stylized)
199,077	6-2-25	Trenton Porcelain Co., "LITTLE JOE"
231,101	8-9-27	General Porcelain Co., "GEE PEE"
248,390	-28	Porcelain Products, Inc. (see illustration below)
266,285	1-14-30	Electric Service Supplies Co., (see illustration)
278,282	12-16-30	Porcelain Products, Inc. "ALLIGATOR"
285,224	7-21-31	Isolantite Co. of America, Inc., "CERRISO"
328,112	9-17-35	Porcelain Products, Inc., "SLATITE"
335,999	6-23-36	Illinois Electric Porcelain Co., Triangle-M
352,703	12-7-37	Trumbull Electric Co., "CARBONOT"
360,986	10-4-38	Porcelain Products, Inc., "UNI-TYPE"
374,997	2-6-40	Superior Porcelain Co., "S. P. Co."
393,274	2-3-42	Westinghouse Electric & Mfg. Co., "PRESTITE"
403,681	10-12-43	U. S. Quarry Tile Co., "DIA-MON-ITE"
420,133	3-26-46	" " " " , "SAPPHIRITE"
432,107	8-19-47	The Universal Clay Products Co., Circle-U
502,121	9-14-48	Illinois Electric Porcelain Co., "ILLINOIS"
518,499	12-6-49	The Star Porcelain Co., (a five-pointed star)
518,500	12-6-49	" " " " , "STAR"



#71,992



#76,338



#81,797



#248,390



80,769
#266,285

APPENDIX A

T U E S D A Y S -- 1836 to 2000

Use the table below to determine which column to use in the table at the right. For example, use column 9 for the year 1912. Then column 9 shows all the dates in 1912 which were Tuesdays.

C O L U M N I N D E X		
1836--13	1891---5	1946---3
1837---1	1892--13	1947---4
1838---2	1893---1	1948--12
1839---3	1894---2	1949---7
1840--11	1895---3	1950---1
1841---6	1896--11	1951---2
1842---7	1897---6	1952--10
1843---1	1898---7	1953---5
1844---9	1899---1	1954---6
1845---4	1900---2	1955---7
1846---5	1901---3	1956---8
1847---6	1902---4	1957---3
1848--14	1903---5	1958---4
1849---2	1904--13	1959---5
1850---3	1905---1	1960--13
1851---4	1906---2	1961---1
1852--12	1907---3	1962---2
1853---7	1908--11	1963---3
1854---1	1909---6	1964--11
1855---2	1910---7	1965---6
1856--10	1911---1	1966---7
1857---5	1912---9	1967---1
1858---6	1913---4	1968---9
1859---7	1914---5	1969---4
1860---8	1915---6	1970---5
1861---3	1916--14	1971---6
1862---4	1917---2	1972--14
1863---5	1918---3	1973---2
1864--13	1919---4	1974---3
1865---1	1920--12	1975---4
1866---2	1921---7	1976--12
1867---3	1922---1	1977---7
1868--11	1923---2	1978---1
1869---6	1924--10	1979---2
1870---7	1925---5	1980--10
1871---1	1926---6	1981---5
1872---9	1927---7	1982---6
1873---4	1928---8	1983---7
1874---5	1929---3	1984---8
1875---6	1930---4	1985---3
1876--14	1931---5	1986---4
1877---2	1932--13	1987---5
1878---3	1933---1	1988--13
1879---4	1934---2	1989---1
1880--12	1935---3	1990---2
1881---7	1936--11	1991---3
1882---1	1937---6	1992--11
1883---2	1938---7	1993---6
1884--10	1939---1	1994---7
1885---5	1940---9	1995---1
1886---6	1941---4	1996---9
1887---7	1942---5	1997---4
1888---8	1943---6	1998---5
1889---3	1944--14	1999---6
1890---4	1945---2	2000--14

	1	2	3	4	5	6	7	8	9	10	11	12	13	14
J	3	2	1	7	6	5	4	3	2	1	7	6	5	4
1 A	10	9	8	14	13	12	11	10	9	8	14	13	12	11
N	17	16	15	21	20	19	18	17	16	15	21	20	19	18
	24	23	22	28	27	26	25	24	23	22	28	27	26	25
	31	30	29	--	--	--	--	31	30	29	--	--	--	--
F	7	6	5	4	3	2	1	7	6	5	4	3	2	1
2 E	14	13	12	11	10	9	8	14	13	12	11	10	9	8
B	21	20	19	18	17	16	15	21	20	19	18	17	16	15
	28	27	26	25	24	23	22	28	27	26	25	24	23	22
	--	--	--	--	--	--	--	--	--	--	--	--	--	29
M	7	6	5	4	3	2	1	6	5	4	3	2	1	7
3 A	14	13	12	11	10	9	8	13	12	11	10	9	8	14
R	21	20	19	18	17	16	15	20	19	18	17	16	15	21
	28	27	26	25	24	23	22	27	26	25	24	23	22	28
	--	--	--	--	31	30	29	--	--	--	31	30	29	--
A	4	3	2	1	7	6	5	3	2	1	7	6	5	4
4 P	11	10	9	8	14	13	12	10	9	8	14	13	12	11
R	18	17	16	15	21	20	19	17	16	15	21	20	19	18
	25	24	23	22	28	27	26	24	23	22	28	27	26	25
	--	--	30	29	--	--	--	--	30	29	--	--	--	--
M	2	1	7	6	5	4	3	1	7	6	5	4	3	2
5 A	9	8	14	13	12	11	10	8	14	13	12	11	10	9
Y	16	15	21	20	19	18	17	15	21	20	19	18	17	16
	23	22	28	27	26	25	24	22	28	27	26	25	24	23
	30	29	--	--	--	--	31	29	--	--	--	--	31	30
J	6	5	4	3	2	1	7	5	4	3	2	1	7	6
6 U	13	12	11	10	9	8	14	12	11	10	9	8	14	13
N	20	19	18	17	16	15	21	19	18	17	16	15	21	20
	27	26	25	24	23	22	28	26	25	24	23	22	28	27
	--	--	--	--	30	29	--	--	--	--	30	29	--	--
J	4	3	2	1	7	6	5	3	2	1	7	6	5	4
7 U	11	10	9	8	14	13	12	10	9	8	14	13	12	11
L	18	17	16	15	21	20	19	17	16	15	21	20	19	18
	25	24	23	22	28	27	26	24	23	22	28	27	26	25
	--	31	30	29	--	--	--	31	30	29	--	--	--	--
A	1	7	6	5	4	3	2	7	6	5	4	3	2	1
8 U	8	14	13	12	11	10	9	14	13	12	11	10	9	8
G	15	21	20	19	18	17	16	21	20	19	18	17	16	15
	22	28	27	26	25	24	23	28	27	26	25	24	23	22
	29	--	--	--	--	31	30	--	--	--	--	31	30	29
S	5	4	3	2	1	7	6	4	3	2	1	7	6	5
9 E	12	11	10	9	8	14	13	11	10	9	8	14	13	12
P	19	18	17	16	15	21	20	18	17	16	15	21	20	19
	26	25	24	23	22	28	27	25	24	23	22	28	27	26
	--	--	--	30	29	--	--	--	--	30	29	--	--	--
O	3	2	1	7	6	5	4	2	1	7	6	5	4	3
10 G	10	9	8	14	13	12	11	9	8	14	13	12	11	10
T	17	16	15	21	20	19	18	16	15	21	20	19	18	17
	24	23	22	28	27	26	25	23	22	28	27	26	25	24
	31	30	29	--	--	--	--	30	29	--	--	--	--	31
N	7	6	5	4	3	2	1	6	5	4	3	2	1	7
11 O	14	13	12	11	10	9	8	13	12	11	10	9	8	14
V	21	20	19	18	17	16	15	20	19	18	17	16	15	21
	28	27	26	25	24	23	22	27	26	25	24	23	22	28
	--	--	--	--	30	29	--	--	--	--	30	29	--	--
D	5	4	3	2	1	7	6	4	3	2	1	7	6	5
12 E	12	11	10	9	8	14	13	11	10	9	8	14	13	12
G	19	18	17	16	15	21	20	18	17	16	15	21	20	19
	26	25	24	23	22	28	27	25	24	23	22	28	27	26
	--	--	31	30	29	--	--	--	31	30	29	--	--	--

APPENDIX B

Year	First number issued in the year			
	Patents	Designs	Reiss.	Tr'mrks
1836	1			
1837	110			
1838	546		1	
1839	1,061		7	
1840	1,465		20	
1841	1,923		30	
1842	2,413		36	
1843	2,901	1	49	
1844	3,395	15	60	
1845	3,873	27	67	
1846	4,348	44	78	
1847	4,914	103	91	
1848	5,409	163	105	
1849	5,993	209	128	
1850	6,981	258	158	
1851	7,865	341	184	
1852	8,622	431	209	
1853	9,512	540	229	
1854	10,358	628	258	
1855	12,117	683	286	
1856	14,009	753	337	
1857	16,324	860	420	
1858	19,010	973	517	
1859	22,477	1,075	613	
1860	26,642	1,183	674	
1861	31,005	1,366	1,106	
1862	34,045	1,508	1,253	
1863	37,266	1,703	1,369	
1864	41,047	1,879	1,596	
1865	45,685	2,018	1,844	
1866	51,784	2,239	2,140	
1867	60,658	2,533	2,430	
1868	72,959	2,858	2,830	
1869	85,503	3,304	3,250	
1870	98,460	3,810	3,784	1
1871	110,617	4,547	4,223	122
1872	122,304	5,452	4,687	608
1873	134,504	6,336	5,216	1,099
1874	146,120	7,083	5,717	1,591
1875	158,350	7,969	6,200	2,150
1876	171,641	8,884	6,831	3,283
1877	185,813	9,686	7,452	4,427
1878	198,733	10,385	8,020	5,463
1879	211,078	10,975	8,529	6,918
1880	223,211	11,567	9,017	7,790
1881	236,137	12,082	9,523	8,139
1882	251,685	12,647	9,994	8,973
1883	269,820	13,508	10,265	9,920
1884	291,016	14,528	10,432	10,822
1885	310,163	15,678	10,548	11,843
1886	333,494	16,451	10,677	12,910
1887	355,291	17,046	10,793	13,939
1888	375,720	17,995	10,892	15,072
1889	395,305	18,830	10,978	16,131
1890	418,665	19,553	11,053	17,360
1891	443,987	20,439	11,137	18,775
1892	466,315	21,275	11,217	20,537
1893	488,976	22,092	11,298	22,274
1894	511,744	22,994	11,397	23,951
1895	531,619	23,922	11,461	25,757
1896	552,502	25,037	11,520	27,586
1897	574,369	26,482	11,581	29,399
1898	596,467	28,113	11,646	31,070
1899	616,871	29,916	11,706	32,308

Year	First number issued in the year			
	Patents	Designs	Reiss.	Tr'mrks
1900	640,167	32,055	11,879	33,957
1901	664,827	33,813	11,979	35,678
1902	690,385	35,547	11,960	37,606
1903	717,521	36,187	12,070	39,612
1904	748,567	36,723	12,189	41,798
1905	778,834	37,380	12,299	43,956
1906	808,618	37,766	12,428	48,466
1907	839,799	38,391	12,587	59,014
1908	875,679	38,980	12,738	66,892
1909	908,436	39,737	12,906	72,088
1910	945,010	40,424	13,066	76,267
1911	980,178	41,063	13,189	80,506
1912	1,013,095	42,073	13,346	84,711
1913	1,049,326	43,415	13,504	89,731
1914	1,083,267	45,098	13,668	94,796
1915	1,123,212	46,813	13,858	101,613
1916	1,166,419	48,358	14,040	107,875
1917	1,210,389	50,117	14,238	114,666
1918	1,251,458	51,629	14,417	120,005
1919	1,290,027	52,836	14,582	124,066
1920	1,326,899	54,359	14,785	128,274
1921	1,364,063	56,844	15,018	138,556
1922	1,401,948	60,121	15,257	150,210
1923	1,440,362	61,748	15,513	163,003
1924	1,478,996	63,675	15,739	177,848
1925	1,521,590	66,346	15,974	193,597
1926	1,586,040	69,170	16,240	207,437
1927	1,612,790	71,772	16,515	222,401
1928	1,654,521	74,159	16,841	236,987
1929	1,696,897	77,347	17,176	251,129
1930	1,742,181	80,254	17,550	265,655
1931	1,787,424	82,966	17,917	278,906
1932	1,839,190	85,903	18,312	290,313
1933	1,892,663	88,847	18,705	299,926
1934	1,941,449	91,258	19,038	309,066
1935	1,985,878	94,179	19,409	320,441
1936	2,026,516	98,045	19,804	331,338
1937	2,066,309	102,601	20,226	342,070
1938	2,104,004	107,738	20,610	353,324
1939	2,142,080	112,765	20,959	363,536
1940	2,185,170	118,358	21,311	374,062
1941	2,227,418	124,503	21,683	384,047
1942	2,268,540	130,989	21,992	392,581
1943	2,307,007	134,717	22,242	399,378
1944	2,338,081	136,946	22,415	404,974
1945	2,366,154	139,862	22,585	411,001
1946	2,391,856	143,386	22,706	418,494
1947	2,413,675	146,165	22,827	426,610
1948	2,433,824	148,267	22,957	435,590
1949	2,457,797	152,235	23,086	441,742
1950	2,492,944	156,686	23,186	443,654
1951	2,536,016	161,404	23,320	444,377
1952	2,580,379	165,568	23,449	444,623
1953	2,624,046	168,527	23,612	568,680
1954	2,664,562	171,241	23,763	581,249
1955	2,698,434	173,777	23,918	600,188
1956	2,728,913	176,490	24,105	618,396
1957	2,775,762	179,467	24,263	639,154
1958	2,818,567	181,829	24,413	656,643
1959	2,866,973	184,204	24,584	671,998
1960	2,919,443	186,973	24,761	690,716
1961	2,966,681	189,516	24,918	709,163
1962	3,015,103	192,004	25,107	725,762

APPENDIX C

Patent Class 174 -- Subclasses 137 through 212

- 137 Insulators (unspecified)
- 138 Spcl applications -- insulate or support items other than conductors
- 139 Insulators combined with other devices -- shields, heat coils, etc.
 - 140 Combined items modify electrical characteristics -- arcing horns, conductive coatings, conductive gradient means, etc.
 - 141 Two or more separate units in series -- suspensions, etc.
 - 142 Insulate through a wall or plate
 - 143 Condensers
 - 144 Arcing or grading devices per se
 - 145 Combined with means for connecting two or more conductors
- 146 Mid-span spacers per se (not transpositions)
 - 147 Cross-overs (not transpositions)
- 148 Multiple. Two or more parts, each capable of independent operation
 - 149 Support two or more wires in spaced relationship (includes racks)
 - 150 All items in series, not independently -- strings and stacks
- 151 Insulates from wall or plate, conductor passing through same
 - 152 Where part of the insulator also passes through the wall hole
 - 153 Insulator engaging both sides of the wall
- 154 Insulator mounted in ring or clamp, all surrounding the conductor
 - 155 Divided insulator -- insulating blocks held in clamps, etc.
- 156 Divided insulators, two or more parts, with one or more conductor passages (self-tying units with caps, etc.)
 - 157 With aligned nail holes for mounting (cleats, nail knobs, etc.)
- 158 Combined with means for attaching to a supporting structure
 - 159 Insulated nail or staple
 - 160 Insulator engages flexible strand (span wire or messenger cable)
 - 161 Insulator adjusts on supporting structure -- flexible or hinged pins, swinging tree insuls, etc. Some strains & suspensions
 - 162 Insulator between brackets, flanges or crossarms -- clevis types, pin-type deadend insulators, etc.
 - 163 Item embracing insulator or support, or both -- pins wrapped around crossarms, etc.
 - 164 Attaching means extends into or through the support
 - 165 Part of attaching means secured in a socket in the insulator body -- wireholder lag screws, etc. (Incorrectly includes many pin types with more important invention claims.)
 - 166 One or more nail or screw holes -- solid knobs, etc.

- 167 At least one through-perature for conductors (includes spools, etc.)
- 168 Means for securing one or more conductors (many self-tying types)
 - 169 Conductor secured to item which itself is attached to the insulator (special tie-wire clips, etc.)
 - 170 Where the intermediate items is a "hook"
 - 171 Special for noncircular conductors
 - 172 Conductor held with clamp embracing insulator (bail wires, etc.)
 - 173 With tie wire twisted around both the conductor & insulator
 - 174 Insulator body modified to accept conductor -- some self-tying knobs, special pin types like Gregory, O'Brien, etc. (Incorrectly includes a number of other knobs and pin types.)
 - 175 Generally self-tying items, knobs and pin types
- 176 Insulators with one or more terminals
 - 177 Two or more terminals
 - 178 With two or more insulating parts, sections or materials
 - 179 Elongated insulating core inside tubular structure of other insulating material
 - 180 Pin in socket, other end capped (cap-type pin insulators)
 - 181 Internal metallic element, insulated from terminals, interlocks with terminals to reinforce (certain strain types)
 - 182 Secured pin on one end, cap on other end (suspensions per se)
 - 183 End terminals overlap, but not interlocking (certain strains)
 - 184 Overlapping terminals interlock (certain strains)
 - 185 Pin in one end, other end coaxially positioned over same
 - 186 Both ends are caps (strains, including Whse wooden strains)
 - 187 Single terminal, ventilation of chamber inside insulator body
 - 188 Single cap terminal (188-193 pertain mostly to suspension insuls)
 - 189 Insulator molded, cemented or alloyed into the cap
 - 190 Cap longitudinally divided to allow assembly
 - 191 Clamp, clasp or set screws secure insulator body into cap
 - 192 Rings or wedges between body and cap to secure same
 - 193 Insulator body screws or bayonet-plugs into the cap
 - 194 (next page please)

- 194 Pin type terminals (general)
 - 195 Generally, ordinary multipart pin type insulators
 - 196 Concerning pin held in with plastic material or cement
 - 197 Pin held in with clamp or clasp
 - 198 Pin held in with ring or wedge between pin and insulator body
 - 199 Pin having portion expanded to secure it in insulator
 - 200 Pin-hole thimbles
 - 201 Pin hole extended through insulator (mine insulators, etc.)
 - 202 Threaded or bayonet pin types
 - 203 Coil springs (and wound strands) for threads
 - 204 Sheet metal threads
 - 205 Soft or yielding thread (on pin or on insulator)
 - 206 Standard threaded pin type (incorrectly includes some pin types with invention not concerning the pin hole)
 - 207 Link, clevis or loop through or around insulator -- strains and Hewlett-type linkages
- 208 With grooves or openings for link, clevis or loop -- strains, etc.
- 209 Insulators composed of: (1) Two or more parts assembled to make a single unit, (2) Coated with other insulating material, but not radio-treated items, (3) With mechanical reinforcements having no electrical function.
- 210 Nested insulator body elements (glazewelds)
- 211 Insulator structure sheds rain, dirt, fog, etc. -- drip points, fogbowls, spirals, helicals, etc.
- 212 External configuration specially designed to modify electrical or mechanical character -- strengthening ribs, frangible types, tool-engaging surfaces, etc.

Other Class 174 subclasses pertinent to insulators:

- 2 Lightning protection
 - 3 Rods
- 32 Anti-inductive structures
 - 33 Conductor transpositions
 - 35 Shielded or screened
- 40 Overhead
 - 41 With messenger cable
 - 44 With connector or wire-fanning arrangements

REFERENCE CREDITS

- Barth, Harold, History of Columbiana County (Ohio), 1926, p-217.
- Brewer-Tichner Corp., The History of Hi-Line Hardware Since 1882. Related early history of porcelain insulators, 1960, pp 1-8.
- The Electrical Engineer, trade journal periodical, various issues 1890 to 1910.
- EMF Electrical Year Book, an encyclopedia of current information about each branch of the electrical industry, with a dictionary of electrical terms and a classified directory of electrical and related products and manufacturers. First Annual Edition, June 1921, 1406 pages.
- Harney, William J., Scrapbook, as published serially in the Sunday Times-Advertiser, Trenton, N.J., 7-7-29 through 7-28-29, vertical file of the Trenton Free Library. A history of the pottery industry in and near Trenton, N.J.
- National Electrical Manufacturers Association, Electrical Porcelain, a booklet describing the manufacture and use of electrical porcelain, its mechanical and electrical properties, 16 pp.
- Stout, Wilber, et al, History of the Clay Industry, as published in the Geological Survey of Ohio, 4th Series, Bulletin 26, 1923, pp 84-87.
- Tod, Jack H., Porcelain Insulators Guide Book for Collectors, evolution of the industry, and histories of porcelain insulator manufacturers. Second Edition, 1976, 160 pp. (See bibliography.)
- Vodrey, Jr., William H., Record of Pottery Industry in East Liverpool District (Ohio). Paper published in Bulletin of the American Ceramic Society, 1945, Vol. 24, No. 8, pp 282-288.
- Watts, Arthur S., Early History of Electrical Porcelain Industry in the United States. Paper published in Bulletin of the American Ceramic Society, 1939, Vol. 18, No. 10, pp 404-408.

Additionally, this research relied upon:

- (1) The insulator catalogs, publications and permanent files of many porcelain insulator manufacturers, both defunct and active.
- (2) Ceramic Company Directories, Electrical Manufacturer Directories and Product Guides of the American Ceramic Society, Thomas Register and other sources, various editions.
- (3) Interviews with owners and plant personnel of most of the active porcelain insulator manufacturers.
- (4) Inspection of plant sites and study of porcelain dumpage of most manufacturers (over 60), both defunct and active.
- (5) Reports of insulator styles and markings received from collectors reporting to the author as Porcelain Editor of Insulators, Crown Jewels of the Wire magazine.

BIBLIOGRAPHY

(Books on Porcelain Insulators)

- Brown, Gerald, Collectible Porcelain Insulators. Photos, sketches, catalog pages and general information on all forms of porcelain insulators and related items. Written for and used by collectors as a general reference on collectible types. Second Edition, 1972, softbound 8½" x 11", 176 pages, and Supplement, 1974, softbound, 8½" x 11", 74 pages, \$8.50 per set from the author, Box 1, Two Buttes, CO 81084.
- Kareofelas & Cranfill, Dictionary of Glass - Ceramic Insulators Reprint. Has reprints of selected pages from old insulator and poleline hardware catalogs. Illustrates many specialized porcelain insulators not pictured in other books, including this one. Softbound, 1977, 8½" x 11", 160 pp., \$4.75 from Gary Cranfill, 4010 Pennsylvania Ave, Fair Oaks, CA 95628.
- Mills, Brent, Porcelain Insulators and How They Grew. Detailed histories of U.S. manufacturers of high-voltage, wet-process insulators. Has no information on dry process insulators or manufacturers specializing in same. Hardbound, 1970, 6" x 9", 228 pp., \$10 from the author at 40 Wolcott St., LeRoy, NY 14482.
- Terrill, Frances M., Porcelain Insulators Photographed & Priced. Contains about 350 photos of porcelain insulators, primarily pin types, but essentially no researched information regarding them. Softbound, 1972, 5½" x 8½", 116 pp., \$3 from the author at 2356 N.W. Quimby St, Portland, OR 97210.
- Tod, Jack H., Porcelain Insulators Guide Book for Collectors. The most comprehensive reference on unipart pin type porcelain insulators, including both dry process and wet process. Evolution of insulator styles, Universal Style Chart with scale drawings of every known style manufactured (over 940), history of all manufacturers, every known marking on pin types, etc. The primary reference used by all insulator collectors. Second Edition, 1976, softbound, 8½" x 11", 160 pages, \$14.90 from the author at 3427 N. 47th Place, Phoenix, AZ 85018.

(Books on Glass Insulators)

- Milholland, Marion & Evelyn, Most About Glass Insulators. One of two primary reference books used by all collectors of glass insulators. Pictures every known glass pin type style and tabulates every known color and marking variety of each style (excluding some foreign) and other miscellaneous glass line insulators. Fourth Revision, 1976, hardbound, 6" x 9", 456 pp, \$15 from Evelyn Milholland, 145 E. 168th St., Spanway, WA 98387. (Annual collector price list available to match the book. Write author for information and price.)

Woodward, N. R., The Glass Insulator in America, 1973 Report. A primary reference book used by collectors of glass insulators. An original-research book with histories of the glass companies, the complete Consolidated Design Chart with scale drawings of all known styles of glass insulators. Softbound, 1973, 8½" x 11", 90 pp., \$4.85 from the author at P.O. Box 171, Houston, TX 77001.

Note: The abbreviated list of books above includes the ones researchers will find most useful for porcelain and glass insulators. Some of these books, plus several others, are also available from Frank Peters (books), 495 Carr Ave., Aromas, CA 95005. Some are postpaid, but others have some shipping charges, and some are higher priced if shipped out of the U.S. It is suggested you write for information before ordering.

(Periodicals)

Insulators, Crown Jewels of the Wire. The only nationally circulated magazine devoted exclusively to the insulator collecting hobby. Feature articles, research department, porcelain insulator column, letters, show reports, show calendar, classified ad section, etc. Each March issue is a name-and-address directory of all subscribers. Editor: Dora Harned, Rt. 1, Box 475, Chico, CA 95926. Porcelain Editor: Jack H. Tod. Softbound, 5½" x 8½", averages 52 to 64 pages monthly, \$7 per 12 issues. Order from the editor.

(Insulator Collector Organizations)

The National Insulator Association, founded in 1973, is the most important and largest insulator collector organization. It is active in numerous ways to advance the hobby for members and nonmembers alike. The "N.I.A." sponsors three large insulator shows annually, one in conjunction with its annual convention and the others in each of the other two geographic regions, and it sanctions local shows having worthwhile insulator activity. Major programs of unified member action in the N.I.A. include a Code of Ethics, uniform show floor rules, uniform exhibit and judging rules, insulator grading standards, a committee for the resolution of problems arising between members, and publication of material having general value to the membership.

The N.I.A. dues are very nominal, and the members invite all new collectors to join. For membership application, write (thru 1978) Paul Houpt, 211 S. Chauncey St., Columbia City, IN 46725. After 1978, write Dora Harned, Rt. 1, Box 475, Chico, CA 95926, or Jack H. Tod, 3427 N. 47th Place, Phoenix, AZ 85018.

There are numerous local and regional insulator clubs in the United States. Information regarding any club in your area may be obtained from the Executive Director of the N.I.A. on request (addresses above).

INDEX

A

Acme Porcelain Co.	69
Adamant Porcelain Co.	69
Adjustable knobs and cleats	54
Akron High-Potential Porc Co	101
Akron Insulator & Marble Co.	70
Akron Porcelain Co.	70
Akron Smoking Pipe Co.	70
American Insulator Co.	117, 169
American Knob Works	96
American Lava Corp.	117
American Porcelain Co.	71
Anderson Mfg Co (A & J M)	117, 168
Anderson Porcelain Co.	71, 83, 92
Angle-screw fixture	59

B

Bay Ridge Specialty Shop	72
Bergman Electric Co.	82
Bernard Co. E. G.	12
Boch (John) Porcelain Co.	72
Boch-Metsch Porcelain Co.	88
Break knob	61
Bridle ring insulators	58
Brunt (G.F.) Porc. Co.	73, 83, 92
Brunt Porcelain Co. (1920)	75
Brunt Tile & Porcelain Co.	75
Brunt & Thompson Porc. Co.	74
Buffinton & Dow	13, 14
Bushings, battery	51, 55
" , end outlet	56
" , hole	55, 156
Button, ceiling	51, 56

C

Cable rack insulator	60
Carey Ohio Porcelain Co.	75
"C. B. Knob"	59
Ceiling button	51, 56
Central Porcelain Co.	75
Ceramic Insulator Corp.	76
Ceramic Specialties Co.	69, 76
Chance Co. (A. B.)	76, 92
Cincinnati Porcelain Co.	76, 92
Circle F Mfg. Co.	77, 82
Clamp insulators	60, 150

Cleats, "B & D",	34, 42
" , evolution of	12
" , patented	28, 126
" , self-tying	137
" , standard	33, 42, 47
" , telephone	41, 48
Clevis, insulated	59
Colonial Sign & Insulator Co.	76
Cook Pottery Co.	77
Crossover insulators	49, 54, 141
Curran-Pfeiff Corp.	77
Current tap	57

D

Davidson Porcelain Co.	78
Davidson-Stevenson Porc. Co.	78
Diamond Porcelain Co.	78, 83, 92
Dixie Electrical Mfg. Co.	78
Downey Co. (Gilbert H.)	117
"Dry Process"	65
Dry-spot insulators	161
Duggan, Frederick A.	86
Duplex pin type insulators	161

E

Eagle Porcelain Co.	78
East End Pottery Co.	79, 97
East Liverpool Porc. Co.	79, 83
Efficiency Electric Co.	79
Electrical Porcelain Co.	79, 92
Electrical Porc. & Mfg. Co.	79
Electrose Mfg. Co.	117, 169
Embossed markings	66
Empire China Works	80, 99
"Emily Knob"	58
Eveready Porcelain Co.	78, 80

F

Federal Porcelain Co.	80, 92
Fence knobs	39, 53, 144
Fibre & composition insuls.	117
Findlay Electric Porcelain Co.	9
	81, 92, 169
Forestry insuls.	31, 41, 54, 153
Freeman (E H) Elec'tc Co.	82, 98
Freeman Porcelain Co.	77, 82, 98

G

General Electric Co.	74, 82
General Porcelain Co.	9, 71, 74 78, 79, 80, 83 89, 90, 92, 169
Glazing insulators	64
Globe Porcelain Co.	83
Greenwood Pottery Co.	84

H

Hall China Co.	85
Hartford Faience Co.	85

I

Illinois Electric Porc Co	86, 169
Imperial Porc. Works	13, 82, 86
Insulated clevis	59
Insulated fork	59

J

Johns-Manville, Inc.	117
Johns-Pratt Co.	117, 168, 169
Johnson China Co.	73

K

Kennelworth Tile Co.	87
Kiln firing of insulators	64
Kirchberger & Co., Inc.	87, 117
Knobs, electric fence	39, 53, 144
" , illustrated	29, 44
" , patented	130, 142
" , self-tying	14, 28, 53, 137
" , slack-wire	151
" , split	29, 30, 45, 46
" , standard	17-27, 35-39
" , telephone	41, 54
Knowles Co. (C.S.)	87, 169

L

Lightning arrestors, radio	58
Line Material Co.	86
Locke, Fred M.	80, 87
Louthan Mfg. Co.	71

M

Macallen Co.	117, 168
"Macomb" insulators	86
Manufacturers of wir'g devices	116
Manufacturing methods	63
Marking methods	66
Markings on insulators	103-115
McGraw-Edison Co.	86
Metsch Refractories, Inc.	88
Milligan (T.V.) Porcelain Co.	69
Mine insulators	154
Mogadore Insulator Co.	70, 88

N

Nail knobs, evolution of	13
" " , illustrations	53
National Ceramic Co.	88
National Electric Porc Co	89, 92
National Electric Code	15
National Insulator Association	177
National Porcelain Co.	89
New Haven Porcelain Co.	10, 89, 95
New Jersey Porcelain Co.	89
New Lexington High Volt. Porc.	100
Niagara Power Co.	6

O

Ohio Brass Co.	101, 117, 168
Ohio Porcelain Co.	9, 83, 90, 92

P

Parker & Son Co. (J.H.)	8, 169
Pass & Seymour, Inc.	90, 169
Patents:	
Design patents	123
First-number-of-year table	171
General information	119-124
How to order patents	124
Illustrated patents	126-156
Letters patents	123
Official Gazette (O.G.)	123
Patent Office	123
Reissue patents	123
Search procedures	124
Tod Classifications	125
"Tuesdays" table	170
"Class 174" patents	124, 172
Peach Porcelain Co.	69, 90

